

STRUCTURAL BUILDING COMPONENTS™

THE FUTURE OF FRAMING

May 2014

www.sbcmag.info

Seismic Design Coefficients

How they are determined for light-frame components

Plus: Heel Height Load Paths
Short-Term Solution for
Increased Production
Production Training
...and much more!

CHANGE SERVICE REQUESTED

SBC Magazine • 6300 Enterprise Lane • Suite 200 • Madison, WI 53719

PRRS STD
U.S. Postage
PAID
Madison, WI
Permit No. 2223

Framing the
AMERICAN
DREAM®

KNOW WHERE EVERY ORDER STANDS. **EVEN ON THE MOVE.**

When building custom homes, there's no such thing as business as usual. Stay on top of each quote and order when you're in the field with MBA™ Mobile. Get instant access to prices, schedules, delivery tickets, layouts, engineering data and even live directions to the jobsite. Find out where MBA™ Mobile can take your business at MiTek-US.com/MBAmobile.



MBA™ MOBILE

Available on any browser-enabled device.

© 2014 MiTek, All Rights Reserved.



Better Technology. Better Building.™

Publisher

Truss Publications, Inc.
6300 Enterprise Lane • Suite 200
Madison, WI 53719
Phone: 608-310-6706 • Fax: 608-271-7006
trusspubs@sbcmag.info • www.sbcmag.info

Editor

Scott Ward
Southern Components, Inc. • editor@sbcmag.info

Managing Editor

Sean Shields
608-310-6728 • sshields@sbcmag.info

Art Director

Melinda Caldwell
608-310-6729 • mcaldwell@sbcmag.info

Editorial Review

Kirk Grundahl
608-274-2345 • kgrundahl@sbcmag.info

Suzi Grundahl
608-310-6710 • sgrundahl@sbcmag.info

Advertising Sales & Marketing

Melinda Caldwell
608-310-6729 • mcaldwell@sbcmag.info

Sean Shields
608-310-6728 • sshields@sbcmag.info

Staff Writers for May

Dan Hawk, E.I.T. •
Daniel Lawless, MSCE, Structures

Accountant

Mike Younglove
608-310-6714 • myounglove@sbcmag.info

Computer Systems Administrator

Jay Edgar
608-310-6712 • jedgar@sbcmag.info

**Send all ad materials, insertion orders,
contracts & payments to:**

Truss Publications, Inc.
6300 Enterprise Lane • Suite 200
Madison, WI 53719
Phone: 608-310-6706 • Fax: 608-271-7006
trusspubs@sbcmag.info • www.sbcmag.info

contents

Page 16



Manual Labor

A Short-Term Solution to Increase Production

by Sean D. Shields

Page 18

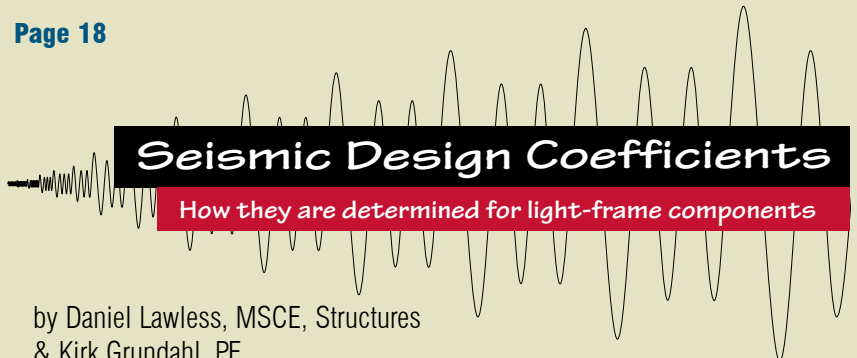

Seismic Design Coefficients

How they are determined for light-frame components

by Daniel Lawless, MSCE, Structures
& Kirk Grundahl, P.E.

on the cover:

Cyclic test of 12' x 30' building with OSB shear walls

Page 24

TOP 10 Employee Training Tools

Production Training by Ben Hershey & Sean D. Shields

Editor's Message	5
Framers Council	8
Technical Q&A	10
Parting Shots	26

The mission of *Structural Building Components Magazine (SBC)* is to increase the knowledge of and to promote the common interests of those engaged in manufacturing and distributing structural building components. Further, *SBC* strives to ensure growth, continuity and increased professionalism in our industry, and to be the information conduit by staying abreast of leading-edge issues. *SBC's* editorial focus is geared toward the entire structural building component industry, which includes the membership of the Structural Building Components Association (SBCA). The opinions expressed in *SBC* are those of the authors and those quoted, and are not necessarily the opinions of Truss Publications or SBCA.



Tested.

EAGLE
METAL



Conconnector plates represent the heart of any truss manufacturing plant. As a supplier of structural connector plates to manufacturers across the country, Eagle Metal is the name to count on when the heart of your business is on the line.

Engineered. Tested. True.®

www.eaglemetal.com • 1-800-521-3245



editor's message

by Scott Ward

Growth Is Good

SBC is a valuable tool; read it, use it, contribute to it and help it continue to grow.

You may or may not have noticed that in January, **SBC Magazine** expanded from 24 to 28 pages. That's pretty darn exciting, because it is representative of our industry's growth. Not contraction. Not survival. Positive growth. What a breath of fresh air.

This magazine's growth is thanks directly to the commitment of our industry's suppliers. Our Gold Advertisers stuck with us through thick and thin and put cold, hard cash on the table to ensure this publication survived during the lean years. My hat is off to them, and I would encourage all of you to thank the ones you do business with (a list on our website at sbcmag.info/advertisers).

In 2014, we are witnessing the return of past loyal advertisers who helped build **SBC** into the 128-page encyclopedia it was in its heyday. While it's unlikely we will ever get back to printing so many pages, expanding to 28 means that a lot more valuable content can be communicated to you and the marketplace each month. I believe it's vital we all reach out to our suppliers and encourage them to consider advertising in our magazine. It will increase their exposure (while publicly showing their support for our industry), it will improve their sales, and it will bolster this important tool for promoting our industry.

As we look to add more content to the magazine, it's important to reflect on what we put in these pages and why we put it there. **SBC's** mission is to increase the knowledge of and to promote the common interests of those engaged in manufacturing and distributing structural building components. Further, it strives to ensure growth, continuity and increased professionalism in our industry, and to be the information conduit by staying abreast of leading-edge issues.

If you want to know what's going on in our industry, what the next trend is, or what is the latest thing threatening our market share, **SBC** is the place to go first to find out. It's a powerful business tool that helps ensure we don't operate in a vacuum, but have the ability to make informed decisions based on solid information. These pages help us remember our past, embrace our current success and, ultimately, explore our opportunities for the future.

at a glance

- This year, **SBC** expanded from 24 to 28 pages, thanks to the commitment of our industry's suppliers who advertise in the magazine.
- Be sure to check out the weekly email newsletter, **SBC Industry News**, which offers insight into general industry news and trends involving CMs, suppliers and the economy.
- If you find yourself doing something a bit differently, or you complete a project you're particularly proud of, let **SBC** staff know so they can share it with the industry.

Over the past few years, **SBC Magazine** branched out into electronic media with a new website (sbcmag.info) and a weekly email newsletter, **SBC Industry News Top Headlines**. **SBC Industry News** is intended to offer insight into general industry news and trends involving component manufacturers, suppliers and the economy. Based on its wide weekly readership, it evidently provides a good cross section of our industry a greater depth of industry knowledge, an enhanced ability to benchmark performance, an aid in strategic planning, and a spotlight for innovation. If a supplier or fellow manufacturer comes up with a new way of doing things that will make me more profitable, I want to know about it. **SBC Industry News** is a good tool to do just that. If you aren't taking the time to look at the headlines when the email shows up in your inbox, you should seriously reconsider.

The interesting thing about **SBC Industry News** is that, unlike **SBC Magazine**, the content comes from a wide variety of news sources across the country. Sometimes

Continued on page 6

Share with SBC staff your stories and perspectives, and encourage suppliers to support of our industry by helping this magazine continue to provide great content.

Editor's Message

Continued from page 5

the news on the web is favorable to our industry and the companies that make it up; sometimes it's not so good. Sometimes the news articles out there are well written and factual; other times, an author's bias is overly evident. Through it all, these headlines help inform each of us on what our marketplace is being told or what it may believe.

Speaking of being told, **SBC Magazine** and **SBC Industry News** are a great opportunity for component manufacturers and suppliers to highlight the innovative things they are doing. During this upcoming build season, if you find yourself doing something a bit differently, or you complete a project you're particularly proud of, let **SBC** staff know so they can share it with the industry. If you read something in **SBC Industry News** and know more about the topic or the situation, let **SBC** staff know, or comment on the story online and help enlighten the whole industry.

I would be remiss without mentioning that **SBC** also supports an important endeavor for our industry, the annual **SBC** Legislative Conference in Washington, DC. As you read these pages, a group of us are storming Capitol Hill and talking with our members of Congress about public policy issues impacting our industry, from the lack of skilled labor to disastrous reforms proposed for the federal housing finance system. We will tell you how it all turned out in the next issue of **SBC**.

Growth is great (it sure beats the alternative). Help **SBC** continue to grow and add value to your business. Share with **SBC** staff your stories and perspectives, and encourage suppliers to support of our industry by helping this magazine continue to provide great content. **SBC**

SBC Magazine encourages the participation of its readers in developing content for future issues. Do you have an article idea for an upcoming issue or a topic that you would like to see covered? Email your thoughts and ideas to editor@sbcmag.info.



STANDING STRONG

GEARING UP FOR GROWTH

BCMC
bcmcshow.com

Register Now!

**October 7 - 10
Charlotte, NC**



SBCA Board of Directors

Officers & Executive Committee Reps.

- **President: Scott Ward** • Southern Components, Inc.
318-687-3330 x106
- **President-Elect/Treasurer: Richard P. Parrino**
Plum Building Systems, LLC • 515-978-6260
- **Secretary: Jess Lohse** • Rocky Mountain Truss Co.
406-265-5140
- **Past President: Steve Stroder** • Timberland Lumber Co.
317-339-7585
- **Kenneth M. Cloyd** • California TrusFrame
951-657-7491
- **Barry Dixon** • True House, Inc.
904-757-7500
- **Dwight Hikel** • Shelter Systems Limited
410-876-3900
- **Joseph D. Hikel** • Shelter Systems Limited
410-876-3900

At-Large Representatives

- **Greg Griggs** • ProBuild Southeast • 770-428-2604
- **Don Groom** • Panel Truss Texas, Inc. • 903-657-7000
- **Kendall Hoyd** • Trussway Holdings, Inc • 713-590-8811

Directors Representing Chapters

- **Keith Azlin** • U.S. Components, LLC • 520-882-3709
- **Michael Balliet** • Builders FirstSource/Bama Truss & Components •
205-669-4188
- **Rick Cashman** • Florida Forest Products • 727-585-2067 x307
- **Jack Dermer** • American Truss Systems, Inc. • 281-442-4584
- **Issam Fakhoury** • Allwood Building Components • 586-727-2731
- **James C. Finkenhoefer** • Truss Systems, Inc. • 770-787-8715
- **Taft Ketchum** • PDJ Components, Inc. • 845-469-9191
- **David Motter, P.E.** • Louws Truss, Inc. • 360-384-9000
- **David A. Raasch** • Lloyd Truss Systems • 507-387-4250
- **Michael L. Ruede** • A-1 Roof Trusses • 772-409-1010
- **Steven Spradlin** • Capital Structures, Inc. • 479-783-8666
- **Javan Yoder** • Stark Truss Company, Inc. • 330-478-2100 x2223

Associate Member Directors

- **David B. Brakeman, P.E.** • ITW Building Components Group •
314-344-9121



Solid Performance Shear Versatility

Introducing the newest addition to our shearwall family – the Strong-Wall® SB shearwall. It combines **performance** – high load values – with **versatility** – it's trimmable in the field. The SB wood prefabricated shearwall is an economical solution for many applications, including narrow and tall wall spaces and garage portals. It's available in three widths and heights up to 20' that can be conveniently trimmed to fit your job and eliminate shimming.

For a high-performance, versatile and economical wall, try the Strong-Wall SB shearwall. Learn more by calling your local rep at 800-999-5099 or visiting strongtie.com/sb.

SIMPSON
Strong-Tie

®



Engineering, Knowledge & Building Relationships

Testing can lead to better engineering, which will lead to more efficient framing.

Engineering and testing can improve labor efficiencies in the framing industry, as well as greatly impact the business of building wood structures. In today's optimized world, we need to manage projects efficiently in order to make a profit. Labor is often the largest cost on a project. By approaching engineering and testing through the eyes of framers, NFC can make the framing process more reliable and cost effective. We can work with engineers to develop framer-friendly industry details, critique and question industry performance standards, and continually test the raw material and conventional systems with which we work. As NFC develops good relationships with engineers, framers can get more input in the building process from the beginning and share our expertise to improve framing reliability, accuracy, efficiency and safety.



Full-scale assembly set-up tested at SBCRI.

In the design of wood structures, engineering is of the utmost importance. Determining proper loading and load paths is critical for the structure to resist loads as intended. Engineers attempt to maximize the efficiency of wood structures through optimizing the design of components, and getting input from component manufacturers and framers is essential in this process. By developing industry standard details and standardized approaches to assembling the various parts and pieces that go into a building, framing consistency will increase framers' speed and reliability. Working directly with framers to develop these standardized approaches, engineers will get direct input from the field and be better able to optimize the connections and associated assembly details. NFC will help framers accomplish this by working directly with the engineers on staff at the Structural Building Components Association (SBCA) who are committed to creating draft details that will form the basis of our work on standardized approaches to assemblies.

at a glance

- By approaching engineering and testing through the eyes of framers, NFC can make the framing process more reliable and cost effective.
- SBCRI is fully capable of testing any type of full-scale assembly, which can provide framing contractors great insight into the performance of the products they use on a daily basis.
- Testing raw materials, products and structural systems will ensure that framers understand real performance and derive maximum value from the product or engineered solution.

Testing through the SBC Research Institute (SBCRI) will be critical in this process. I've had the pleasure of touring this impressive testing facility in Madison, WI. SBCRI is capable of testing any type of full-scale assembly, which can provide framing contractors great insight into the performance of the products they use on a daily basis. This has great potential benefits to our NFC work, given that sound knowledge will lead to great training and the optimal industry best practices.

Framers also need to work closely with the engineering community to question standards and any implementation feasibility and downside risks they may pose. For example, OSHA standard 1926.502 (d)(15) states:

Anchorage used for attachment of personal fall arrest equipment shall be independent of any anchorage being used to support or suspend platforms and capable of supporting at least 5,000 pounds (22.2 kN) per employee attached or shall be designed, installed, and used as follows:

- as part of a complete personal fall arrest system which maintains a safety factor of at least two; and
- under the supervision of a qualified person.

In my experience, finding an anchorage point that can sustain 5,000 pounds can be



Add your voice to NFC. Join Now!
 Download an application at
framerscouncil.org

a big challenge, especially in the beginning of a project when the first joists and/or trusses are being installed. Fall protection is critical for framer safety, and there needs to be an easier way to achieve a suitable anchorage point. SBCRI can provide testing for NFC to determine if the 5,000-pound federal requirement is truly feasible and/or required to adequately arrest a falling individual. Based on preliminary testing that SBCRI has undertaken with the National Institute of Occupational Safety and Health (NIOSH), there is a great opportunity to provide far better knowledge in this area of the OSHA standard. This can lead to development of a wide variety of anchorage devices and systems that can be a part of a complete personal fall arrest system that has a true safety factor of two and also can be easily used by framers.

Working closely with SBCRI, NFC will ensure that our needs are directly communicated to engineers, and we can work together to achieve a simple, concise and realistic solution. With efficient anchorage points and time-and-motion studies, framers will reduce labor costs associated with implementing some of the more convoluted fall protection systems today, while increasing framer safety on the jobsite, reducing the chance of an injury, and promoting a healthy workforce.

Lastly, working with engineers to test structural systems and raw materials ensures that framers get maximum value from raw materials. Assemblies of components act much differently than individual components. Other than some of the work SBCRI has performed, limited testing has been done to identify the benefits of components acting as a system, and little of this testing that we are aware of has had direct involvement by the framing community. We know that we need to test to ensure that we fully understand the available strength of all the raw materials that we use. It is essential to our best practices to know if lumber grades are accurate and consistent, for instance. The downgrade of Southern Pine was a shock to the industry, not only because the design properties were downgraded, but because of the extent to which they were downgraded. Likewise, it was a shock that an industry as large as the lumber industry would not automatically provide consistently great material to assure framing reliability. When changes in lumber properties do occur, depending on the extent, the building owner may determine the need to reinforce or replace certain parts of the structure. This increases labor costs associated with the project. Consistent testing by each lumber manufacturer to verify stated properties ensures that, when downgrades do occur, they are less severe. Testing is critical to ensure that good value and material usage is maximized. Consistent lumber grades and strength values provide consistent performance and confidence.

Framers stand to benefit from building good relationships with engineers. Reducing labor costs by even a small amount on every project can add up. As a professional framer and member of NFC, I am encouraged by the potential for more communication between engineers and framers and how that can improve the entire industry. By working with engineers and providing input starting with the design phase, we can reduce labor costs associated with the design, detailing and framing process, thereby increasing framing reliability, speed and accuracy for all. **SBC**

George Hull is President of Hull Associates, LLC in Arlington, TX. He brings more than 35 years of framing experience as the first Chairman of the National Framers Council. For more information about NFC, visit framerscouncil.org.

WASSERMAN & ASSOCIATES

proudly represents the following manufacturers:

Monet DeSaw
 MangoTech
 WoodRunner
 Square 1
 Wizard
 Precision Equipment
 The Hain Company
 Builders Automation



WASSERMAN & ASSOCIATES, INC.

For more information, call us at
800-382-0329 or visit our new
 user-friendly, mobile device
 compatible website at

wasserman-associates.com



Precision Equipment MFG delivers premier truss trailers specifically designed to accommodate the challenging demands of the building industry. Precision Equipment MFG offers multiple truss trailer sizes in the gooseneck, standard and extendables. Precision Equipment MFG incorporates industry leading manufacturing components and features to ensure an excellent return on your investment.

Toll Free: 800.237.5161

Phone: 701.237.5161

sales@precisionequipmentmfg.com
www.precisionequipmentmfg.com



Isolated Testing Helps Understanding of Heel Height Load Paths: Downstream Improvements Probable

Further testing could yield a better understanding of heel blocking requirements under differing load conditions.

Question

More frequently, blocking is required for installation of high heel trusses, when no such requirement existed in the past. What is going on, and has any work been done to define and improve this concept?

Answer

The 2009 International Residential Code (IRC) introduced blocking requirements to transfer the lateral load resulting from wind and seismic events into braced wall lines. The 2012 IRC further clarified these requirements to provide more guidance.

As more and more municipalities adopt the 2009 and 2012 language, this will likely become an even more common issue where help with implementation is needed. Couple the IRC requirements with energy code requirements that are pushing more buildings to utilize a higher heel, and it is apparent the connection of high heels to walls is a key application issue.

SEISMIC DESIGN CATEGORY AND WIND SPEED	DISTANCE (bottom of roof sheathing to top of top plate) (See Figure R602.10.8.2)	BLOCKING*
SDC A, B, C and wind speed less than 100 mph	9.25" or less	Not required per Section R602.10.8.2, Item 1. Roof framing attached per Section R602.3(1)
	Greater than 9.25" to 15.25"	Required per Section R602.10.8.2, Item 1 and Figure R602.10.8.2(1)
SDC D ₀ , D ₁ , D ₂ or wind speed 100 mph or greater	15.25" or less	Required per Section R602.10.8.2, Item 2 and Figure R602.10.8.2(1)
All SDCs and wind speeds	15.25" to 48"	Required per Section R602.10.8.2(2) or Item 3 or Figures R602.10.8.2(2) or R602.10.8.2(3)

For SI: 1 inch = 25.4 mm, 1 mile per hour = 0.45 m/s.
a. Rafter or truss connection to top plate per Table R602.3(1).

Figure 1. 2012 IRC Table R602.10.8.2.

2012 IRC Table R602.10.8.2 outlines the requirements for when blocking is required, and is a function of the seismic design category, the design wind speed, and the height of the heel (see Figure 1).

at a glance

- Couple the IRC requirements with energy code requirements that are pushing more buildings to utilize a higher heel, and it is apparent the connection of high heels to walls is a key application issue.
- The SBC Industry Testing Task Group and the TPI TAC/SBCA E&T Testing Review and Vetting Group has begun to evaluate the needs and priority of testing the performance of assemblies to quantify the effect of heel blocking.
- It is clear from the very specific and isolated heel height testing already performed that there is an opportunity to provide revisions to 2009 and 2012 model code blocking requirements to transfer the lateral load resulting from wind and seismic events into braced wall lines.

Connection & Blocking Requirements Between Braced Wall Panels and Roof Framing

Trusses in seismic design categories A, B, C with wind speed less than 100 mph and heel heights of 9-1/4" or less will not require any additional attachment, while trusses in the same seismic and wind categories with a heel height greater than 9-1/4" but less than 15-1/4" will require blocking as shown in Figure 2. Trusses, of any heel height 15-1/4" or less, in seismic design category D₀, D₁, D₂, or wind speed 100 mph or greater, will also require blocking as shown in Figure 2. All trusses, in any seismic or wind area, with a heel height greater than 15-1/4" will require blocking as shown in Figure 3.

Heel height blocking requirements are becoming a common enough issue that the SBC Industry Testing Task Group and the TPI TAC/SBCA E&T Testing Review and Vetting Group has begun to evaluate the needs and priority of testing the performance of assemblies to quantify the effect of heel blocking. Most people within the industry believe the new requirements are excessive and would like to understand the true impact of blocking. The codes and the more traditional engineers always try to simplify problems like this, which generally leads to very conservative results because the simplifying assumptions have to be so general in nature. Testing always helps with understanding of how the load paths operate and makes more precise resistance easier to implement. Some of the key issues that need to be addressed include:

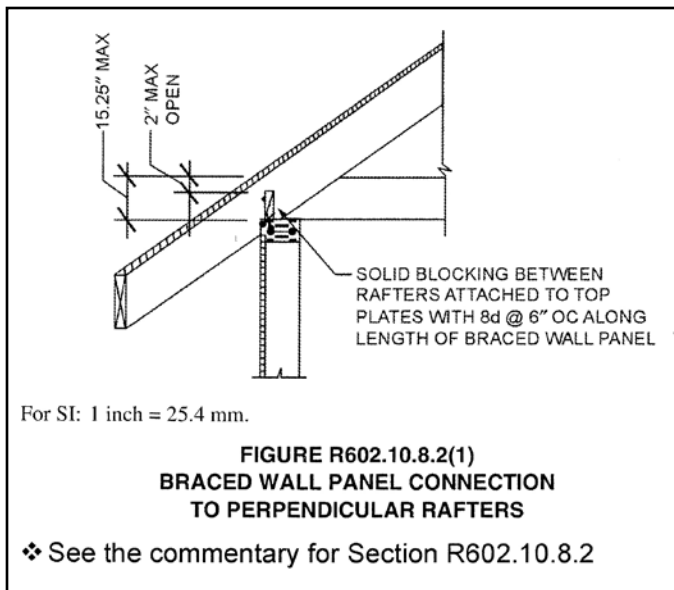

Figure 2. 2012 IRC Figure R602.10.8.2(1).

1. How do the trusses, when attached to a diaphragm and properly braced, rotate to produce a lateral load?
2. Is the truss roof or floor diaphragm really a flexible diaphragm?
3. Is the truss roof or floor diaphragm more rigid than we think, and how does that semi-rigidity affect the load transfer of the diaphragm onto the plate of the wall system below?
4. Is the roof diaphragm more rigid than the wall, and if so, when does the wall fail?
5. Is this really a shear wall design problem and not a roof diaphragm issue?
6. What about the code-compliant connections of the truss to wall interface?
7. How do the connection systems perform?
8. Do *IRC* connections work?

While there is still much to consider with regard to a testing plan and a timeline for carrying out such testing, it has potential to provide valuable information to the industry with respect to ensuring the code requirements more accurately, yet still reliably, represent the actual load paths that exist.

In the meantime, some testing has already been completed by the USDA Forest Service, which has shown the *IRC* prescriptive requirements to be conservative in certain applications. The study and general technical report (FPL-GTR-214)¹ examined the performance of nine different five-truss assemblies, as summarized in Table 1. Load was applied to the system at the center vertical web of the truss

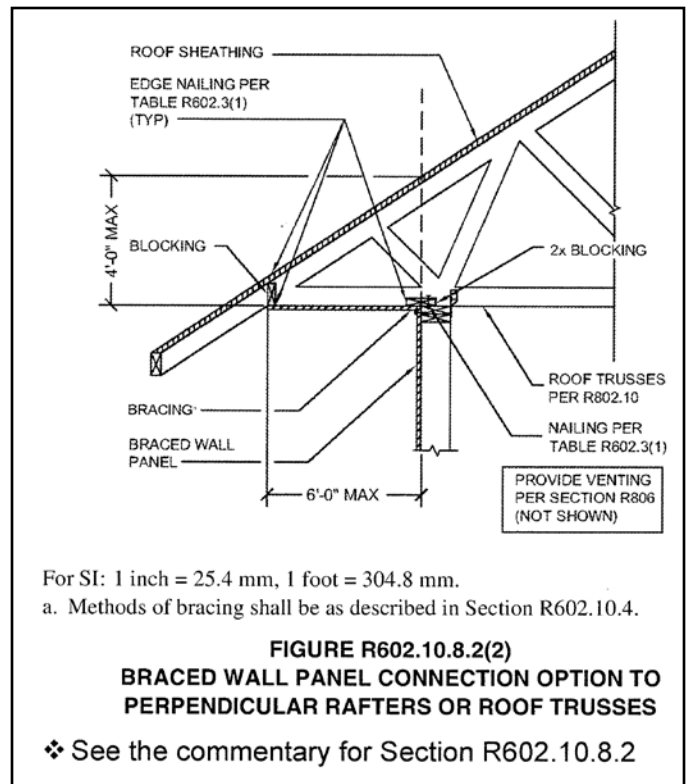

Figure 3. 2012 IRC Figure R602.10.8.2(2).

Config. Name	Heel Height	Roof Slope	Blocking Type
A	91/4"	7/12	No Blocking
B	151/4"	7/12	No Blocking
C	151/4"	3/12	No Blocking
D	151/4"	7/12	OSB Sheathing on Truss Heel
E	151/4"	7/12	OSB Sheathing on Truss Heel Extended over Wall Top Plate
F	151/4"	7/12	25% Partial Height Blocking
G	151/4"	7/12	50% Partial Height Blocking
H	151/4"	7/12	Diagonal Bracing on Truss Webs
I	151/4"	7/12	OSB Sheathing on Truss Heel Extended over Wall Top Plate with Reinforced Ceiling Diaphragm

Table 1. Tested Configurations compiled from FPL-GTR-214 (see pages 6-9 of FPL document).¹

assembly in a manner to create the highest eccentricity at the heels. The intent was to have results applicable to as many different scenarios as possible. The ultimate load performance for each configuration, as well as its performance relative to configuration "A," is provided in Table 2 on page 12.

Continued on page 12

¹ www.fpl.fs.fed.us/documnts/fplgtr/fpl_gtr214.pdf

Config. Name	Ultimate Load (lb)	Change in Ultimate Compared to "A" (%)
A	5,140	-
B	3,525	-31%
C	3,780	-26%
D	4,344	-15%
E	4,755	-7%
F	3,988	-22%
G	4,520	-12%
H	3,633	-29%
I	6,794	32%

Table 2. Ultimate Load Summary.

Technical Q&A

Continued from page 11

As can be seen in Table 2, there is an effect caused by the high heel, which does in fact reduce capacity. Concerns over the decrease in capacity, however, should be mitigated by the fact that, as stated in the FPL report, "Analysis presented in Table 6 shows that all tested specimens, including the benchmark specimens without eave blocking, exhibited sig-

nificant strength capacity over design wind loads in both 90- and 110-mi/h wind zones, with factors of safety ranging from 3.1 for the unblocked high-heel specimen up to 6.0 for the OSB-braced specimen with a reinforced ceiling diaphragm."

The results of this study indicate that use of OSB sheathing on heel heights up to 15-1/4" should provide adequate resistance for the vast majority of seismic categories and wind speed without the requirement of additional blocking.

Additional Thoughts

It is clear from the very specific and isolated heel height testing performed that there is an opportunity to provide revisions that take advantage of this knowledge. SBCA staff will explore whether this is possible, given this

test information. In addition, SBCA staff will make recommendations on how to integrate the testing with current engineering mechanics, based on generally accepted engineering practice, where we can define a few details that provide more efficient load transfer solutions when trusses are used. Beyond this, the key issues defined in this article provide fertile ground for test-based improvements in load path understanding and even more accurate load transfer details. **SBC**

To pose a question for this column, email technicalqa@sbcmag.info.



Machinery. Parts. Service.

- ✓ **New, state-of-the-art** component manufacturing & material handling systems – by the industry leaders.
- ✓ **Used & Reconditioned** machinery. Eide's warranty on reconditioned equipment meets or exceeds the new machine warranty.
- ✓ **Installation & Operator Training** included or available with any equipment purchase.
- ✓ **Table Retrofit** and upgrades for WizardPDS®.
- ✓ **Parts & Supplies.** Our parts department stocks thousands of parts & supplies for most brands of cutting and pressing systems. Custom and obsolete parts fabrication is our specialty.
- ✓ **Service & Repair.** Our service department offers complete repair, rebuilding and retro-fit services; in-house or on-site.
- ✓ **Equipment moving,** installation, and operator training services.
- ✓ **Auction Buyers Service;** We remove, ship and reinstall your equipment.
- ✓ **Overseas Buyers;** We can service and update your purchase as desired, containerize, ship and re-install the machine in your plant.

We know machinery.



Machinery ~ Supplies
~Since 1927~



eidemachinery.com

Toll free 800-344-EIDE | Eide Machinery Sales, Inc. | PO Box 11397 / 3219 North Second Street Minneapolis, MN 55411-0397

Load.

Squeeze.

Cut.

Profit.

Your 4-STEP Program To RECOVERY

Selecute®



THE HOLTEC SELECUTE® V-SERIES WITH INLINE SQUEEZE

Step 1
Load
Lumber



Step 2
Squeeze
Lumber



Step 3
Cut
Lumber



Step 4

PROFIT

In today's economy, finding the reliable path to profits is a challenge. But with the help of a HOLTEC, you can cut costs, squeeze every dollar, and get on the road to *real* recovery and profit.

We know that maximum efficiency, speed and accuracy are the nuts and bolts of our industry. Only the HOLTEC V-Series systems deliver them all, along with a bankable reduction in labor costs. With precision German engineering that ensures unmatched speed, and accuracy of +/-1mm (.040")* on every cut, you'll never miss a deadline or fail to deliver on your customers' demands.

Our systems are designed to make the impossible seem effortless. They keep your workflow merging smoothly into a bigger profit margin so you'll stay ahead of the competition and the market.

Supported by our experienced, Florida-based team, we offer an on-time delivery and service guarantee that's an industry legend, and assures that our customers can **always** deliver on their commitments.

These innovations are among the priceless reasons HOLTEC remains the system of choice for over 8,000 systems worldwide, over 1,700 HOLTEC systems in operation here in North America.

Visit us on the web at holtecusa.com, email us at info@holtecusa.com, or call us at 1-800-346-5832.

Discover how a HOLTEC system can put you on the personal road to recovery, with profit that's sustainable in every kind of market condition.

1-800-346-5832

www.holtecusa.com

HOLTEC®

PRECISION CROSSCUT SYSTEMS

Holtec (USA) Corporation, 2802 Sydney Road, Plant City, Florida 33566

Tel.: [813] 754-1665 Fax: [813] 752-8042

Email: info@holtecusa.com

*All specifications and prices are subject to change without notice. Photographs may show systems with optional accessories. Stroke speed may vary based on specie and dimension of lumber. Proper maintenance is essential for accuracy and longevity. HOLTEC, AUTOCUT, SELECUTE and TRANSCUT are registered trademarks of HOLTEC GmbH. All other trademarks are the property of their respective owners. Price is F.O.B. Tampa, Florida. © HOLTEC (U.S.A.) Corporation. All rights reserved.



MJI[®]
MiTek[®]

Better Technology. Better BuildingSM



YOU BUILD STRUCTURAL COMPONENTS. WE BUILD SUPPORT.

We're known for tools and technology. From advancements in structural connectors and fasteners to automated equipment and software, we're streamlining the component production process.

You're known for being the leaders in the markets you serve. And so our technology alone doesn't define us. We put our industry-leading experience, expertise and passion into every relationship we serve. Because our true business is helping you succeed.

Explore our commitment to you:

Contact your MiTek Manager or visit MiTek-US.com/LeaderSupport.



Photo courtesy of Jay Halteman

Manual Labor

A Short-Term Solution to Increase Production

by Sean D. Shields

All three of these experts agreed on the bottom line: pull out and dust off all of your owner's manuals. Make sure everyone running each piece of equipment is made aware through on-the-job training of the insights found on those pages.

This past winter was like a bad party guest. It arrived early, was loud and obnoxious, and stayed long past its welcome. Spring has finally pushed it out the door, which means all of those housing permits are finally turning into housing starts in all parts of the country. Everyone is ramping up production, but in many markets, additional labor is hard to find and new equipment is difficult to get in a timely manner.

All hope is not lost—three production equipment experts agree there is a simple solution for component manufacturers that doesn't require additional labor, can be implemented quickly, and is relatively inexpensive. The solution: assess your current equipment by starting with a review of your owner's manuals.

The Labor Problem

"For many manufacturers that survived the downturn through wise operational decisions, it's reasonable they expect this is the time they reap the benefits of their good stewardship," said Rod Wasserman, General Manager of Wasserman & Associates. "Unfortunately, many can't find the labor they believe they need to ramp up production."

"Back in the first half of the 2000s, it was easy to throw employees at the problem of increased capacity," echoed Jay Halteman, President of Wood Truss Systems, Inc. "Not only will that not work in today's market, but most manufacturers who survived the past seven years had to learn lean lessons and do more with less people on the payroll."

Indeed, the human factor is a difficult challenge. Not only are viable workers resource-intensive to find, hire and train, they also require a great deal of constant effort to keep happy, safe and productive. But don't misunderstand, employees are your most valuable asset. In the end, your various pieces of equipment are just tools that ultimately rely on the expertise of their operators to efficiently churn out high-quality products.

The point is that the days of throwing more employees at your production problems are gone; it's time to throw *better-informed* employees at those problems.

The Current Equipment Problem

When it comes to your production equipment, component manufacturers likely face one or more of the following problems: one, due to turnover, they have less experienced employees running their equipment who have not been fully trained on its operational capacity; two, newer employees are still learning how to conduct thorough equipment maintenance; and three, due to the economic downturn, equipment is running on outdated software and/or computer hardware.

"There is always a learning curve with equipment," said Wasserman. "Unfortunately, when you go through the personnel attrition our industry did, there is an inevitable knowledge loss that happens." It's easy to see how this could happen, even moreso through the prolonged nature of the downturn.

Most manufacturers went through significant stretches where they didn't have to rely on their equipment to run at peak efficiency and capacity. Many equipment functions weren't necessary to utilize and were either abandoned or forgotten over time. As new employees came on board, it's likely they weren't told of those capabilities when they were trained by their supervisors.

"Most of the individuals running your typical component saw or gantry table today were instructed by a supervisor when they were hired," said Halteman. "As a result, they just don't know the full capabilities of the equipment they run on a daily basis. I see it all across the country."

Not only is the equipment not running at peak capacity, but proper preventative maintenance is likely not being done to its fullest extent either. "It's just like owning a car; you need to regularly assess all the moving parts and repair or replace those that get worn down and reapply lubrication where needed," said Halteman. "Preventative maintenance will cost you \$200 here and there, but if you don't take care of something before it seizes up, you can face repair costs of over \$6,000, plus the lost production time."

Finally, your production equipment is highly sophisticated, even if it's 20 years old. "Equipment manufacturers are constantly updating the software used to run it, in response to the changing efficiency needs of their customers," said Steve Shrader, Sales Manager for Hundegger USA, L.C. "In some cases, that software requires newer computer hardware to run correctly."

When assessing your computer software and hardware, Shrader advises casting a larger net. "It's important to have a handle on all your fundamentals, like electricity, Internet connectivity, compressed air, etc. The weak link in the interconnected system that runs your equipment is what ultimately will hold you back."

All three of these experts agreed on the bottom line: pull out and dust off all of your owner's manuals. Make sure everyone running each piece of equipment is made aware through on-the-job training of the insights found on those pages. "Pay particular attention to the safety features of the equipment and the preventative maintenance opportunities that may not be currently followed," said Halteman. "Once you're done with the manuals, consult with the manufacturers; they are a great resource for additional training."

The Future Equipment Problem

So why bother with re-evaluating old equipment, going through the trouble of reading dusty manuals, and retraining staff when new equipment holds such promise for greater through-put? The reality is that new equipment, beyond being a significant financial investment, currently takes a long time to bring on line.

"Lead times for state-of-the-art equipment is very far in the future at the moment," said Wasserman. He's quick to point out that equipment manufacturers went through the same struggles component manufacturers did during the downturn. "Once everyone stopped buying equipment in 2006, they had to lay people off and significantly scale back production. Since 2007, very little new equipment has been manufactured."

The glut of used equipment that flooded the market as component manufacturers went out of business added to the problem. Both Wasserman and Halteman agreed it wasn't until a little over 18 months ago that equipment makers finally saw an opportunity to sell new equipment again.

"The new equipment today holds incredible potential for increased production and quality, so it makes good sense to begin evaluating now where you want to be in the future and what kind of equipment you will need to get there," said Shrader. "But it's not going to solve the production capacity problems you are facing right this moment."

Okay, so if brand new equipment can't be an immediate answer, what about used equipment? "That market has dried up, and good used equipment is very scarce," said Wasserman. "We used to have over 400 pieces of good equipment highlighted on our website. Today, we have less than 125."

Conclusion

After assessing your current equipment, you may find that new equipment is the answer to your long-term needs. In future issues of **SBC Magazine**, we will talk with equipment manufacturers about their guidance on how to assess the current technology and find the best fit for your operations. In the meantime, the experts agree that your best short-term solution is to break out your manuals, contact your equipment vendor, and start training your employees on how to take full advantage of the equipment you currently have. **SBC**



Figure 1. Cyclic test of alternative shear resisting wall element.

Seismic Design Coefficients

How they are determined for light-frame components

by Daniel Lawless, MSCE, Structures & Kirk Grundahl, PE.

Why Seismic Design Coefficients (i.e., Factors) Are Important to Engineering Innovation

As component manufacturers (CMs), our industry is usually not involved in the structural design of wall panels. However, with the recent changes in the energy codes, more and more customers of CMs are looking for ways to enhance the energy efficiency of their buildings without raising the cost. Often, customers try to do this by providing non-structural insulated foam sheathing over alternative shear resisting wall elements or alternative structural foam sheathing combination products in place of traditional plywood and OSB applications. The unfortunate reality is that innovation in the shear wall realm has been restrained because these traditional products have been very creative in getting the building code to assign design values that institutionalize a design value based competitive advantage. The same is true with respect to seismic design coefficients (SDC).

Seismic Force-Resisting System	Response Modification Coefficient, R	Overstrength Factor, Ω_0	Deflection Amplification Factor, C_d
A. BEARING WALL SYSTEMS			
15. Light-frame (wood) walls sheathed with wood structural panels rated for shear resistance	6 ½	3	4
16. Light-frame (cold-formed steel) walls sheathed with wood structural panels rated for shear resistance or steel sheets	6 ½	3	4
17. Light-frame walls with shear panels of all other materials	2	2 ½	2

Table 1. Excerpt from ASCE 7 Table 12.2-1 Design Coefficients and Factors for Seismic Force-Resisting Systems.

For CMs on the west coast and in other high seismic regions, this raises the question: What would happen to the seismic design if I used an alternative bracing method or a structural sheathing material other than OSB in my wall panels? To find the answer, one must examine the SDCs found in Table 12.2-1 of ASCE 7 and, in particular, the Response Modification Factor or R factor.¹

As seen in Table 1, there are two possible R factors for light-frame walls: 6.5 for wood structural panels

(WSP) and 2 for all other materials. If a product competing with WSP does not have a code-defined research report* establishing its R factor as 6.5, it must use the code-assigned value for all other materials.

* 2009 IBC Section 104.11.1 **Research reports.** Supporting data, where necessary to assist in the approval of materials or assemblies not specifically provided for in this code, shall consist of valid research reports from approved sources, where the IBC defines **APPROVED SOURCE** as “An independent person, firm or corporation, approved by the building official, who is competent and experienced in the application of engineering principles to materials, methods or systems analyses, which is a registered design professional.”

A product with an R factor of 2 must be designed for 3.25 times the seismic load that a WSP shear wall is designed to resist. It is clearly important to CMs that, as new sheathing products come into the market, there is a rational engineering basis for evaluating their SDCs.

The History

In 1959, the Structural Engineers Association of California (SEAOC) Seismology Committee published the first edition of the Blue Book "Recommended Lateral Force Requirements." This seven-page document contained the four original R factors for seismic design (they were called "K" factors in those days). Fifty-five years and 81 R factors later, there is still not a definitive mathematical methodology to establish the R factor or, more broadly, any of the SDCs for a building system or the building components that make up that system. Instead, SDCs currently adopted by the building code are largely based on observations of past seismic performance and committee judgment.^{2,3,4,5,6} In other words, they are purely engineering judgments that are not based on proven science or equal energy mathematics that were readily available in the literature and that would have provided a more rational basis for assigning SDCs based on the actual tested performance of a system.

Purpose of the R Factor

The R factor, or response modification coefficient, results from simplifying the seismic design process so that linear elastic, static analysis can be used for most building designs.⁷ It is known from experience that structures can withstand greater forces, without collapsing, than they were designed for through inelastic strength behavior (see Figure 2).⁷ Designing for an expected seismic force using a fully linear elastic system would result in unnecessarily large lateral loads and a costly building design. Given this concern over the conservative nature of linear elastic design and its inherent high costs, the loads calculated for a fully linear elastic structure are reduced by the R factor to account for the fact the building is allowed to be damaged as long as it does not collapse (i.e., life-safety performance is provided, while allowing some building damage to occur). Thus, the larger the R factor, the smaller the design forces and the easier it is to find building components that can be used in the building design.

It is easy to see that the R factor serves as a basic measure of a system's ability to resist seismic loads and that it is the single most important parameter in seismic design. The R factor is represented graphically in Figure 2 along with the remaining two seismic design factors: the system over-strength factor, Ω_0 , which is a measure of the reserve strength (e.g., similar in concept to a factor of safety) of the building due to inelastic behavior; and the deflection amplification factor, C_d , which is

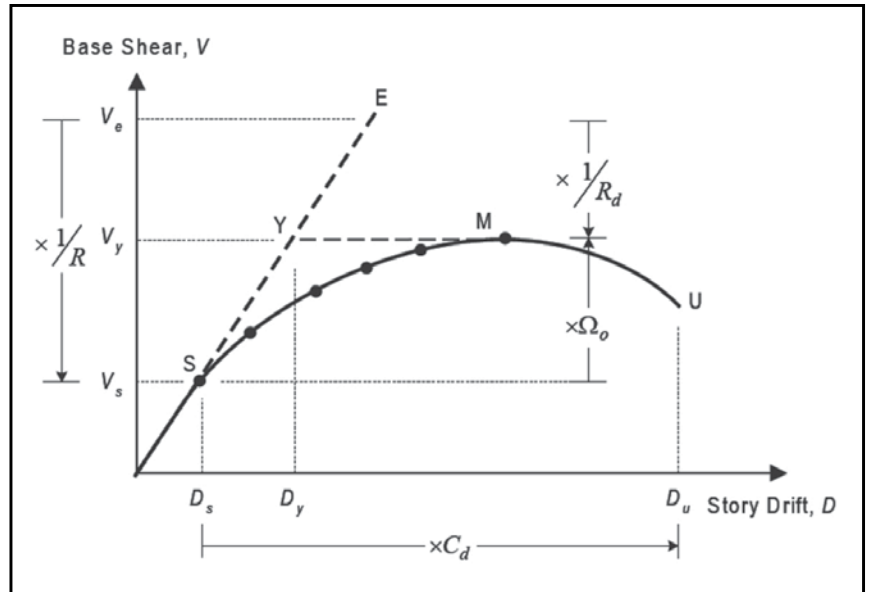

Figure 2. Inelastic Force Deformation Curve Showing Seismic Performance Factors (SEAOC Seismology Committee, 2008).

used to estimate the drift of the structure by increasing the calculated elastic displacement of the structure to account for inelastic deformations.

Figure 2 shows that the elastic seismic base shear force, V_e , is divided by the R factor to provide the design seismic shear force, V_s . The values of the R factor contained in the building code range from 1 to 8. Clearly, larger values of the R factor are better, given that they reduce the needed resistance to much lower seismic design forces.

The Creation of Competitive Disadvantage: Equivalency Testing

Since the historical building code seismic design methods did not lend themselves to readily available numerical methods of establishing SDCs, equivalency testing is often used to assign the same seismic coefficients as a system already contained in the building code for newly developed building components.

It is important to note that a component itself cannot actually have a set of SDCs, since these factors only apply to the overall building structure. Thus, the goal of equivalency testing is to determine if a seismic force-resisting system, with SDCs assigned by the building code, can use the component in the overall structural design and not to determine the actual SDCs themselves.

ICC-ES AC130, *Acceptance Criteria for Prefabricated Wood Shear Panels*, presents one proprietary and non-consensus-standard-based means of comparing prefabricated wood shear walls to light-frame walls sheathed with WSPs to establish equivalency to WSPs. This is accomplished by using data from cyclic shear wall testing (e.g., *ASTM E2126*) to calculate three parameters which are indicative of the component's ductility, deformation compatibility and overstrength.

Continued on page 20

Parameter	Equation
Ductility	$\frac{\Delta_U}{\Delta_{ASD}} \geq 1$
Drift Capacity	$\Delta_U \geq 2.8\% \cdot H$
Overstrength	$\frac{P_{peak}}{P_{ASD}} \geq 2.5$

Table 2. Equivalency Parameters for ICC-ES AC130.

Seismic Design Coefficients

Continued from page 19

Equivalency is established by comparing the parameters from the proposed component to maximum and minimum boundaries derived from a set of benchmark tests. If the parameters calculated for the tested product meet the prescribed limits, then it can use the same SDCs as light-frame (wood) walls sheathed with WSPs rated for shear resistance, which have an R factor of 6.5. If the system fails to meet these parameters, it is assigned an R factor of 2, which is used for light-frame walls with shear panels of all other materials. As described above, going from an R of 6.5 to an R of 2.0 has huge competitive product implications. If anyone wonders why WSPs have dominated the shear wall market, this is simply another area

where the code provides WSPs with a key barrier to entry and competitive advantages that severely restrain any company's ability to provide new innovative products into the market.

A summary of the ICC-ES equivalency parameters per this non-consensus-standard-based document is given in Table 2.

Maximum and minimum boundaries for the parameters were determined by analyzing a benchmark WSP shear wall data set consisting of 48 WSP shear wall tests, which included a variety of aspect ratios, design capacities, WSP thicknesses, nail sizes and nail spacing. The lower limits on the ductility drift capacity, and overstrength for the AC130 equivalency process is based the average parameters of WSP tests in the benchmark data set minus 1 standard deviation.⁸ Table 3 provides a summary of the parameter values from the benchmark data set used to select the parameter boundaries given in AC 130.

Since the limits on the three parameters are not based on the minimum tested parameter, some of the WSP tests in the database will fail to be equivalent.

Of the 48 tests in the AC130 database, 14 tests, or almost a third, are not equivalent to the AC130 criteria as shown in Figure 3. These non-equivalent tests have duc-

tility parameters that range from 6.4 to 43.4. Similarly, the overstrength parameters for the non-equivalent tests range from 2.5 to 5.2, and the drift capacities range from 2.3% to 4.1% of the height of the WSP shear wall tested.

This indicates that WSP tests with a wide range of behaviors could and do end up being non-equivalent under the AC130 criteria. The reason for this anomaly is that the AC130 task group considered each of the parameters separately and selected limits that more than 85% of the tests would exceed.⁹ However, in all cases, a test that failed one parameter meets the other two parameters. Thus, the 6%-12% of the data that failed each parameter must be summed to find the total number of tests passing the overall AC130 criteria, resulting in 29% of the tests failing to meet the equivalency requirements.

This means that an alternative component that has the exact same performance as one of the WSP walls in the AC130 database may be inappropriately rendered "not equivalent" by AC130.

As seen in Figure 3 and Table 3, the parameters for the WSP tests are highly variable. The fact that the test results for multiple component configurations is highly variable was recognized by the Task Group, as seen in the following statement:

Continued on page 22

Breakdown	Statistic	Normalized Parameter		
		Drift at Ultimate	Peak/ ASD Design Load	Ult. Drift/ ASD Drift
All Data	count	48	48	48
	max	5.5%	5.4	43.4
	min	2.3%	2.3	6.4
	Average	3.6%	3.1	20.3
	COV	21.3%	26.1%	44.9%
	Average + 1 STD	4.3%	3.9	29.4
	Average - 1 STD	2.8%	2.3	11.2

Table 3. Summary Parameters of the AC130 Database.

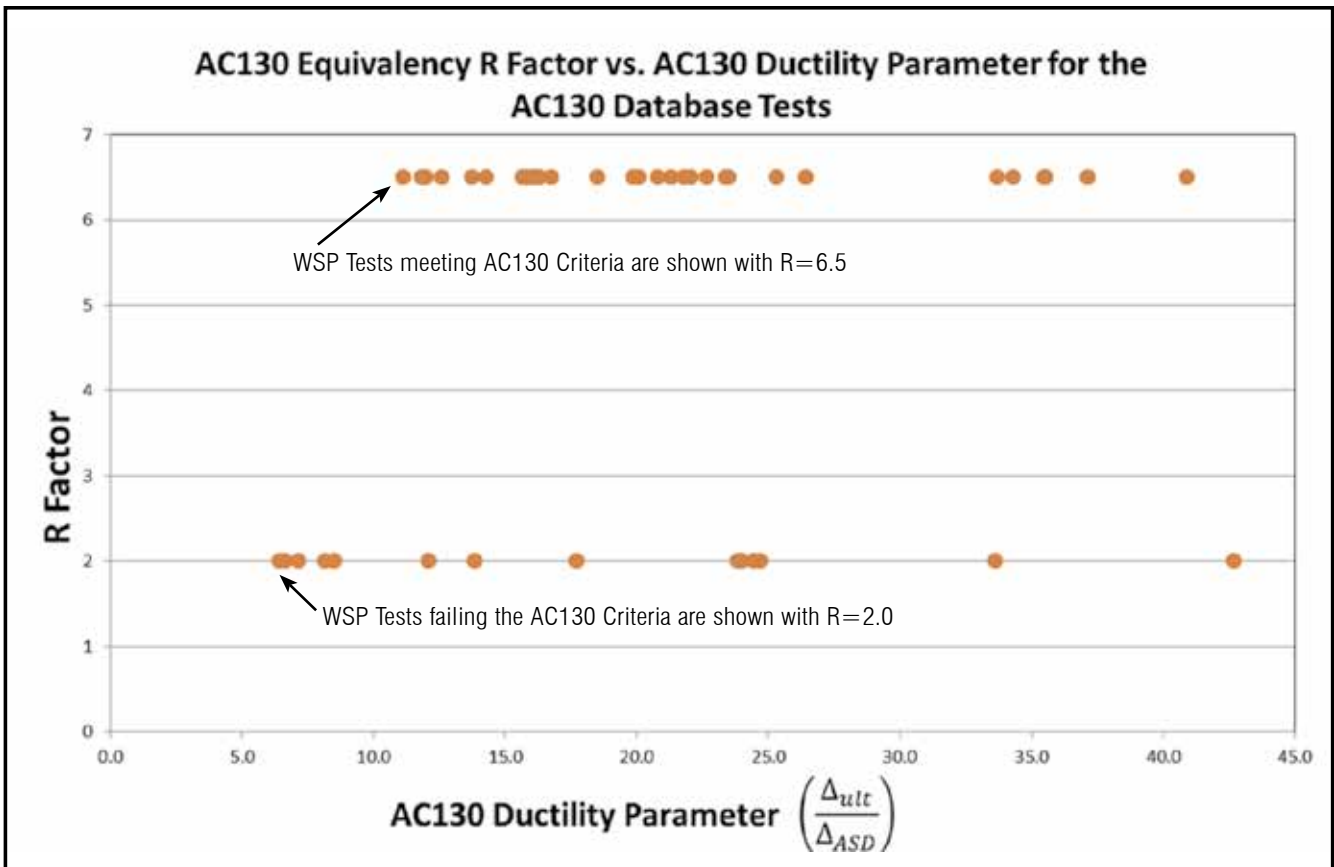

Figure 3. Plot of Benchmark Data used for AC130.

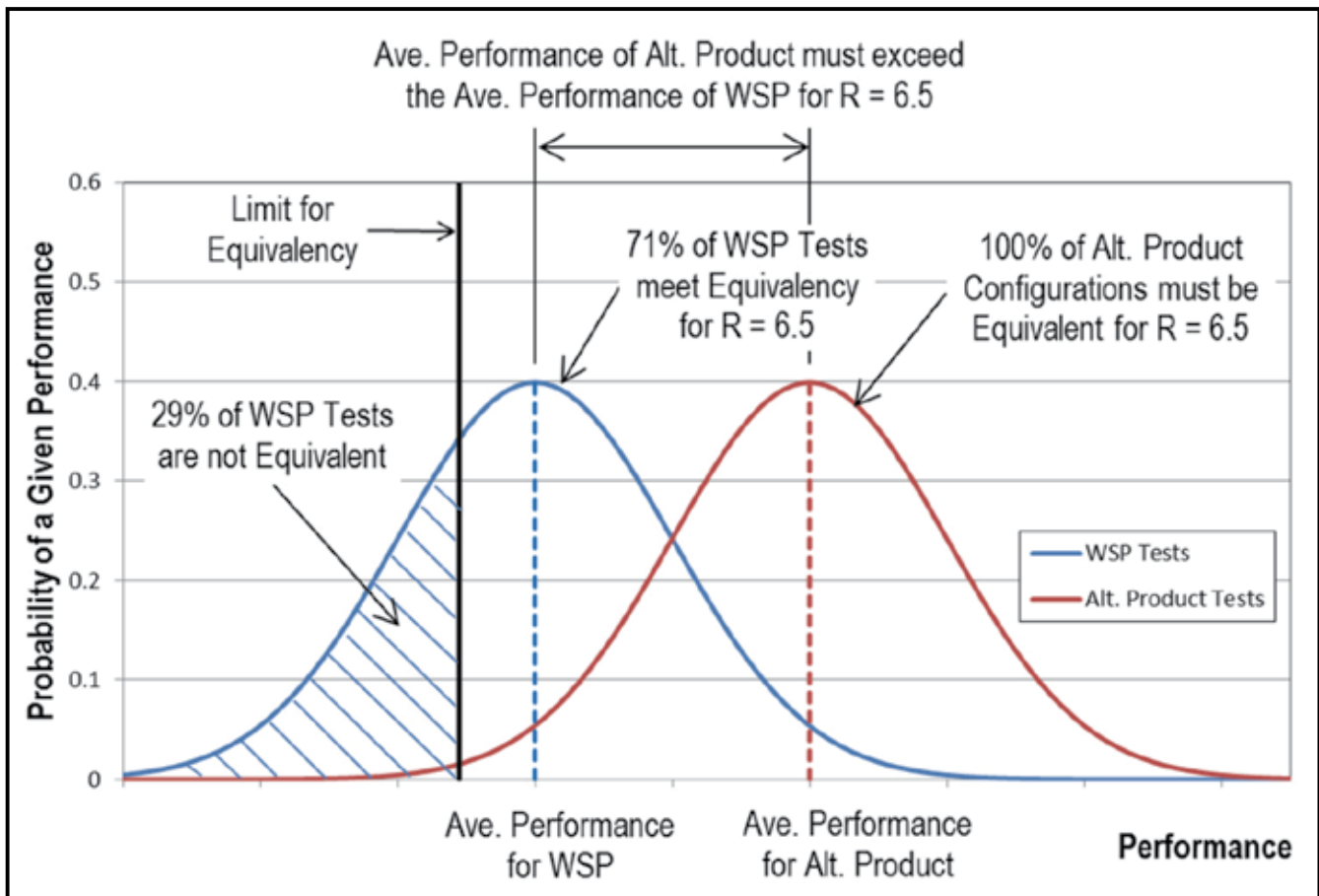

Figure 4. Illustration of AC130 Equivalency Methodology.

Seismic Design Coefficients

Continued from page 20

Given the large variation in performance expected with all possible building code-permitted permutations of the benchmark system, the Task Group judged that it was not appropriate for the proponent of a prefabricated shear panel to simply select test data from a single shear wall configuration to prove equivalency. Performance criteria established using this single data point may or may not be representative of the level of performance commonly associated with the population of walls that conform to the code-defined benchmark system.⁸

Despite the known variability of WSP, little allowance was made for the variability of alternative products. The Task Group states:

The Task Group intent was that the target parameters be compared against the average tested performance for each prefabricated shear panel configuration. It is not intended that each test replicate pass this criteria (too stringent), nor is it intended that some aggregate average of multiple prefabricated shear panel configurations be compared against the performance benchmark (too lenient).⁸

Therefore, as illustrated in Figure 4, the average performance of each configuration for an alternative product must be greater than the AC130 limits; while, in contrast, only a portion of the WSP shear wall configurations are actually greater than the AC130 limits.

In short, alternative products are not allowed to have the same range of performance as WSP shear walls. If WSP shear walls that fail to meet the equivalency parameters can use an R factor of 6.5, while alternative systems that fail to meet the equivalency parameters are required to use an R factor of 2, the ability of alternative products to compete in the marketplace is clearly constrained. All roads to a competitive market lead through equivalency to WSPs, a proprietary and non-consensus-standard-based method (AC130), and the private non-profit, ICC-ES.

Furthermore, in AC130, the checks on the overstrength and the ductility are performed independent of each other. However, as discussed by the 2003 edition of the *NEHRP Recommended Provisions and Commentary for Seismic Regulations for New Buildings and Other Structures*, the R factor results from a combination of the overstrength and the ductility of a system.

Checking the two factors separately neglects the interaction of the two components. This results in systems with less ductility and more overstrength being assigned an R factor of 2. As a consequence, OSB sheathed cold-formed steel stud walls, foam core panels, etc. can be inappropriately penalized.

Finally, the drift limit of 2.8% of the wall height can result in systems with good ductility and high initial stiffness being assigned an R factor of 2.

As shown in Figure 3, there are at least eight high-ductility systems that have an R factor of 2 due to the drift limit or overstrength checks. Figure 3 also clearly shows that there is no increase in the R factor as the AC130 ductility parameter increas-

es, when you compare all the data points with an AC130 ductility parameter greater than 11.0. This is contrary to the understanding that highly ductile systems are more earthquake resistant.

Conclusions

Newly developed alternative products, that have a sound engineering basis, may fail to meet the proprietary AC130 equivalency parameters and be considered not equivalent even when they have performance that is equivalent to or much better than that of WSP shear walls. It is therefore challenging, if not impossible, for new product development and innovation to efficiently take place because the AC130 process is simply an R factor equivalency approach where the R factor is hand-picked without any analytical basis. However, it is great for the “in” products, like WSP, because it creates a de facto competitive advantage in the marketplace. A better methodology for determining SDCs that can provide more accurate comparisons between different systems is critically needed and already exists in the literature. SBCA has used its extensive amount of industry test data to develop an energy based methodology that can provide more meaningful comparisons for testing and defining SDC equivalency.

This equal energy method uses basic calculus (you never thought you'd use that undergraduate class did you?) to measure the amount of energy dissipated by the lateral force-resisting system. The energy dissipated by the assumed linear elastic response is set as equal to the energy dissipated by the actual non-linear response. By equating the energy dissipated by the linear and non-linear responses, a formula for calculating the R factor can be derived. **SBC**

Part 2 of this article will expound on this linear vs. non-linear energy dissipation concept, called the Equal Energy Method.

references:

1. *Minimum Design Loads for Buildings and other Structures (ASCE 7-10)*; American Society of Civil Engineers; 2010.
2. *NEHRP Recommended Provisions for Seismic Regulations for New Buildings and Other Structures, 2003 Edition, Part 2: Commentary (FEMA 450-2)*; Building Seismic Safety Council, Washington, D.C.
3. “Seismic Force-Resisting Systems Part 1: Seismic Design Factors”; SEAOC Seismology Committee; *Structure Magazine*, January 2009.
4. “Establishing Seismic Equivalency for Proprietary Prefabricated Shear Panels: An Introduction to the Process”; Ronald F. Nelson; *Structure Magazine*, August 2008.
5. “New Rules for Evaluating Seismic Performance of Prefabricated Shear Panels”; Ned Waltz and Ronald Hamburger; *Structure Magazine*, August 2008.
6. *An Investigation of Structural Response Modification Factors*; Christopher Rojahn; Proceeding of the Ninth World Conference on Earthquake Engineering (Vol. V), August 2-9, 1988, Tokyo-Kyoto, Japan.
7. “A Brief Guide to Seismic Design Factors”; SEAOC Seismology Committee; *Structure Magazine*, September 2008.
8. *Establishing seismic equivalency to code-listed light-frame wood wall systems*; Ned Waltz, Tom Skaggs, Philip Line, and David Gromala; Proceeding of World Conference on Timber Engineering (WCTE), WCTE, Miyazaki, Japan; 2008.
9. “Qualifications for Equivalence: An Illustration and Discussion of New Seismic Evaluation Provisions”; Reynaud Serrette; *Structure Magazine*, August 2008.

Can you set up *and* build
these 7 trusses, in twenty-three minutes,
on your existing equipment?

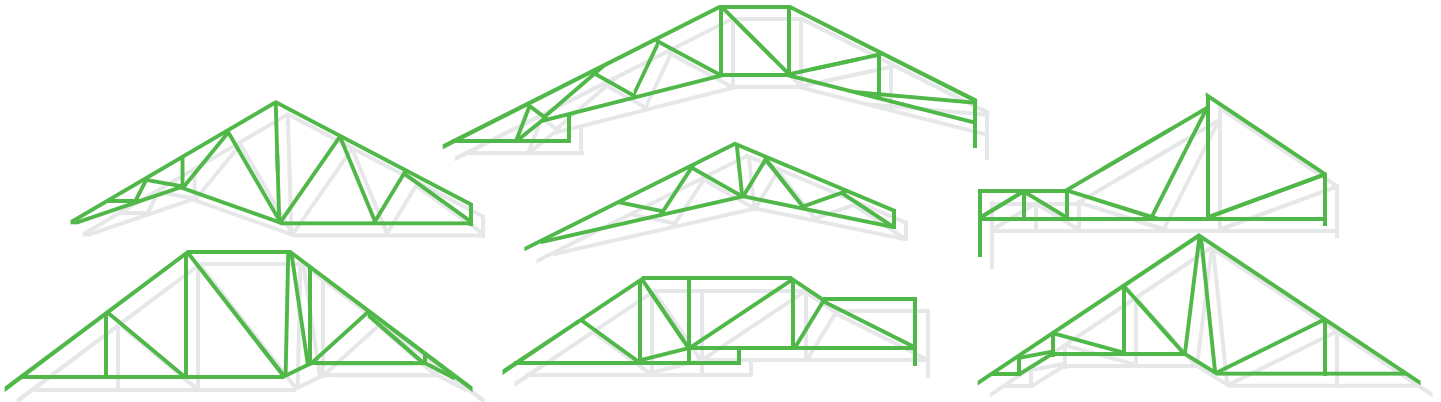

Yes you can.

With WizardPDS® Channels®

Achieve full automation, zero set up time, and save money by retrofitting your existing truss fabrication equipment. WizardPDS® Channels® will retrofit with virtually any truss assembly table; new, used or existing!

Old technology turned *state-of-the-art* with WizardPDS® Channels®

Think green. Retrofit. Save Green.



WizardPDS®
Automated Perimeter Definition System

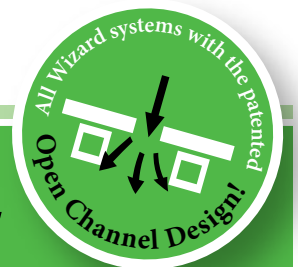

We bring the best together!

Toll free 800-344-3433 Ph. 612-521-9193 Fax 612-521-9307 www.eideintegratedsystems.com
Eide Integrated Systems, LLC PO Box 11397 / 3219 North Second Street Minneapolis, MN 55411-0397

TOP 10 Employee Training Tools

by Ben Hershey & Sean D. Shields

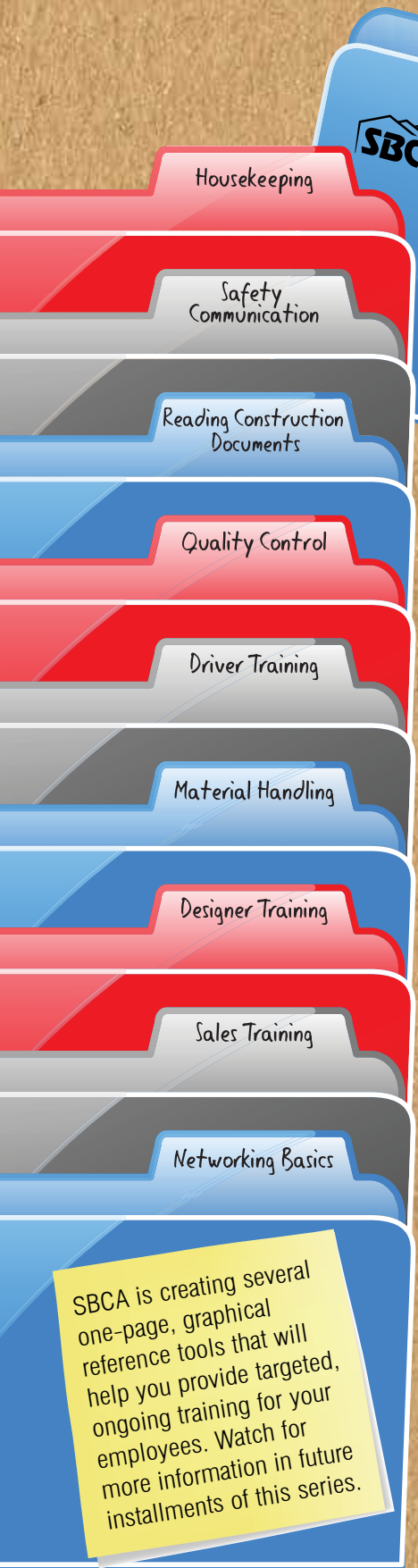

This is the first part of our ten-part series covering the top ten employee training needs for component manufacturers. As mentioned previously, making an overt and continual commitment to formal and on-the-job training goes a long way toward keeping your employees effective, efficient and satisfied. Providing continual training and professional growth opportunities not only strengthens your workforce, it makes a huge difference in retaining your most valuable asset.

The good news is that offering employee training is very straightforward. It doesn't have to take a huge financial or time investment, and you don't even have to create it yourself. In this article, we will cover some of the well-known issues associated with production. Given all the new people that are or will be coming into this industry, we will go over some industry best-practice, proven and effective training tools.

Assessing Skill Level

Gauging an employee's skill level and their proficiency with the tools of our trade is an essential first step. Assess whether each employee knows and/or has an aptitude to read truss design drawings and related construction documents; understand the fundamentals of building construction; and, appreciate the advantages of the component fabrication process as it relates to the structural performance of a building.

Your veteran staff members sometimes forget or assume that someone walking in the door knows what to do, but you really need to find out first. SBCA's **Truss Manufacturing Orientation (TMO)** was created exactly for this purpose.



Terminology

Start simple, help ensure that every employee understands the manufacturing concepts they witness, as well as the words they hear on the production floor. Most of the terminology in our industry is used daily. Confirming everyone learns and understands those terms can make a huge difference, not only in reducing the chance for errors through misunderstanding, but also in creating an inclusive work environment.



SBCA is creating several one-page, graphical reference tools that will help you provide targeted, ongoing training for your employees. Watch for more information in future installments of this series.

Safety Culture

To reduce the chance for accidents, injuries and illnesses, everyone in your plant needs to make safety and health issues as high of a priority as other issues, like sales, production and product delivery. To that end, it's vital all employees, especially new ones, are aware of their surroundings, including heavy machinery, sharp plate teeth, bunks of lumber, powered and unpowered hand tools, fork trucks and related situations that may threaten their safety.

A good first step toward that goal is to make sure that every employee is familiar with the entire production process. Whether they are new or veteran employees, conducting a walk through with a small group of your work force from time to time is an excellent way to review everything from steps in the production process to QC and safety expectations.

In addition, here are some handy guidelines all production workers should make into habits:

Five Basic Safety Rules for Non-Powered Tools

1. Keep all tools in good condition with careful maintenance.
2. Use the proper tool for each job.
3. Never use a damaged tool, and report the damage to a supervisor.
4. Operate all tools according to the manufacturer's instructions. When in doubt, ask your supervisor.
5. Use the correct personal protective equipment with each tool.

Five Basic Safety Rules for Powered Tools

1. Keep cords and hoses away from heat.
2. Disconnect tools from their power sources before service or cleaning, and when not in use.
3. Never yank a cord or hose to disconnect it.
4. Remain a safe distance away from your co-workers when they are using power tools.
5. Make sure all proper guarding is in place before use. When in doubt, ask your supervisor.



Tool Use

Speaking of tools, one of the basic aspects of production training is proper tool use. Two surprising examples of tools that are commonly misused in the production process are hammers and tape measures.

Gripping & Swinging Hammers

Having a proper grip on a hammer is very important. Practice grasping it lightly, but firmly. Avoid holding your hammer too tightly, to help prevent fatigue and injury to your wrist and arm.

Swinging a hammer properly will help an employee avoid injuries, as well as prevent damage to the surface being struck. Before swinging the hammer, first check your grip on it. Also, an employee should try not to use his or her wrist to create the force behind the hammering.

Reading a Tape Measure

Reading a tape measure is a very important skill in the production process. Tape measures clearly mark inches with black lines that go across the entire width of the tape. Between the inch marks are a number of shorter lines, which mark $\frac{1}{16}$ -inch measurements. These shorter lines are four different lengths. The longest lines (besides the inch marks) represent $\frac{1}{2}$ inches, the second longest show $\frac{1}{4}$ inches, then $\frac{1}{8}$ inches, and lastly, $\frac{1}{16}$ inches. Measurements in our industry are usually given as feet, inches and sixteenths.

Equipment Procedures

Beyond basic hand tools, today's component manufacturing operation is full of complex heavy machinery. Production equipment from component saws to gantry tables and roller presses can be very dangerous. Defining all safety warnings in the manufacturer's owner/operator manual during a walk through process is important and valuable.

Here are some general, practical guidelines employees should follow:

Continued on page 27

Considering Equipment? Consider Clark.

Stacking Systems? No Problem!!!



We Offer **Fully Electric** Horizontal & Vertical Truss Stacking Systems

Big Plates on Little Trusses?

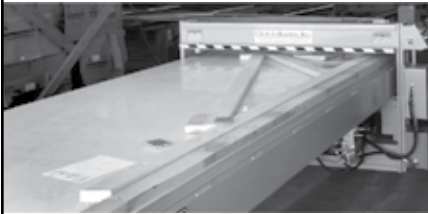

Try Our New **60 Ton** Jack Table!!!



Clark Industries, Inc.

816 Callan Street, Monett, MO 65708
Phone: 417-235-7182 • www.clark-ind.com
Email: general@clark-ind.com

Serving the Truss Industry Since 1987

New & Used
Models in Stock



For over 20 years, Lakeside Trailer has led the way in the component trailer industry with innovative ideas to assure your delivery operations remain efficient in today's competitive market. With more than 1700 truss trailers to our credit, Lakeside has perfected ways to reduce or eliminate your transportation concerns.

LAKESIDE
TRAILER MANUFACTURING, INC.

573/736-2966 • 573/736-5515 fax
www.rollerbed.com • lee@rollerbed.com



parting shots

Share your stories and photos with us! Send submissions to partingshots@sbcmag.info.

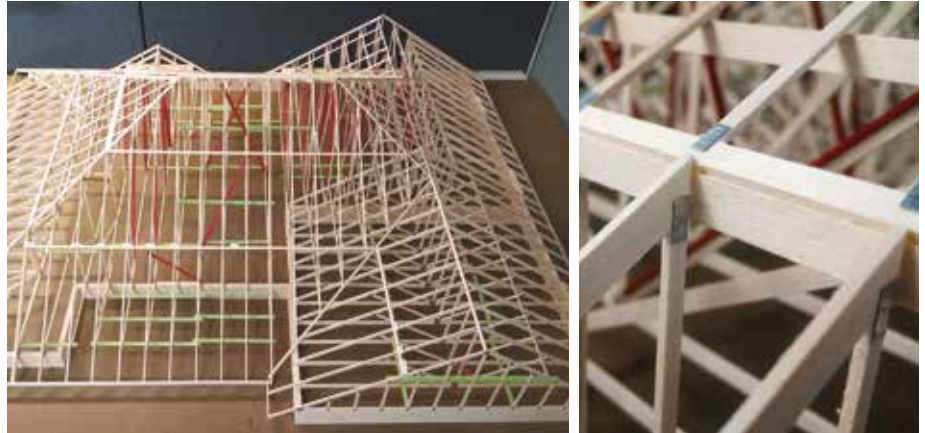

A few years ago, Lumber Specialties, a component manufacturer in Dyersville, IA, wanted a way to show proper bracing in a residential home. They asked Jason Gross, an intern in their design department at that time, to build an exact scale model of a roof truss system to accurately show diagonal bracing, lateral restraint, and T-bracing per BCSI.

Jason, who now works as a draftsman for BT Engineering PLLC, started by printing the truss design drawings out to $1/18$ scale. Using the printed trusses as a template, he hand cut each chord and web from basswood sticks. He then assembled each truss using wood glue and cut to scale each miniature connector plate. Finally, he installed color-coded bracing per the BCSI-B3 Summery Sheet.

It took Jason just over 100 hours to complete the project, which included 701 truss members and 1,328 truss plates. We think you'll agree it's impressive. **SBC**

To view additional photos of the model, see the online version of this issue at sbcmag.info.



build your skilled workforce at wfd.sbcindustry.com

Classified Ads

JOIN TOLL BROTHERS—2014 TOP WORKPLACE!

Nation's leading luxury home builder, seeks:

- **Building Components Designer:** Resp. inc. roof truss design, wall panel design & drafting of other house kit parts. All design & drafting completed in custom CAD system based on Autodesk. 4 yrs exp. designing wood-framed houses, exp. w/ MiTek design software (or equivalent) & AutoCAD skills are required.
- **Materials Estimator:** Resp. inc. reviewing plans, updating 'materials needed' list, generating invoices & training/supervising employees. 3 yrs material estimation exp. working with residential/commercial construction plans, MS Works skills & knowledge of CAD, material takeoffs & general construction are required. Excellent benefits. Apply to Jobs@TollCareerCenter.com or fax to 215-938-3060.



STRUCTURAL COMPONENT OPERATIONS REACHING FOR EXCELLENCE



Offering employee training is very straightforward. It doesn't have to take a huge financial or time investment.

Top 10 Employee Training Tools

Continued from page 25

1. Only trained and authorized workers should operate production equipment of any kind.
2. Keep all safety guarding in place.
3. Check all safety stops and controls at least once every shift.
4. Clear all obstructions away from the machinery.
5. Do not touch moving parts.
6. Do not wear loose fitting clothing or dangling jewelry that could get caught in a machine.
7. Wear safety glasses at all times.
8. Never leave equipment running when no one is around.
9. Check for damaged parts and repair before operating equipment.

It's also important for everyone in the production facility to know and understand "lockout/tagout" procedures. This is the practice of giving one person the responsibility to turn off and disconnect equipment and machines from their power source before performing maintenance or service tasks. In case of an emergency, it's also vital that everyone knows how to immediately shut down a piece of equipment.

Constant On-the-Job Training

Finally, consider getting your production supervision team together at least once a week to discuss what can be done better throughout the operation with regard to worker skills training and safety communication. Once the supervision team identifies an area for further training, don't limit the training to a single worker, but gather the entire team together for a few minutes of review. Those few minutes will always pay off for your operation. **SBC**

Ben Hershey is a Lean Management & Manufacturing Expert with 4Ward Consulting Group. The topic of Housekeeping will be covered in the June/July issue.



New Simplified Requirements

Quality-Focused

Customer-Centered

Best Practices

- Focused on programs that matter most to Component Manufacturers' customers.
- Streamlined certification requirements.

"We believe that these programs and their emphasis on best practices provide a priceless return on investment. There are no other business programs available that have such a positive impact on our bottom line the way SCORE does."

**- Steven Spradlin,
President of Capital Structures**



Efficient. Intuitive. Complete.

The concept of linear cutting has just been advanced to the next level. The ALS 4.0 Linear Saw helps you control costs, gain efficiencies and keep prices competitive. Optional automated in-feed and out-feed queue systems offer dramatic productivity improvements and labor savings. The ALS 4.0 can easily turn a two-man job into a solo performance!

**TO GET STARTED CALL
800.521.9790
OR VISIT ITWBCG.COM**

Watch the video to see for yourself how the ALS:

- ⌚ Cuts the shortest blocks and the longest scarfs, on the fly, in seconds.
- ⌚ Optimizes every stick of lumber it cuts, generating less scrap and more profit for you.
- ⌚ Pays for itself quickly by turning cutting into a one-man operation and improving your plant's overall capacity and productivity.



**Learn
More**



ITW Building Components Group



youtube.com/user/itwbcg