

STRUCTURAL BUILDING COMPONENTS™

THE FUTURE OF FRAMING

May 2012

www.sbcmag.info

Going Beyond Green

Net-Zero Pushes the (Building) Envelope



Plus...

Sealed Code Compliance Reports:
A Law-Abiding, Streamlined Alternative

...and more!

CHANGE SERVICE REQUESTED

SBC Magazine • 6300 Enterprise Lane • Suite 200 • Madison, WI 53719

PRSRT STD
U.S. Postage
PAID
Madison, WI
Permit No. 2223

Framing the
**AMERICAN
DREAM®**



ONE MISTEAK CAN THROW EVERYTHING OFF.

Everything has to fit together correctly – for your customers and for the success of your business. You need reliable tools and support to back you up. At MiTek, reliability is at the core of our commitment to you – in our industry-leading software solutions and our passion for your success. MiTek reliability has been proven for over 50 years with component manufacturers across the US – in our engineering and technical support, our industry expertise, and our commitment to making sure mistakes never happen.



Reliability you can count on.SM

Better Technology. Better Building.SM

© 2012 MiTek. All Rights Reserved

For reader service, go to www.sbcmag.info/mitek

Our Valued Supporters...

These companies provide significant sponsorship of the structural building components industry.

SBCTM magazine

Many thanks for their ongoing support!

Gold Advertisers

- > Clark Industries* (p. 20)
- > Eagle Metal Products* (p. 11)
- > Eide Integrated Systems, LLC* (p. 6)
- > ITW Building Components Group* (p. 24)
- > Lakeside Trailer Manufacturing, Inc.* (p. 11)
- > MiTek Industries, Inc.* (p. 2-3)
- > SBCA* (p. 23)
- > Simpson Strong-Tie Co.* (p. 9)



ITW Building
Components Group



SBCATM



*Indicates Charter Advertiser Status

Silver Advertisers

- > BCMC* (p. 20)
- > Metsä Wood*
- > Pennsylvania Lumbermens Mutual Insurance Co.
- > Wood Truss Systems* (p. 22)

Bronze Advertisers

- > Wasserman & Associates, Inc.

For more information about our 2012 Program Advertisers or advertising in general, visit sbcmag.info or call 608/310-6706.

Listing based on contracts received as of 4/19/12.

Publisher

Truss Publications, Inc.
6300 Enterprise Lane • Suite 200
Madison, WI 53719
Phone: 608-310-6706 • Fax: 608-271-7006
trusspubs@sbcmag.info • www.sbcmag.info

Editor

Steven L. Stroder
ProBuild • editor@sbcmag.info

Managing Editors

Emily Patterson
608-310-6747 • epatterson@sbcmag.info
Sean Shields
608-310-6728 • sshields@sbcmag.info

Art Director

Melinda Caldwell
608-310-6729 • mcaldwell@sbcmag.info

Editorial Review

Kirk Grundahl
608-274-2345 • kgrundahl@sbcmag.info
Suzi Grundahl
608-310-6710 • sgrundahl@sbcmag.info

Advertising Sales & Marketing

Peggy Meskan
608-310-6723 • pmeskan@sbcmag.info

Staff Writers for May

Ryan Dexter, PE. • Kirk Grundahl, PE.
Jim Vogt, PE. • Larry Wainright

Accountant

Mike Younglove
608-310-6714 • myyounglove@sbcmag.info

Computer Systems Administrator

Jay Edgar
608-310-6712 • jedgar@sbcmag.info

**Send all ad materials, insertion orders,
contracts & payments to:**

Truss Publications, Inc.
6300 Enterprise Lane • Suite 200
Madison, WI 53719
Phone: 608-310-6706 • Fax: 608-271-7006
trusspubs@sbcmag.info • www.sbcmag.info

contents

Page 12

Going Beyond Green



Net-Zero Pushes the (Building) Envelope

by Sean D. Shields

Page 16



by SBC Staff

Sealed Code Compliance Reports: A Law-Abiding, Streamlined Alternative

Editor's Message	7
Technical Q&A	10
Faces of the Industry	21
Parting Shots	22

The mission of *Structural Building Components Magazine* (SBC) is to increase the knowledge of and to promote the common interests of those engaged in manufacturing and distributing structural building components. Further, SBC strives to ensure growth, continuity and increased professionalism in our industry, and to be the information conduit by staying abreast of leading-edge issues. SBC's editorial focus is geared toward the entire structural building component industry, which includes the membership of the Structural Building Components Association (SBCA). The opinions expressed in SBC are those of the authors and those quoted, and are not necessarily the opinions of Truss Publications or SBCA.



85 Years of Service. Three Generations of Commitment.

- ✓ **New, state-of-the-art** component manufacturing & material handling systems by *industry leaders*.
- ✓ **Used & Reconditioned** machinery. Eide's warranty on reconditioned equipment meets or exceeds the new machine warranty.
- ✓ **Installation & Operator Training** included or available with any equipment purchase.
- ✓ **Table Retrofit** and upgrades for WizardPDS®.
- ✓ **Parts & Supplies.** Our parts department stocks thousands of parts and supplies for most brands of cutting and pressing systems. Custom and obsolete parts fabrication is our specialty.
- ✓ **Service & Repair.** Our service department offers complete repair, rebuilding & retro-fit services; in-house or on-site.
- ✓ **Equipment moving,** installation, and operator training services.
- ✓ **Auction Buyers Service;** We remove, ship and reinstall your equipment.
- ✓ **Overseas Buyers;** We can service and update your purchase as desired, containerize, ship and re-install the machine in your plant.

We know machinery.



www.eidemachinery.com

Toll free 800-344-EIDE | Eide Machinery Sales, Inc. | PO Box 11397 / 3219 North Second Street Minneapolis, MN 55411-0397

WizardPDS® Channels®

Drop-in table automation for existing press equipment.

The patented open channel design of WizardPDS® Channels® makes *retrofit possible to any existing table*. There is no need to remove or ship your tables anywhere; we perform all retrofit work right in your plant. In just a matter of days you'll be running at productively levels never before thought possible. *With over 100 systems in operation today, this isn't a concept, it's a promise.*

Need to update your line? Contact a WizardPDS® representative to learn more about new, used & reconditioned press system options.



WizardPDS® Your table, Automated.



**Think green.
Retro fit.
Save green.**

WizardPDS®
Automated Perimeter Definition System

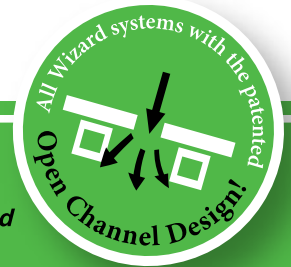

We bring the best together!

Toll free 800-344-3433 Ph. 612-521-9193 Fax 612-521-9307 www.eideintegratedsystems.com
Eide Integrated Systems, LLC PO Box 11397 / 3219 North Second Street Minneapolis, MN 55411-0397

For reader service, go to www.sbcmag.info/eide



editor's message

by Steve Stroder

The Most Valuable Week of the Year – BCMC!

Plan, Perform, Achieve in New Orleans

The warmer weather marks the beginning of spring, but my sights are set on fall when the BCMC show will roll into the Big Easy, the city of New Orleans. For me, BCMC is an annual opportunity to learn more about our industry. It's **the** place to learn about innovative ideas, new products, software, and equipment. You can meet just about any vendor who serves our industry and make valuable comparisons. This access to vendors and their in-depth perspectives, coupled with the opportunity to discuss ideas and common challenges with manufacturers from all over the country, makes the Building Community Making Connections event the most valuable week of the year for me.

Over the last 20 years that I have managed component operations, I have been fortunate to attend 14 BCMC shows. Each of these shows has helped me grow as a manager and a leader, bringing value to the companies where I've worked. My interest and involvement in the show has clearly evolved over the years. As a young manager attending my first show in 1993, I remember going to every educational session I could fit in my schedule. Even as a newbie back then, it was apparent to me that I could learn a great deal from these sessions and the seasoned managers/owners who were willing to teach me their best practices.

As my career in this industry developed, I found more and more valuable learning opportunities at the show outside of the BCMC sessions. Oh, I still go to the educational seminars and learn a ton, but I have also come to find a great deal of learning opportunities in networking with my fellow manufacturers. I have developed great friendships with these folks, which has allowed me to draw on their knowledge and share my own with them as we collaborate on issues throughout the year. A perfect example of this teamwork is the ongoing Southern Pine (SP) lumber design values issue. We have had countless conversations about this topic over the last several months and will likely have many more. We share our ideas and concerns as we look for the best grade solutions and implementation timing for adherence to the new design values that go into effect in June. We've also discussed the anticipated design value changes coming sometime after September once the full range of SPIB testing on SP is completed. This overall thought process goes well beyond SP to other species.

BCMC has evolved a great deal over the years as well. Based on member response, the show moved to largely CM-led educational sessions a few years ago. This proved to be a great format that we continue to use to this day with members teaching members about solutions for their businesses. Every BCMC, I walk away thinking I've seen the best educational sessions to date, but the tracks just keep getting better year after year. Our BCMC Committee and staff's knack for streamlining and improving the show is a tribute to their diligence and hard work; if you get a chance, please thank them for their service.

The economic downturn we have all experienced over the last five years or so has led the BCMC Committee to search for ways to revitalize the show and increase attendance. A couple of years ago, we added the BCMC Build to give something back to the cities we visit. The first year was a huge success in Charlotte, NC, when we built our first Habitat for Humanity home. Last year in Indianapolis, IN, we partnered

Continued on page 8

at a glance

- Access to vendors and their in-depth perspectives, coupled with the opportunity to discuss ideas and common challenges with manufacturers from all over the country, defines BCMC.
- Take part in BCMC Build and help construct a home for a very deserving family.
- This year's show features more workshops and business planning sessions to help component manufacturers prepare as the housing market reemerges.

Editor's Message

Continued from page 7

with Eli Lilly to build not one, but two homes for deserving families. BCMC Build has brought a great deal of pride and accomplishment to the members who have participated, and it helped reenergize the show just as we had hoped. This year, BCMC Build will do its part to help rebuild New Orleans. If you can, I encourage you to volunteer your time on the day of the build. You will enjoy the experience and likely make some new contacts and establish new friendships in the process.

Last year, a couple of BCMC Committee members, a past president and I were approached by a few long-standing supporters of the show. We were asked to consider scaling back BCMC in 2012. Their idea was to focus more on the educational and networking aspects of the show rather than bringing equipment. Shifting BCMC's focus this way would help cut costs for vendors during these trying economic times. This concept was taken to staff and the SBCA Executive Committee. The idea was discussed in depth with great care to consider how this change would affect the show. The Executive Committee (after receiving significant input from our vendors, CMs and the BCMC Committee) decided that this year would be a perfect time for this temporary change in the show's format, and with that, the winds of change were afoot.

Our BCMC staff sprang into action, working to find the means in Denver to accomplish our goal. Eventually, a decision was made to relocate the show to New Orleans as the BCMC Committee worked on ramping up the educational and networking aspect of the show. The process has come together and we are confident we have an outstanding show on tap for October. As Jason Blenker, BCMC Educational Co-Chair, says, education is the "meat on the bones of the conference" and we've really brought education front and center. Following the theme of Plan, Perform, Achieve, BCMC will include more workshops and business planning sessions to help component manufacturers enhance their business strategy and operations as the housing market slowly emerges from this long downturn. The layout of the show is even being updated to encourage more interaction between vendors and attendees.

Our 2012 BCMC will be a great show experience in an outstanding location. So join us in New Orleans on October 17-19. With top-notch educational sessions, BCMC Build and a new layout for the show, this could be the most valuable week of your year. I GUAR-ON-TEE. See you in New Orleans! **SBC**

SBCA Legal & Technical Fund



In preparation for the June 1 deadline for the design value change of No. 2 2x4 Southern Pine, SBCA is developing recommendations for truss and component manufacturers. Due to the additional resources used for the unexpected Southern Pine lumber issue, SBCA has started a legal and technical fund to help offset the costs. Support from donors helps the association move forward and continue to advocate for the structural building components industry on this and future potential changes to design values.

To view a list of donors or to make a contribution to this fund, visit:

sbcindustry.com/lumbersupport.php



SBCA Board of Directors

Officers & Executive Committee Reps.

- **President:** Steven L. Stroder • ProBuild
303-262-8500
- **President Elect/Treasurer:** Scott Ward • Southern Components, Inc.
318-687-3330 x106
- **Secretary:** Kenneth M. Cloyd • California TrusFrame LLC
951-657-7491
- **Past President:** Joseph D. Hikel • Shelter Systems Limited
410-876-3900
- **Dwight Hikel** • Shelter Systems Limited
410-876-3900
- **Kendall Hoyd** • Trussway Holdings, Inc.
713-590-8811
- **Joe M. Odgers** • Truss Systems, Inc.
770-787-8715

At-Large Representatives

- **Greg Griggs** • ProBuild Southeast • 770-428-2604
- **Jim Thomas** • Trussway Holdings, Inc. • 713-590-8958

Directors Representing Chapters

- **Phil Adams** • Northwest Building Components, Inc. • 208-687-9490
- **Keith Azlin** • U.S. Components, LLC • 520-882-3709 x131
- **Michael Balliet** • Builders FirstSource/Bama Truss & Components • 205-669-4188
- **Clyde R. Bartlett** • Bluegrass Truss Company • 859-255-2481 x100
- **Jimmy Broach, P.E.** • Atlantic Building Components & Services, Inc. • 800-475-3999
- **Dean DeHoog** • Zeeland Truss & Components • 616-879-1171
- **Rafael S. Del Valle** • Florida Forest Products • 727-585-2067
- **David A. Denoncourt** • Beau-Trusses LLC • 603-796-6200 x1
- **Jack Dermer** • American Truss Systems, Inc. • 281-442-4584
- **Barry E. Dixon** • True House, Inc. • 904-757-7500 x321
- **James C. Finkenhoefer** • Truss Systems, Inc. • 770-787-8715 x229
- **John Hogan** • Vivco Components • 816-449-2161
- **Steven M. Johnson** • Nelson Truss, Inc. • 608-884-6141 x400
- **Michael Karceski** • Atlas Components, Inc. • 815-332-4904 x103
- **Taft Ketchum** • PDJ Components, Inc. • 845-469-9191
- **Jess Lohse** • Rocky Mountain Truss Co. • 406-728-5356
- **Glenn McClendon** • Sun State Components of Nevada, Inc. • 702-657-1889
- **David Motter, P.E.** • Louws Truss, Inc. • 425-516-5964
- **Richard P. Parrino** • Plum Building Systems, LLC • 515-978-6269
- **John M. Presley, P.E.** • UFP Mid-Atlantic, LLC • 336-226-9356
- **David A. Raasch** • Lloyd Truss Systems • 507-387-4250
- **Michael L. Ruede** • A-1 Roof Trusses • 772-409-1010
- **Javan L. Yoder** • Stark Truss Co., Inc. • 330-479-8314

Associate Member Directors

- **Keith Lindemulder** • Nucor Corporation • 940-206-9582
- **Wayne Masengill** • Masengill Machinery Company • 423-586-7831
- **Jerry Vulgaris** • Trussed, Inc. • 951-436-3162



Testing, Innovation and Engineering Support

Simpson Strong-Tie is committed to delivering the most innovative products to our customers, which is why the company invests in research and testing. This commitment not only results in new products that improve building construction, but products that provide time-saving, value-engineered solutions. With more than 55 years of proven performance, customers count on Simpson Strong-Tie for innovative products, jobsite and engineering support, and unparalleled service.

We want to be your #1 supplier for truss, EWP and other structural component solutions. Let us demonstrate firsthand, contact us at (800) 999-5099 or www.strongtie.com.

SIMPSON
Strong-Tie

®

Wind Load Analysis: MWFRS vs. C&C

Learn more about determining
the best method of wind
load analysis.

ASCE/SEI 7-10, Minimum Design Loads of Buildings and Other Structures, lists two methods for calculating wind pressures: Main Wind Force Resisting System (MWFRS) and Components & Cladding (C&C). Choosing which method to use when designing uplift connections for trusses can raise a number of questions for building designers, code officials and truss designers.

Question

What is the best method of wind load analysis to use in truss uplift connection design and who is responsible for this work?

Answer

Selecting a method of wind load analysis depends on whether you are designing uplift connections for an individual member or a system. Let's start with some definitions for ASCE 7-10.

Components and Cladding (C&C): Elements of the building envelope that do not qualify as part of the MWFRS.

Main Wind Force Resisting System (MWFRS): An assemblage of structural elements assigned to provide support and stability for the overall structure. The system generally receives wind loading from more than one surface.

Either of these methods can apply to trusses, depending on the situation. By definition, a truss is an assemblage of structural elements, which would put it into the MWFRS category. The minimum uplift connection forces are provided in Table R802.11 of the International Residential Code (IRC) and Table 2308.10.1 of the International Building Code (IBC) for rafters and trusses used in

conventional light-frame construction. (For tables, see the online version of this article at sbcmag.info.) Both of these tables are developed using the MWFRS method as indicated by the reference in Footnote e to Figure 6-2 of ASCE 7-05 and Chapter 28 of ASCE 7-10.

Table R802.11 of the 2006 and 2009 IRC states:

e. The uplift connection requirements are based on wind loading on end zones as defined in Figure 6-2 of ASCE 7. Connection loads for connections located a distance of 20% of the least horizontal dimension of the building from the corner of the building are permitted to be reduced by multiplying the table connection value by 0.7 and multiplying the overhang load by 0.8.

Table 2308.10.1 of the 2012 IBC states:

e. The uplift connection requirements are based upon wind loading on end zones as defined in Figure 28.6.3 of ASCE 7.¹ Connection loads for connections located a distance of 20 percent of the least horizontal dimension of the building from the corner of the building are permitted to be reduced by multiplying the table connection value by 0.7 and multiplying the overhang load by 0.8.

However, a truss also receives wind load directly from the roof sheathing (i.e., cladding) and therefore acts as a component, which puts it into the C&C category.

¹ The 2012 IBC references Figure 28.6.3 of ASCE, which does not exist. It appears the intention is to refer to Chapter 28 of ASCE 7-10.



For more information on determining loads, along with a cover sheet that can be used by the building designer to define the loads or by the truss designer to get the loads approved, see the SBCA Load Guide available as a free Excel download at sbindustry.com/loads.php. The wind tab in particular discusses the design methodology for MWFRS and C&C. For more information on the SBCA Load Guide and its use, see these **SBC Magazine** articles available on the web page:

- Introduction to TLG – Part 1
- Introduction to TLG – Part 2

at a glance

- Based on the recommendations of the IRC, IBC and ASCE 7, truss or rafter uplift connections should be designed for applied wind loads using MWFRS analysis.
- Individual truss and rafter members should be designed using C&C generated wind loads.
- The SBCA Load Guide includes information about uplift connections for structural building components.

This crossover is illustrated in C26 of the Commentary for ASCE 7, which lists roof trusses as examples of both MWFRS and C&C (bold added to definitions to emphasize key concepts):

COMPONENTS AND CLADDING: ... Examples of components include fasteners, purlins, girts, studs, roof decking, and **roof trusses**. ... **The engineer needs to use appropriate loadings for design of components, which may require certain components to be designed for more than one type of loading, for example, long-span roof trusses should be designed for loads associated with MWFRS, and individual members of trusses should also be designed for component and cladding loads...**

MAIN WIND-FORCE RESISTING SYSTEM (MWFRS): ... Structural elements such as cross-bracing, shear walls, **roof trusses**, and roof diaphragms are part of the Main Wind-Force Resisting System (MWFRS) when they assist in transferring overall loads...

Combined Analysis

The truss industry uses a combined analysis, incorporating both the MWFRS and C&C method, to generate wind uplift and downward pressure loading conditions. MWFRS applies to the assembly of multiple parts, while C&C covers an individual part. SBCA recommends this hybrid approach. Most two-dimensional software analysis programs offer a choice of wind analysis methods when applying wind loads.

Using this combined analysis, truss or rafter uplift connections, at the plate line or as attached to a header, beam or girder, should be designed for wind load using the MWFRS analysis method, and individual truss or rafter members should be designed using the C&C analysis method. Similarly, gable frame uplift connections should be designed for wind uplift loads using the MWFRS analysis method, while individual members of the gable frame should be designed using the wind applied downward pressure loads developed through the C&C analysis method.

MWFRS	C&C
Truss Uplift Connection	Individual Truss Member
Gable Frame Uplift Connection	Individual Member of a Gable Frame for Downward Pressure Loading Conditions
Rafter Uplift Connection	Roof Covering, Wall Covering

Figure 1. Examples using the MWFRS and C&C analysis methods.

Issues to Watch

Regardless of the design method used, the truss designer needs as much loading information as possible from the building designer in order to design the trusses. The building designer is responsible for providing the structural design documents and all of the load and dimension information necessary to design the trusses. If a project does not require a licensed professional building designer, the owner or the owner's agent is responsible for providing this information. Although the IBC and IRC require all applicable design loads to be listed by the building designer in the structural design documents, this information is often lacking or not available to the truss designer at the time of design. If the truss designer does not have this information, assumptions may have to be made that can easily hamper an accurate and affordable design being performed.

Problems can arise if the end reactions on the truss designer's or truss design engineer's truss design drawings are different than the building designer's calculation of roof-to-wall anchorage forces. If this occurs, the issue falls under the building designer's scope of responsibility, per TPI 1-2007 and AISI S214-07, to resolve any differences in the reaction forces. **SBC**

To pose a question for this column, email technicalqa@sbcmag.info.

Clark Industries, Inc.
Since 1967—Monett, Missouri

Considering equipment? Consider Clark.

- Roof & Floor Truss Presses
- Multi-Head Truss Presses
- Modular Truss Presses
- Shuttle Presses
- Jack Presses
- H.D. Chord Splicers
- Floor Truss Machines
- Electric Horizontal Stackers
- Electric Peak-up Stackers
- Post & Column Machines
- Conveyor Systems
- Custom Machinery



800.743.9727

www.clark-ind.com

For reader service, go to www.sbcmag.info/clark

Serving the Truss Industry Since 1987

New & Used Models in Stock



For over 20 years, Lakeside Trailer has led the way in the component trailer industry with innovative ideas to assure your delivery operations remain efficient in today's competitive market. With more than 1700 truss trailers to our credit, Lakeside has perfected ways to reduce or eliminate your transportation concerns.

LAKESIDE
TRAILER MANUFACTURING, INC.

573/736-2966 • 573/736-5515 fax
www.rollerbed.com • lee@rollerbed.com

For reader service, go to www.sbcmag.info/lakeside

Going Beyond Green



Net-Zero Pushes the (Building) Envelope

by Sean D. Shields



Photo 1. Habitat for Humanity Sacramento's net-zero house under construction. The blue house pictured above represents how the home will look upon completion.

Fifteen dollars doesn't get you much these days. A few gallons of gas. A large pizza. A year's worth of utility bills...

It seems staggering, but it's true. The net-zero homes Habitat for Humanity Sacramento (CA) is building in its community will generate minimal monthly gas and water bills, but the credit the homeowners earn from their electricity bills should offset such costs. "Habitat builds homes for deserving families who have to put in 500 hours of 'sweat equity' into the home they receive," said Dan Wilson, Habitat's Director of Construction. "In return, we provide them with a 30-year, interest-free loan. The less they pay per month in utilities is more they can pay back on their mortgage."

Beyond super-sized energy efficiency, Wilson points out there are several other benefits to net-zero homes like the one they are currently completing in Sacramento (See photo 1).

These advantages turn into virtual talking points for component manufacturers to use in promoting the use of advanced framing techniques in green building and beyond. "Everyone thinks these [energy efficient]



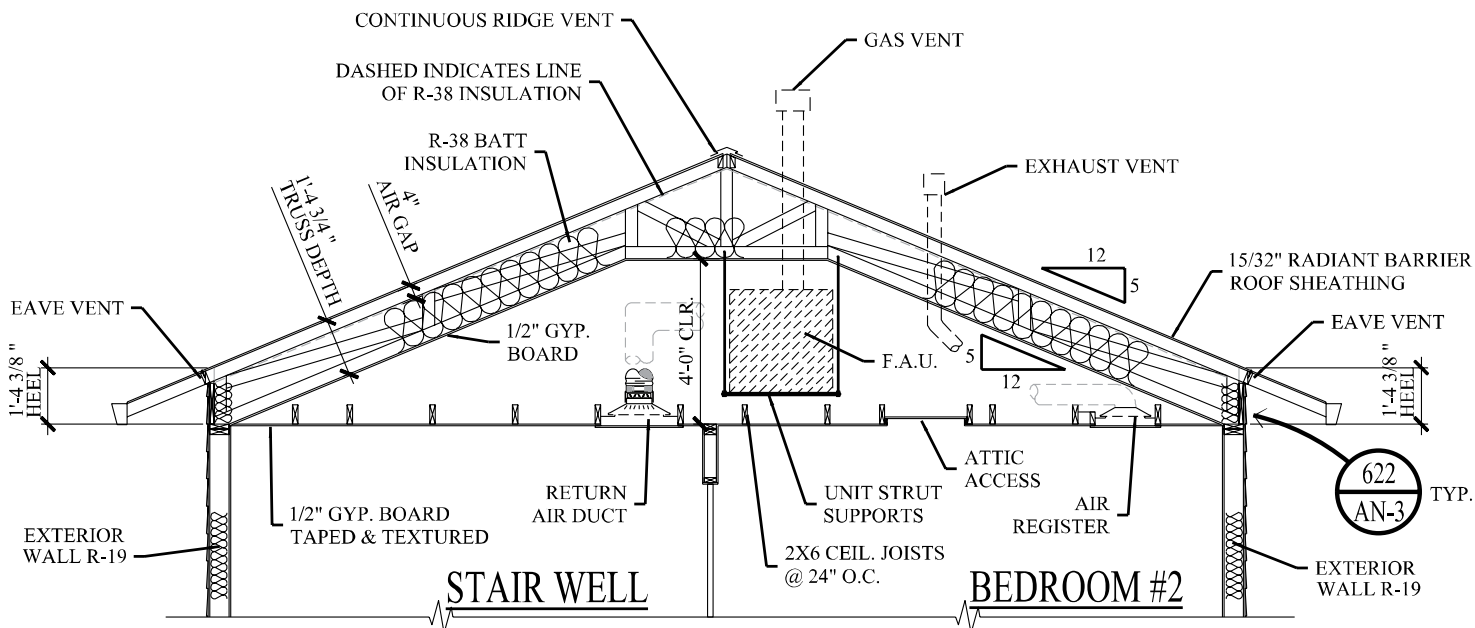

Figure 1. One key aspect of this home was to place the HVAC mechanicals and duct work in conditioned space, essentially insulating it inside the building envelope.

Beyond super-sized energy efficiency, there are many other benefits to net-zero homes.

homes cost more,” Wilson said. “The reality is that we have limited resources, so cost is a huge factor. These homes don’t cost more, they just reallocate the cost. The engineering and inspection costs are higher, but the ‘sticks and bricks’ costs—the cost of materials and labor—is significantly less.”

To see how it all evens out, let’s look at the home design itself, and then get into the ‘sticks and bricks’ cost savings that can be easily captured by component manufacturers and their builder customers taking this approach. With the structural component industry’s engineering know-how, there are many opportunities for increased sales.

Engineering Outside the Box

“We’ve worked with Habitat to build 14 LEED-certified homes (8 gold, 6 platinum) over the past few years,” said Norm Scheel, the Engineer of Record for various Habitat projects. “But this home goes way beyond those in terms of engineering and energy efficiency.” One key aspect was to place the HVAC mechanicals and duct work in conditioned space, essentially insulating it inside the building envelope (see Figure 1).

At first, Scheel looked at taking a traditional approach and using attic trusses to create a space to install the mechanicals. “But when we looked at the blocking that would have had to be done, I got concerned the HVAC professionals wouldn’t necessarily know what we were trying to accomplish,” explained Scheel. “Instead, we went with scissors trusses to hang the mechanicals off of, and then designed essentially a glorified drop ceiling to hang the drywall to.” (See Photo 2.)



Photo 2. Scissors trusses were used to hang the mechanicals.



Photo 3. Open metal-web joists were used for the floor.

Continued on page 14

Going Beyond Green

Continued from page 13

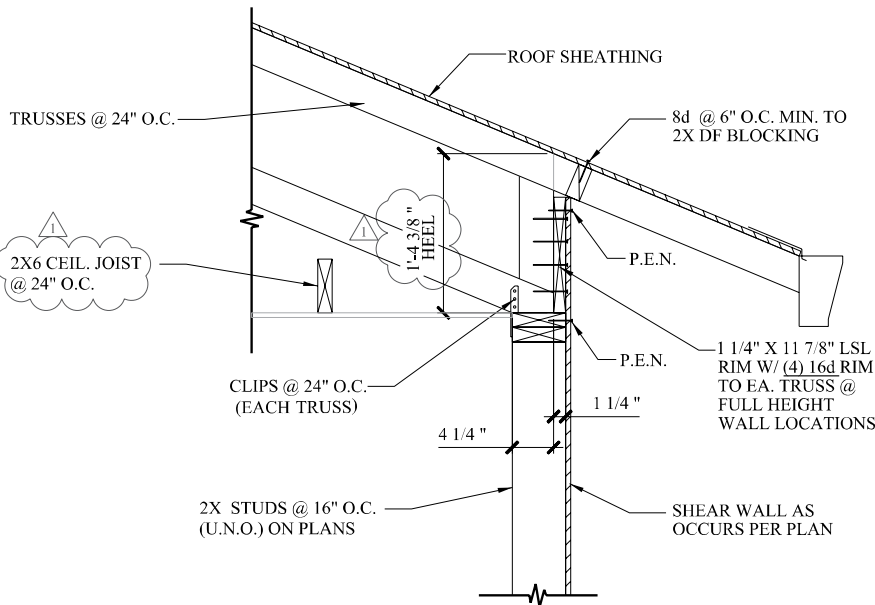

Figure 2. The heel heights of the trusses were raised to make more room for the mechanicals and duct work, and to allow for more insulation.

Scheel also raised the heel heights of the trusses (see Figure 2) to make more room for the mechanicals and duct work, and to allow for more insulation. “The raised heel is such a simple change, and it allows you to eliminate thermal gaps that traditionally occur at the outside connections,” said Scheel. “It also made it much easier to vent to the outside and even slightly reduces the pitch of the roof to make it easier to work on.”

The raised heel also allowed for a unique engineering approach. “We attached a 1-1/4” LSL to the outside heel to evenly distribute the load over the entire top plate of the wall,” said Scheel. “This even load distribution allowed us to eliminate all the headers above the doors and windows (see Figures 2 and 3 and Photos 4 and 5 below).

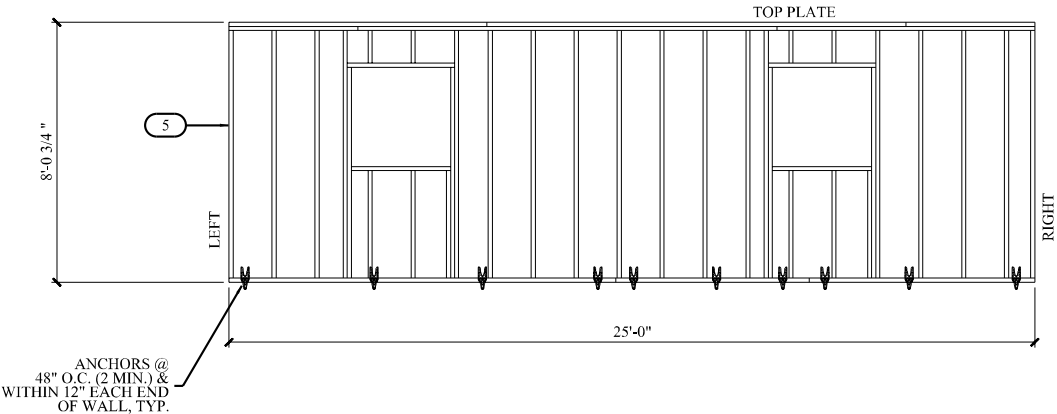

Figure 3. LSL was attached to the outside heel to evenly distribute the load over the entire top plate of the wall. This engineering approach eliminated the need for headers above the doors and windows throughout the house.

Beyond the elimination of headers, they framed the wall panels using 2x6 studs to create more room for insulation and added taped foam sheathing as the air and moisture barrier to the outside of the walls. Scheel also eliminated several studs in the exterior walls where interior walls met up (see Figure 4).

“This simple alteration has many benefits,” said Scheel. “First, you reduce the amount of wood, which saves money and lightens the weight of the



Photos 4 and 5. Examples of the result of using LSL to evenly distribute the load over the top plate. Note the lack of headers above doors and windows.

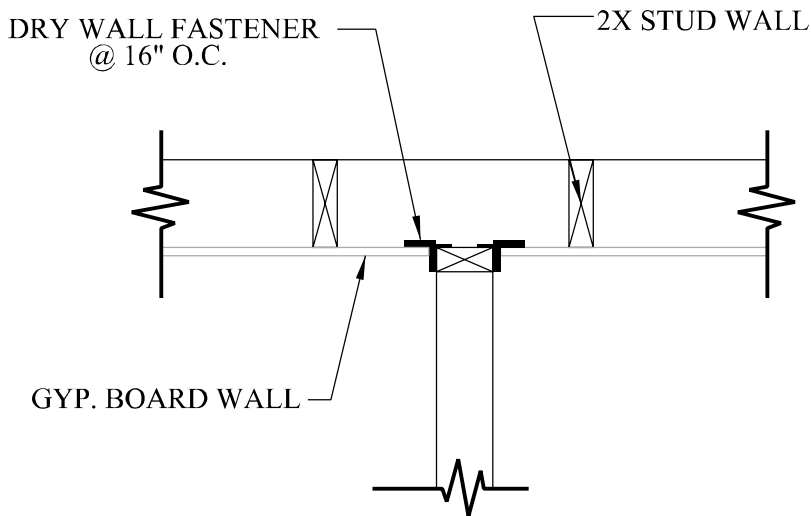

Figure 4. Several studs in the exterior walls where interiors walls met up were also eliminated.

wall during framing. Second, you can more easily place insulation in that cavity, which has a much higher R-value than wood, much like what we accomplished above the doors and windows. Third, it means that down the line it is much easier to move or eliminate interior walls during remodeling.” As a result, the walls in this home have a whopping R-value of 26.5!

Trusses Gone Wild

“I thought of this project as ‘trusses gone wild,’” said Wilson. “I’ve been working in this industry for 29 years, and I have never put the HVAC mechanicals in conditioned space before.” At first, Wilson and others on the project were concerned the scissors truss and dropped ceiling arrangement would be costly, but it worked out to be about the same cost as a more traditional approach. “There were 16 trusses. A typical attic truss package would have cost around \$3,200, but these scissors trusses were closer to \$2,600,” said Wilson. “Of course, there was an extra layer of drywall for the dropped ceiling, so we broke even.”



Photos 6. Siding installation posed a bit of a challenge, which was solved by adding extra furring strips to attach the siding.

“You certainly couldn’t have accomplished it at that cost using conventional framing techniques,” said Wilson. He pointed out that all the professional framers they employ have years of conventional framing experience, but they have all come to embrace componentized framing and see it as the superior construction method.

One of those framers is Terry Hardin. He was the lead framing supervisor for the net-zero home. Hardin has been a carpenter framer in the San Francisco Bay area for over 34 years. He got into framing right out of high school, and had always used conventional framing techniques before coming to Habitat. “At first, I was not a big fan of components,” said Hardin. “My initial impression was that it wouldn’t structurally work. I had to see it to believe it.”

Four short years later, Hardin can’t imagine why anyone would frame a house any other way. “It’s faster, cheaper and easier,” said Hardin. “It’s significantly lighter to work with, there is so much less waste on the jobsite, and in the end, you get a much better insulated envelope.”

On this particular job, Hardin was in for an additional surprise. “I had built this building’s floor plan five to six times before. I thought I knew exactly what we were doing,” explained Hardin. “They told me to take a closer look at this plan, and I was amazed at what they did with this house. Raising the heel heights, taking out the headers and eliminating the channels at the intersecting walls took a lot of weight out of the framing.”

The biggest challenge Hardin had to overcome on the project, besides working with a framing crew made up almost entirely of inexperienced volunteers, was figuring out how to attach the siding with all the extra foam sheathing and moisture barrier on the exterior walls. “We ended up with an 8-½” thick wall, by attaching extra furring around the windows and corners, we were able to work out a solution.” (See Photo 6.)

Selling the Revolution

Not every builder is going to have the same motivations as Habitat to build a net-zero house. However, changes in the energy code, combined with an increased public awareness of the green building movement, do appear to be driving an increasing number of builders toward considering green construction (see “The Blooming of Green Homes” from April 2012). Now appears to be an opportune time for component manufacturers to market themselves and their ability to do advanced framing to builders, within the context of green and energy efficient construction. For a component manufacturer’s perspective, see “Faces of the Industry” on page 21. **SBC**

See the online version of this article for more information about Habitat for Humanity and their net-zero homebuilding efforts.



Sealed Code Compliance Reports: A Law-Abiding, Streamlined Alternative

by SBC Staff

When it comes to code compliance for your new product, consider a road less traveled that can be much quicker and more robust than the traditional path.



Any innovation in building construction, whether it's a new product, material or method, needs to be compliant with the building code before it can be implemented or used in the field. Traditionally, obtaining code compliance for a product can be a complicated, sometimes messy, and certainly a drawn-out process. Not for the faint of heart, code compliance can turn into a saga spanning well over a year, requiring significant resources. In turn, the existing process creates a barrier to bringing a revolutionary product or process to market.

Fortunately, the Structural Building Components Research Institute (SBCRI), utilizing the staff of Qualtim, is offering a new, streamlined approach to code compliance. It's a road less traveled that can be much quicker and more robust than the traditional path, because it is focused solely on complying with existing law. SBCRI makes use of an efficient approach for testing and analysis. The results of the testing are summarized in a Technical Evaluation Report (TER), which is intended to assist those who enforce the codes and make the final determination of a product's compliance with the code.



SBCRI has a maximum testing area that is 30' wide by 32' high by 90' long.



SBCRI can test any building product or method, and

Firmly based on generally accepted engineering methods and code compliance requirements, the TER defines a product's performance benchmark and the rationale used to determine comparative performance. The TER is also affixed with a professional engineer's seal.

Overall, the goal of a TER is to:

1. Provide a transparent set of design values that are either defined by or implied by the International Residential Code (IRC), International Building Code (IBC), International Energy Conservation Code (IECC), International Green Construction Code (IgCC) and any referenced consensus standards as they relate to structural framing.
2. Define a performance benchmark and the logic paths for comparative performance, which SBCRI calls comparative equivalency.
3. Provide a technically reasonable foundation upon which to make engineering judgments when using generally accepted engineering methods in concert with the code compliance requirements.
4. Keep the outcomes understandable and simple to follow and use.
5. Facilitate a level playing field, allowing for fair and understandable product development.

In essence, SBRCI intends the TER process to help foster creative engineering innovation in the construction industry.

How Does It Work?

First, SBCRI meets with a client and evaluates their proposed building product, material or method. SBCRI's registered professional engineering staff help identify the sections of the building code that apply to the client's concept and define the need for a code-compliance evaluation. SBCRI then develops a series of test protocols to conduct structural testing and establish that the client's concept is a code-compliant alternative.

ANSI/ACCLASS certified as an ILAC-MLA accredited testing agency, SBCRI meets the requirements of ISO/IEC 17025 for all its testing techniques used to determine a structural product's real-life design limit states. SBCRI tests products as they would actually be installed in a structure to resist the same loading conditions encountered in the field. This "in-situ" testing, combined with its technical and engineering staff's structural building component expertise, provides the foundation for the TER.

Continued on page 18



and replicate "real world" loading conditions.



SBCRI has the ability to conduct traditional single-element testing as well.

...Code Compliance

Continued from page 17

Technical staff compiles and analyzes the resulting test data and generates the TER, which is in turn signed and sealed by one of its professional engineers. Therefore, the TER process provides a code-compliant evaluation that references sufficient test data and associated engineering analysis to assure building code equivalency for an alternative material, product or assembly.

As the ICC Evaluation Service states in its "1.0 PURPOSE" statement, "ICC-ES evaluation reports assist those enforcing model codes in determining whether a given subject complies with those codes...Approval for use is the prerogative and responsibility of the Code Official; ICC-ES does not intend to assume, nor can ICC-ES assume, that prerogative and responsibility." A TER and other Approved Sources perform this function.

Do TERs Comply with the Law?

The simple answer is yes! Adopted into local or state law, the building code has key provisions that make creative and innovative testing and engineering work possible (see sidebar on page 20).

SBCRI and Qualtim can provide transparent design values that are either defined or implied by the building code (IRC, IBC, IECC, IgCC, referenced consensus standards, etc.). SBCRI calls the latter comparative equivalency design values.

Firmly based on generally accepted engineering methods and code compliance requirements, the TER defines a product's

performance benchmark and the rationale used to determine comparative performance. The TER is also affixed with a professional engineer's seal. Once a product's design limits are known, it can be compared to other products on a level playing field basis, which promotes creative engineering and innovation in the building construction industry.

Concluding Thoughts

When a company looks for product development testing, engineering analysis, design value development and code-compliance assistance, it wants to:

1. Get the product or idea/innovation to market quickly;
2. Work with professionals who have expertise in the industry;
3. Navigate the code compliance process as efficiently as possible; and
4. Obtain a sealed report documenting the product's code compliance

All of this is possible through SBCRI's Technical Evaluation Report (TER) process.

If you have an idea for a new product, consider SBCRI's streamlined TER approach. The goal is simple: Define the code compliant benchmark, test your product against that benchmark, and compete on a fair and understandable basis. It may make the difference between a product successfully brought to market that generates sales immediately, and one whose sales never take off in the way that the owner expected. **SBC**



SBCRI's capacity to conduct limitless "in-situ" testing sets it apart from all other facilities.



This code-compliance approach is a 'portal' to success.

Test #1 – 3/8" WSP & 3,935 lb. 1/4" Quick Tie (QTG) Hold-Down Connector – 519 PLF

Tests can be conducted monotonically, cyclically or both.

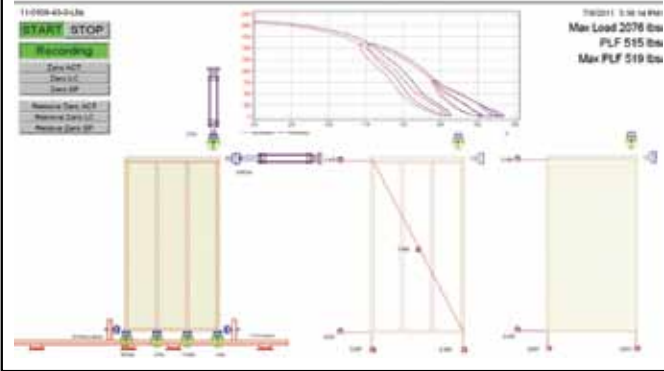

If you have an idea for a new product, consider SBCRI's streamlined TER approach. The goal is simple: Define the code compliant benchmark, test your product against that benchmark, and compete on a fair and understandable basis.

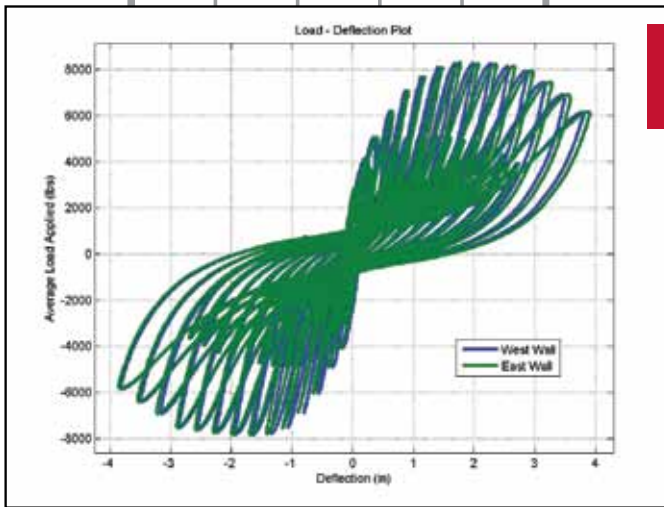

Test results are compared to a benchmark to ascertain code compliance.

For more details about how to test your product, go to sbcri.info.



access in the marketplace.

Effect of Applied Vertical Load and Hold Down Connector in an ASTM E72/E564 Single Element Test on Nominal Unit Shear Capacity (plf)

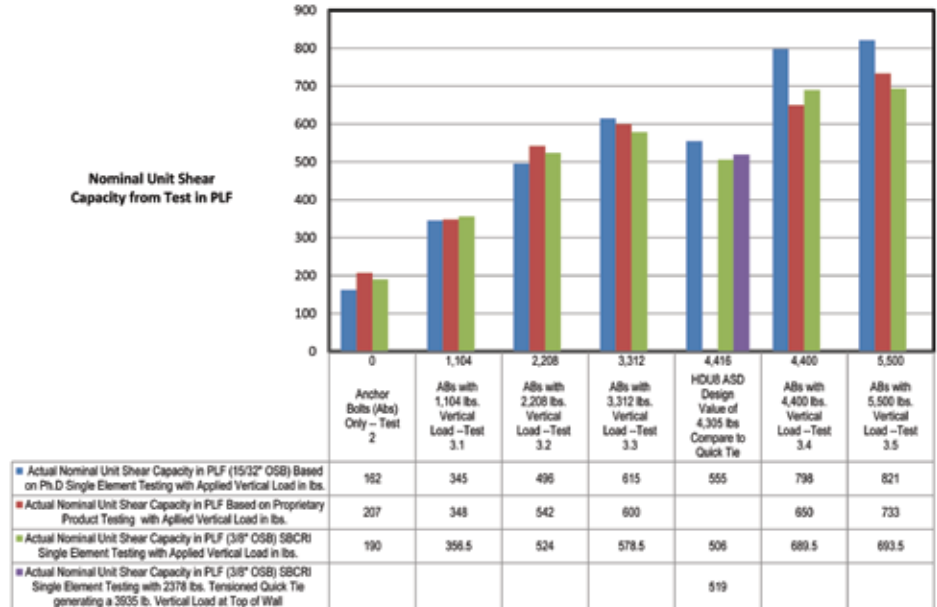

SBCRI's data collection system allows it to chart the strength and flow of loads in real-time.

The IBC & Established Law (as adopted) Provide These Definitions:



- APPROVED AGENCY – “An established and recognized agency regularly engaged in conducting tests or furnishing inspection services, when such agency has been *approved*.” SBCRI meets the code definition of an Approved Agency.
- APPROVED SOURCE – “An independent person, firm or corporation, *approved* by the *building official*, who is competent and experienced in the application of engineering principles to materials, methods or systems analyses.” SBCRI furthermore meets the definition of Approved Source.
- APPROVED – “Acceptable to the code official or authority having jurisdiction.”
- 104.11 Alternative materials, design and methods of construction and equipment. The provisions of this code are not intended to prevent the installation of any material or to prohibit any design or method of construction not specifically prescribed by this code, provided that any such alternative has been *approved*. An alternative material, design or method of construction shall be *approved* where the *building official* finds that the proposed design is satisfactory and complies with the intent of the provisions of this code, and that the material, method or work offered is, for the purpose intended, at least the equivalent of that prescribed in this code in quality, strength, effectiveness, *fire resistance*, durability and safety.
- 104.11.1 Research reports. Supporting data, where necessary to assist in the approval of materials or assemblies not specifically provided for in this code, shall consist of valid research reports from *approved* sources.
- 104.11.2 Tests. Whenever there is insufficient evidence of compliance with the provisions of this code, or evidence that a material or method does not conform to the requirements of this code, or in order to substantiate claims for alternative materials or methods, the *building official* shall have the authority to require tests as evidence of compliance to be made at no expense to the jurisdiction. Test methods shall be as specified in this code or by other recognized test standards. In the absence of recognized and accepted test methods, the *building official* shall approve the testing procedures. Tests shall be performed by an *approved agency*. Reports of such tests shall be retained by the *building official* for the period required for retention of public records. **SBC**

BCMC
BUILDING COMPONENT
MANUFACTURERS CONFERENCE

October 17-19
bcmcshow.com



Exhibit in Vibrant New Orleans!

- Market your Company and Brand
- Face to Face Relationship Building with Current and Potential Customers
- Engage in the Structural Building Components Industry
- New Sponsorship Opportunities



Watch for your Exhibitor Information Packet!

For reader service, go to www.sbcmag.info/bcmc

faces of the industry

BUILDING Communities | **MAKING** Connections



NAME: Corey Magelby

COMPANY: Homewood Truss (Sacramento, CA)

POSITION: Truss Design & Sales

YEARS IN THE INDUSTRY: 23

- | • **How did you get into doing truss design and/or get started in the components industry?** I graduated from college with a degree in construction management and engineering. Designing trusses seemed like the perfect fit to use that knowledge. I started with Latham Truss, then went on to be a co-owner of Western Wood Fabricators, but when we had to close our doors four years later, I came to Homewood.

money on the cost of materials, and made more room for insulating the walls and roof at the connection points.
- | • **What is your favorite part about working in the components industry?** Designing components. I enjoy having the ability to continually evolve their layout and application. There is a lot of room to innovate and it gives me the opportunity to influence changes in construction.
- | • **What do you think about the concept of “green” building?** Unfortunately, “green” has become a fad word. Green can mean simply using recycled materials, or making sure your lumber comes from within a few hundred miles, but there are a lot more “green” opportunities for improving the house.
- | • **What term do you prefer instead?** I think component manufacturers can play a significant role in green building standards, and collaborating with engineers and builders to meet the demands of changes to the energy code, in providing “advanced framing” options.
- | • **What’s an example of advanced framing?** For instance, on the net-zero home in Sacramento, we eliminated the headers above all the windows and doors and raised the heel heights of the roof trusses. We took a lot of wood out of walls (which is certainly “green”), saving the builder
- | • **Why isn’t everyone doing this, then?** Builders, architects and engineers are focused on how the building comes together. Telling a builder they can build a house without headers is going to challenge a basic assumption they make about how houses are constructed. Their initial reaction is going to be, “that won’t work.” A big challenge for component manufacturers is to convince the builder, or architect or engineer, that it will work.
- | • **What’s the trick in convincing them?** The easiest route is having done it before and having an example to show them. Beyond that, you really need to be involved on the ground-floor, during the initial design phase. If you can work with the architect or engineer from the beginning, it’s a lot easier to convince them to put it in the original plans, as opposed to getting them to change it later. We are all used to selling a product, but in this case, we are also selling a concept.
- | • **If you could change one thing about how the residential construction industry works, what would it be?** To increase communication between all the players within the residential construction industry and create a greater sense of team without discounting any part of process. Every aspect is vital to completion of the project.
- | • **What do you do to relax?** I do a lot of biking, hiking, golf, anything that gets me outdoors. I also like to watch my boys play sports. **SBC**

Look for more insight from fellow component manufacturers in upcoming issues as we continue this new column. If you would like to share your thoughts on an industry topic, contact Sean at sshields@sbcmag.info.

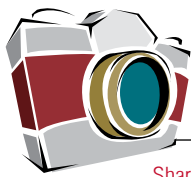

parting shots

Share your stories and photos with us! Send submissions to partingshots@sbcmag.info.



EAGLE METAL

True.

As a family owned, full-service plate supplier, Eagle Metal serves independent truss manufacturers. For more than 20 years, we have provided component manufacturers with quality connector products, structural component software and dependable, customer-first support.

Partner with us today.

Connector Products • Structural Component Software • Customer-First Support

eaglemetal.com • 1-800-521-3245

For reader service, go to www.sbcmag.info/eagle



The March 2012 issue of **SBC** highlighted the benefits of assembling wood roof trusses on the ground. Here, we see an example using cold-formed steel trusses for a Winco Foods Store in Mesa, AZ. Westco Steel Systems designed the store's roof so the contractor could build each section on the ground and hoist it into place as a fabricated section.



Four workers assembled, sheathed and set the roof in just four days, about half the time and labor it would have taken to individually install the trusses, not to mention greatly increasing safety and reducing the need for complicated fall protection systems. Westco Steel Systems designs many of its projects so the roof can be built on the ground at the jobsite, says Kimbo Godwin, President of Westco, noting, "With the correct planning, the cost of rigging and lifting is very small compared to the cost savings of building on the ground." **SBC**



Photo Contest



The next online photo contest is underway, and the winner will be featured in an upcoming issue of **SBC**. Email your photos* (high resolution, 300 dpi, preferred) today, along with a brief description, to epatterson@sbcmag.info.

*Photos submitted may be used in **SBC Magazine** or other SBCA materials.



Wood Truss Systems inc.
MANUFACTURERS' REPRESENTATIVES

**New & Used
Truss & Wall Panel
Production Equipment**

Featuring Innovative New Machinery Solutions:

Wood Runner

Automated Lumber Retrieval System for linear saws
Fast, Efficient, Affordable, Laser Guided

Contact us for additional information

www.WoodTrussSystems.com
765.751.9990 **SBCA MEMBER**

For reader service, go to www.sbcmag.info/wts

Take Your Plant to New Heights with SCORE

REACH FOR EXCELLENCE

“There are no other business programs available that have such a positive impact on our bottom line the way SCORE does. We believe that these programs and their emphasis on best practices provide a priceless return on investment.”

Steven Spradlin
Capital Structures, Inc.
SCORE Elite

SCORE Elite

Capital Structures

capstructures.com
Fort Smith, AR

ProBuild Manufacturing

probuild.com

Anchorage, AK	Albemarle, NC
Big Lake, AK	Berlin, NJ
Chugiak, AK	Albuquerque, NM
Kenai, AK	Delaware, OH
Dolores, CO	Clackamas, OR
Longmont, CO	Mitchell, SD
Lady Lake, FL	Buda, TX
Milton, FL	Carrollton, TX
Plant City, FL	Mercedes, TX
Norcross, GA	Winchester, VA
Pooler, GA	West Point, VA
Hawarden, IA	Arlington, WA
New Hampton, IA	West Richland WA
Indianapolis, IN	Spokane, WA
Valley Center, KS	De Pere, WI
Wadena, MN	

Shelter Systems Limited

sheltersystems.com
Westminster, MD

Sun State Components of Nevada, Inc.

sunstatenv.com
North Las Vegas, NV

SCORE Leaders

Dakota Craft Truss

dakotacraft.com
Rapid City, SD

Millard Lumber

millardlumber.com
Waverly, NE

Plum Building Systems, LLC

plumbuildingsystemsinc.com
West Des Moines, IA

True House, Inc.

truehouse.com
Jacksonville, FL

SCORE Achievers

Allensville Planing Mill

apm-inc.net
Allensville, PA

Latco Structural Components

latcoinc.com
Lincoln, AR

Truss Systems, Inc.

trussystemsinc.com
Oxford, GA



Set your company apart with SCORE's certification program that incorporates all of SBCA's education and training programs – helping you implement cost-effective industry best practices. Learn more about options and how to get started at sbcindustry.com/score.php.

INTRODUCING

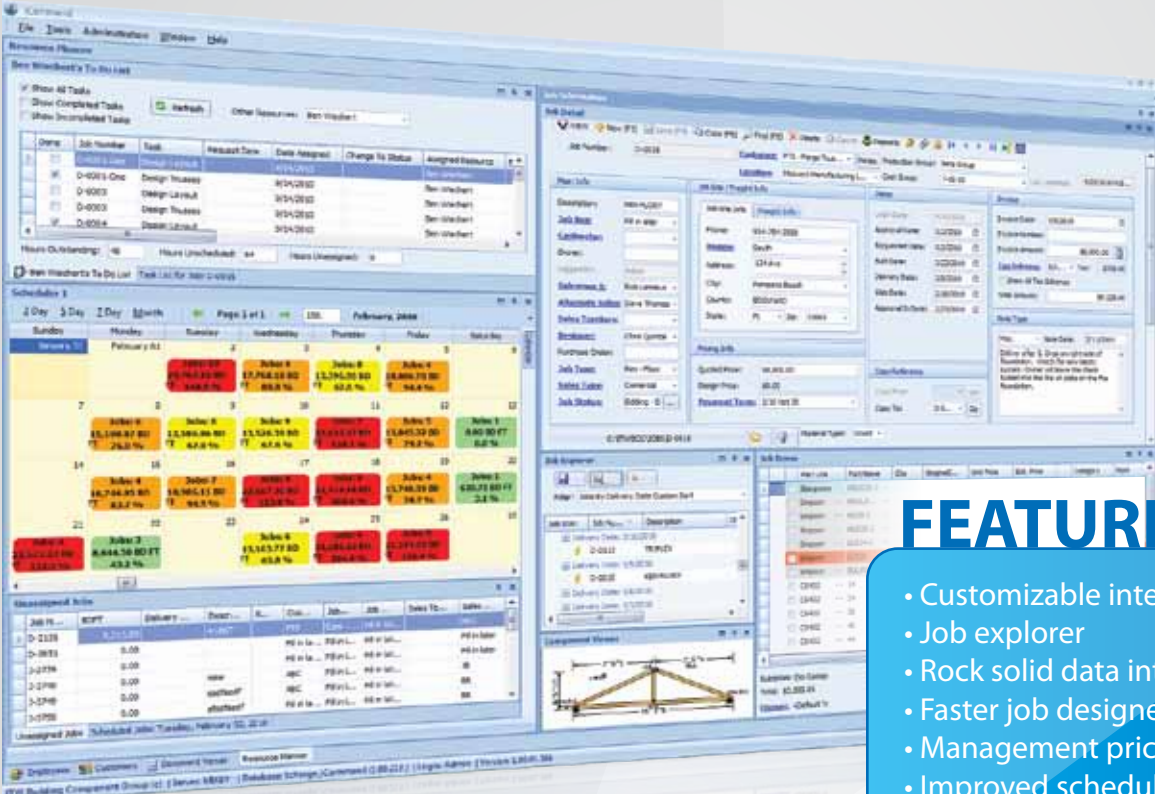

FEATURES

- Customizable interface
- Job explorer
- Rock solid data integrity
- Faster job designer times
- Management pricing
- Improved scheduler
- Resource planner
- Audit logs
- Zip code database
- Quote track
- Materials management system



iCommand is the component industry's most advanced business management application. Built expressly to manage and control the flow of data in your business, iCommand works seamlessly with intelliVIEW.

iCommand starts up automatically and makes capturing critical data easy! That's just the start, iCommand's real value comes from its flexibility in reporting data exactly the way you need it to run your business.

Contact your ITW Building Components Group representative today to experience the industry's most powerful business management software - iCommand.

Instinct is a residential BIM-based system that integrates information and functions through a single 3D model utilized by the entire supply chain.



iCommand and intelliVIEW are part of the Instinct process!

iCommand2Go gives you and your team real-time access to job data, bidding numbers, production status and more on your web enabled mobile device! The latest edition adds the ability to view layouts, engineered drawings, and printed reports in PDF format.

Sign up for your free account: itwbcg.com/icommand2go

SCAN ME!



ITW Building Components Group

www.itwbcg.com / 800.521.9790

For reader service, go to www.sbcmag.info/itw