

Basic Building Structural System

Installation Guide

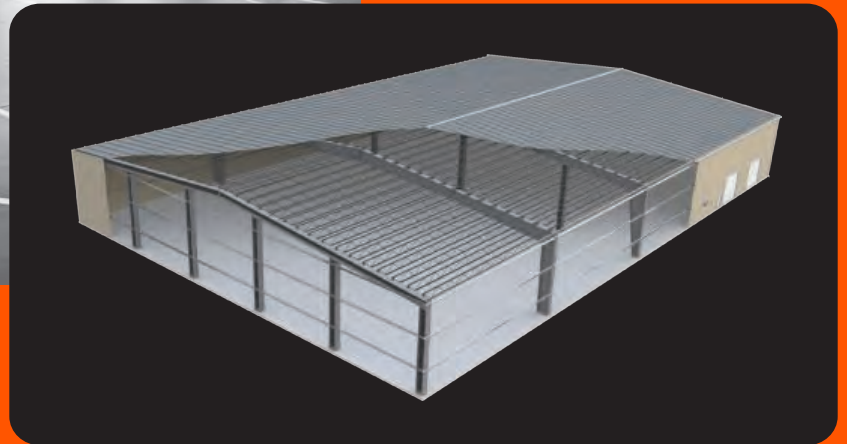



WARNING

You may fall from roof and be killed or seriously injured



Any panel can collapse.

Do not step on panels with creased edges

Do not step on or NEAR edge of panel.

Do not step within 5 feet of panel end.



Panels are slippery.

Use fall protection.



Loose panels may slide out from under you.

Do not step on loose panels or stacks of panels.

Always use fall protection.

Get and read "Roofing Work Safety Instructions" from supervisor.

INDEX

SECTION

TOPIC

A	SAFETY & REGULATORY _____
B	BUILDING DELIVERY AND STORAGE _____ <ul style="list-style-type: none">• Shortages and Damages _____• Materials Unloading and Handling _____• Jobsite Storage _____
C	GENERAL INSTRUCTIONS _____ <ul style="list-style-type: none">• Tools and Equipment _____• Do's and Don'ts _____
D	SCREW INSTALLATION _____
E	FIELD BOLTING _____ <ul style="list-style-type: none">• Bolt Tightening _____• Gaps in Joints _____• Shimming _____• Snug-Tight Joints _____• Pretension Joints and Calibration _____• Tightening Methods _____<ul style="list-style-type: none">◦ Turn-of-Nut Method _____◦ Calibrated Wrench Method _____◦ Tension Control Bolt Method _____◦ Direct Tension Indicator Washer Method _____• Inspection _____
F	FOUNDATIONS AND ANCHOR RODS _____
G	PRIMARY FRAMING _____ <ul style="list-style-type: none">• Erection Procedure _____• Lifting _____• Temporary Bracing _____• Squaring, Plumbing, and Tolerances _____• Column Base Shimming _____
H	SECONDARY FRAMING _____ <ul style="list-style-type: none">• Erection Procedure and Tolerances _____<ul style="list-style-type: none">◦ Cold-Form Members _____◦ Truss Purlins _____
I	ROD BRACING ASSEMBLY _____
J	CRANE SUPPORT _____ <ul style="list-style-type: none">• Runway Alignment _____• Shimming _____
K	FIELD WELDING _____ <ul style="list-style-type: none">• Weld Procedure _____• Welding Thru Coating _____• Inspection _____



INTRODUCTION

All materials, components and accessories sold to Builders are provided subject to written agreements. Any applicable warranties are as set forth in those written agreements. **EXCEPT AS PROVIDED IN THOSE WRITTEN AGREEMENTS, BLUESCOPE BUILDINGS NORTH AMERICA, INC. COMPANIES MAKES NO WARRANTIES, EXPRESSED OR IMPLIED, INCLUDING THE WARRANTIES OF MERCHANT ABILITY AND FITNESS FOR A PARTICULAR PURPOSE.**

The Erection Guide is intended to provide erectors with the recommended procedures for constructing buildings as efficiently as possible. However, BlueScope Buildings North America, Inc. does not guarantee and is not liable for the quality of erection nor assume any responsibility for building defects that may be attributed to improper erection techniques, or the negligence of other parties.

The erection information presented in this manual is provided as a supplement to the erection drawings supplied with your Building.

The manual is intended as a guide to be used in conjunction with your erection drawings, to help plan and organize your work. It will help you to identify parts, establish an erection sequence, speed up assembly and point out any areas or procedures requiring special emphasis or attention.

Where erection drawings and this guide are in conflict, the job specific erection drawings govern. Read all erection instructions before erecting the building.

Supplemental Erection Guides are required for Roof And Wall Panels and other building accessories. Always refer to erection drawings for building specific details.

Refer to the Metal Buildings Manufacturers Association's Metal Building Systems Manual for more details on common industry practices and Glossary of Terms. In Canada, See Canadian Sheet Steel Building Institute for guidelines.

BlueScope Buildings North America, Inc. reserves the right to change at any time products and/or procedures illustrated in this guide due to continuing product development.

SAFETY FIRST

Job site safety is the sole responsibility of the contractors . Contractors are responsible for FULL compliance with all governing regulatory agency's safety requirements for your specific construction site including but not limited to Federal, State, Provincial, and local agencies having jurisdiction over your job site. Governmental regulations on construction safety are available from any government book store. The Contractor is also solely responsible for compliance with all owner specified safety requirements at the job site.

Identification of safety regulatory agency requirements for construction related procedures is beyond the intent of this installation guide. Any action required from BlueScope Buildings North America companies regarding safety issues shall be specifically identified in the contract documents.

Roof Panels / Roof Safety



WARNING: You may fall from roof and be killed or seriously injured.

Working off the ground even a few feet can be extremely dangerous. Falls from height of six feet or less can be fatal. You should be aware of the hazards while installing roof panels.

I. PANELS CAN COLLAPSE



Roof panels can be a safe walking surface (except for slipperiness) ONLY when they are completely seamed or fastened as applicable. Panels not completely seamed or fastened are not safe and can collapse suddenly and without warning.

SAFETY FIRST

When installing roof panels, always use fall protection. Follow these additional safety precautions:

1. Never step, kneel or place weight on an edge or edge corrugations of any panel.
2. Use extra care when installing panels with creased or kinked corrugation or edges. Placing weight on any portion of such a panel before it is completely installed may cause the panel to collapse.
3. Never stand or work within five (5) feet from the end of a panel that is not completely seamed or fastened.
4. Before a panel is completely installed, always stand, kneel or work directly over the roof structural.
5. Never allow more than one worker to stand, kneel or work on the same panel between two roof structurals before the panel is completely installed.
6. When walking on roof system liner panel that has been completely fastened to the roof structural, do not step on the sidelap. Step only on the liner panel area that is directly over the roof structural.

Never use unattached roof panels as a work platform for any purpose. This is an extremely hazardous practice and should never be done.

II. PANELS ARE SLIPPERY



All roof panels, whether painted or unpainted, are slippery to walk on. Dew, frost, or any other moisture on roof panels greatly increases the slipperiness of the panels and extra care should be taken. The pitch of the roof can also increase the hazard.

Because of these hazardous conditions, it is essential that fall protection be used at all times.

SAFETY FIRST

III. LOOSE PANELS MAY SLIDE OUT FROM UNDER YOU

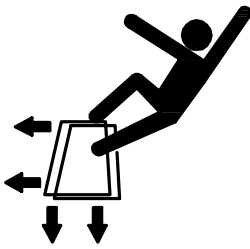

Never step on a single roof panel or a stack of several roof panels lying unattached on the roof structurals. If you step onto a single panel on the roof structurals, it may slip causing you to lose your balance and fall. Even a stack of several panels on the roof structurals may slip if you step on it.

WHAT TO DO TO PREVENT ROOF FALLS

1. Always Use Fall Protection - including but not limited to, lifelines, safety harnesses, lanyards, safety nets, scaffolding, man-lifts, catch platforms, and the Sky-Web systems.
2. If You Need a Work Platform - for laying insulation or any other purpose, use only platforms constructed in accordance with all safety regulations. Never use unattached or partially attached panels as a work platform.
3. To Avoid Slipping - wear good work boots while on the roof. The danger from a slip is greatest while installing roof panels or insulation at the edge of the roof. Use walkboards in the flat of panels when installing panels. When working near the edge of the roof, always use fall protection.
4. To Prevent Panels from Slipping - Do not step on loose roof panels or even a stack of several roof panels.
5. Walkboards - One method to add stability to panels during erection is to place walkboards in the flat of panels. The boards should run the full length of the roof slope and should be fastened together by drilling a hole near the ends of each board and tying it to the next board with rope. Cut a groove in the bottom of each board so that the board will lie flat and not tip back and forth because of the rope. This will prevent the boards from slipping out from under you when you step on them. Adequately secure walkboards to the building. Walkboards are not a substitute for appropriate fall protection.

BUILDING DELIVERY

- Before the building arrives, make sure space is available to store and inventory the components.
- Check off all primary framing members with manifest and erection drawings.
- Check for quantity of boxes and or crates called for on the manifest.
- Check for purlin or girt bundles as called for on the manifest.
- Check for visible damage.
- Ensure that all wet components have been dried before storing.
- Store all components so that there is no collecting of water in bundles or frames.
- Do not cover tightly. Leave room for air circulation around bundles.
- Store warehouse items in a dry, secure location (i.e. doors, windows, fasteners and mastic).

As the building is shaken out, check all individual boxes, bundles and crates for any damages or shortages. This will help eliminate lost time waiting for replacement materials.

Shortages & Damages

- A complete inspection should be made at time of delivery.
- The receiver should "conditionally" sign delivery receipt if there is any evidence of damage. Notation must be made on the delivery receipt accordingly. A detailed note of the damage, a date and a signature must be made on the delivery receipt. Do not offer opinion as to how you think the product was damaged. Opinions could affect your claim.
- Any items in crates or boxes that are concealed must be inspected. Failure to inspect and make note of any damage immediately on the delivery receipt could result in the receiver being responsible for any damage found later.
- The carrier should be immediately notified that shipment is damaged and request to send a representative to inspect and verify damage. If you would like assistance please contact your Project Manager immediately. Also, a copy of the inspection report should be requested.
- Take at least six pictures of damaged material, one from each side of the trailer and of the front and rear. Take picture of carrier trailer number. Take picture of damaged part numbers and make note of part numbers on delivery receipt.

Shortages & Damages Cont'd

- A claim should be filed with the carrier as soon as possible, sending with it the original Bill of Lading, original paid freight bill, copy of the inspection report, disposition of damaged material and amount of claim. BlueScope can assist you with filing the claim with the carrier.
- Do not dispose of damaged material. Damaged material must be saved for the carrier to salvage. Failure to do so may affect your claim.
- Concealed damage should be reported within (15) days of delivery.
- Shortages of primary and secondary framing must be reported within (5) working days.
- Shortages of any other materials must be reported within (10) working days.

NOTE: It is the responsibility of the Builder/Erector to check for damaged material and shortages. Damages **MUST** be noted on delivery receipts and your Project Manager notified as soon as possible.

MATERIALS UNLOADING AND HANDLING

ARRIVAL AT THE BUILDING SITE

In winter conditions, immediate power washing of steel that has been exposed to road salt or chemicals during transit should be done.

UNLOADING AND MATERIAL LAYOUT EXAMPLE

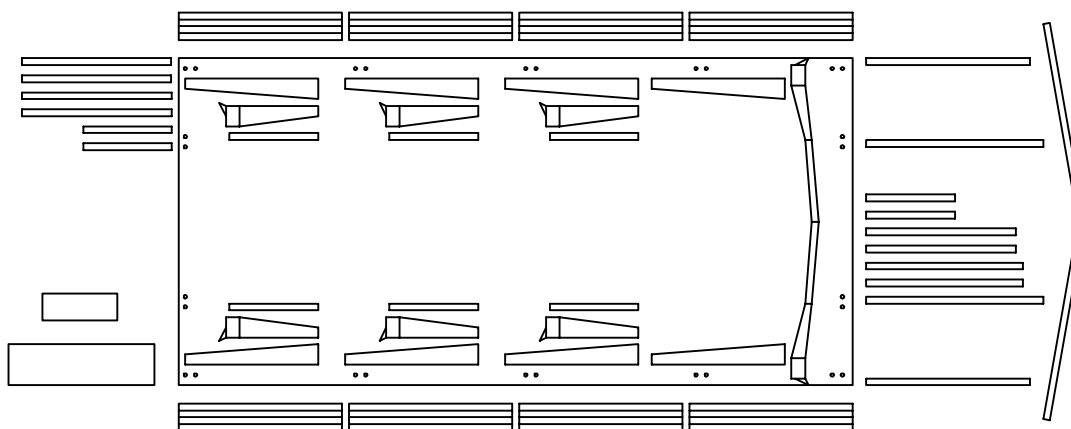

NOTE:

Leave an access area through one end and the full length of the building for erection equipment. When unloading use appropriate equipment to avoid damage.

FORKLIFTS

Extreme care should be taken to avoid damage from fork blades. The erector is responsible to have proper equipment available at the jobsite. When lifting products, make sure forks are spaced wide enough to provide stable handling of parts, bundles and crates.

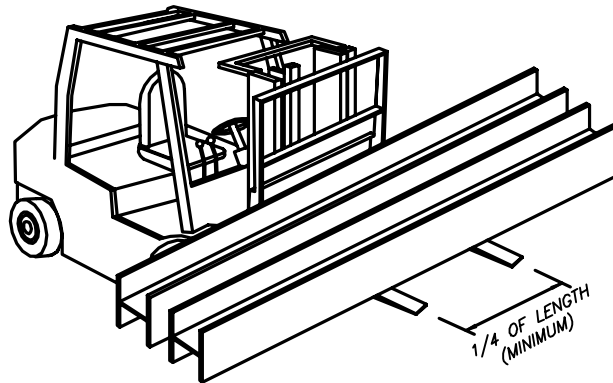

When handling long crates or bundles (>20 ft) spreader beam should be bolted to forks so that slings can be used to widen pick points.

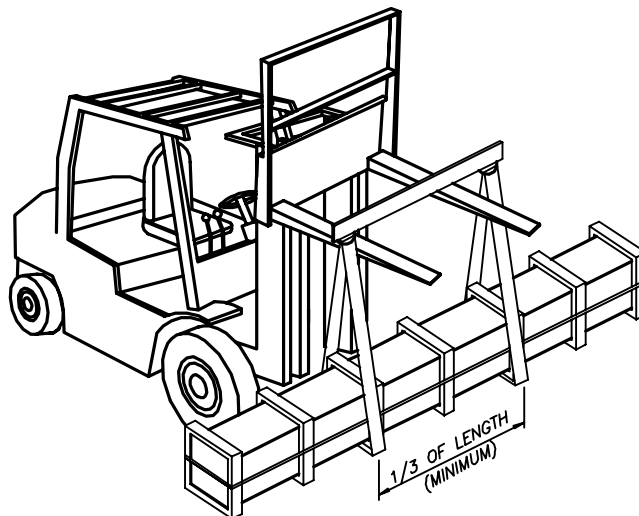

SLINGS (CRANES OR FORKLIFTS)

Lifting of the "INDIVIDUAL BUNDLES" should be by spreader bars and nylon slings (or similar material) located at a minimum of two points along the length of the bundle. Suitably stiff inserts should be located at the top and bottom of the bundles at the sling positions to protect the edges of the panels and crates.

Balance load so material will not slide.

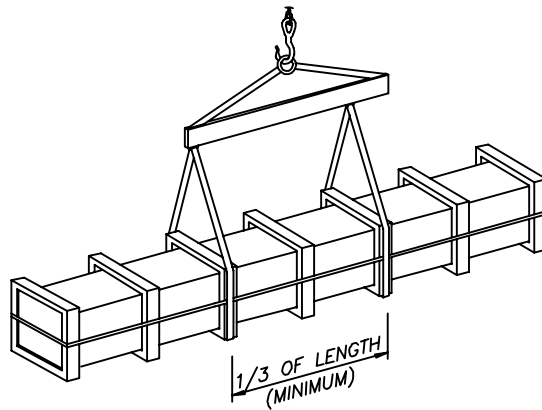

Extreme care should be taken to avoid bumping and snagging of the bundles when lifting.

Rigging is the responsibility of the erection crew. It is recommended that the erector review OSHA 1910.184 for rigging considerations.

Per OSHA 1910.184(c)(7), 'Slings shall be padded or protected from the sharp edges of their loads.'

TRUSS/BUNDLE UNLOADING AND HANDLING

When unloading and handling long span secondary trusses or bar joists, always lift purlins/joists and bundles in vertical position.

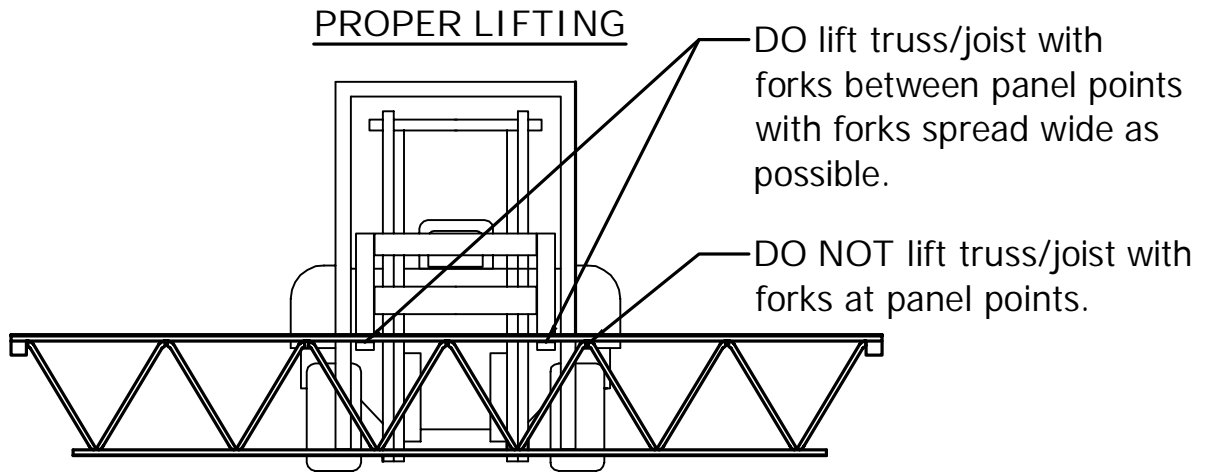

IMPROPER LIFTING

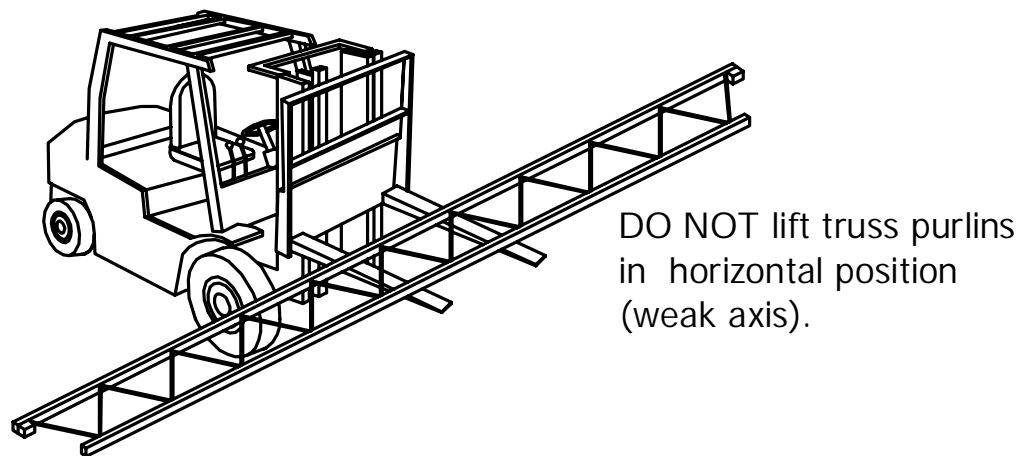

HAND UNLOADING AND CARRYING

When carrying panels by hand, always lift from bundle, never drag.

Gloves should always be worn when handling panels.

MATERIAL HANDLING OF PANELS

A. Carry panels on edge in a vertical position for stiffness

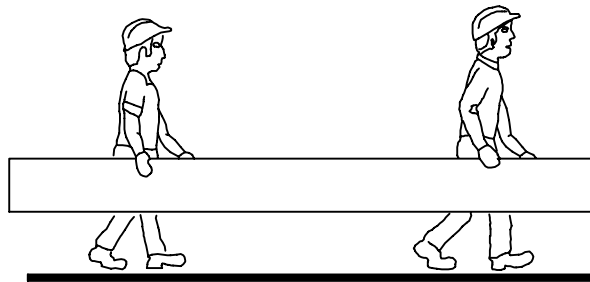

B. Picking up panels at ends and rotating in propeller shape will cause damage.

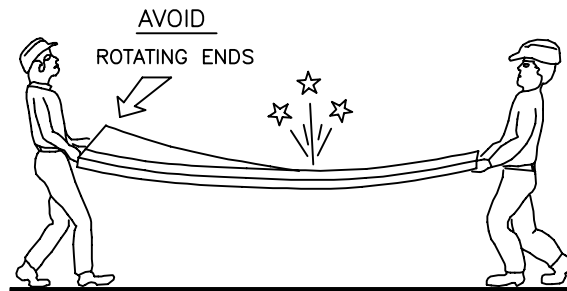
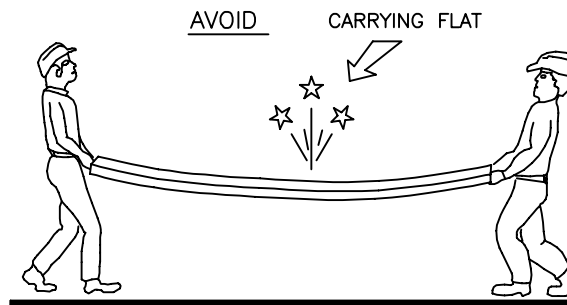

JOB SITE STORAGE & PROTECTION

PANELS AND TRIMS FOR IMMEDIATE USE

If the panels are to be used immediately, the bundle should be placed at pre-planned strategic locations around the perimeter of the building as close as possible to the planned work areas. Consult the panel layout drawings to determine these locations. As far as practical, the bundles should be placed as close to installation area as possible to avoid later site maneuvering or undue handling.

Protect opened bundles with polyethylene cover (or similar material) when erection stops at end of the day. If panels are crated, replace the lid of the crate before covering.

Bundles for panels which are shipped on edge should be kept in upright position during storage and unloading. Block up edge of bundle with 2" x 4" blocking to keep panels from slipping. DO NOT stack material on opened bundles.

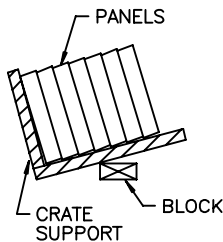

NOTE:

Moisture trapped within panel bundles can cause the finish to soften and become more susceptible to erection handling damage. Panels stored wet, or for extended periods in humid conditions will oxidize (rust).

Panels and trims MUST be kept dry. If panels arrive wet or become wet at the jobsite, break open bundles and allow to dry completely.

PANELS AND TRIMS NOT FOR IMMEDIATE USE

If panels/trims are not required for immediate use, they should be carefully stored in a designated area, under cover.

Store bundles to allow for drainage. Wood blocking to elevate one end of bundle is recommended.

Bundles should be stacked no more than two high with any bearers of the upper bundles in line with the bearers of the lower bundle. Where bearers do not align, place 2" x 6" wood planks longitudinally between the two bundles to help distribute the load.

Provide for ventilation of bundles if conditions are such that condensation may occur. Protective shrink wrap material on bundles should either be slit or loosened.

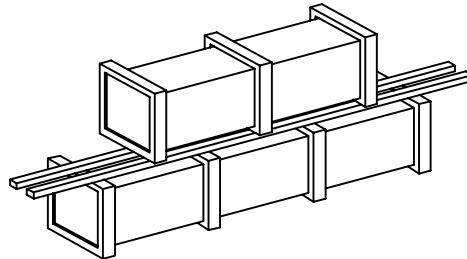
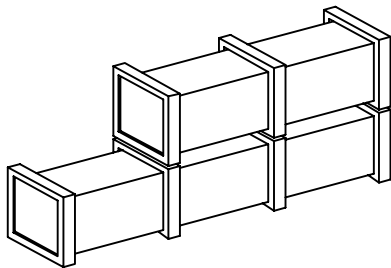

TRIMS, AND SMALL PARTS IN CARDBOARD CARTONS

Due care should be afforded to the unloading and storage of trims and small items (fasteners, sealants, etc.) that arrive on site for inclusion in the work.

Trim items are normally shipped in cartons which must not be allowed to get wet. Use 2" x 4" blocking spaced no more than 3'-0" o.c. under cartons. Keep cartons square to prevent bending trim items.

Cover exposed cartons with polyethylene or equal. Leave ends open to provide air circulation.

Do not open cartons until ready for use. Protect loose material from damage.

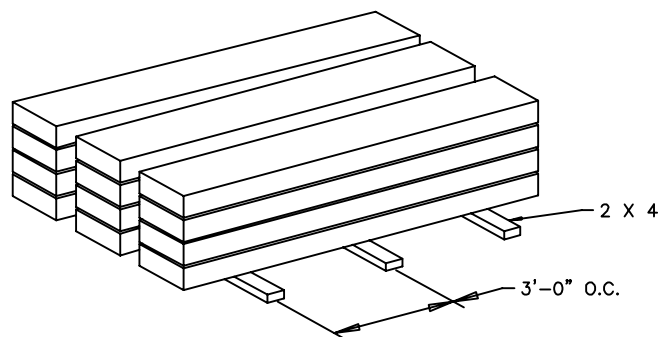

Cardboard cartons and contents must be kept dry. If cartons arrive wet or become wet at the jobsite, break open cartons and allow contents to dry completely.

GENERAL INSTRUCTIONS

RECOMMENDED ERECTION TOOLS & EQUIPMENT

The following list of tools and equipment should be considered for efficient building erection. This equipment may vary from area to area due to variations in building proportions, complexities, jobsite conditions and erection personnel. This list is intended to serve as a recommendation only and should not be interpreted as a limitation to your erection equipment. The builder is responsible for providing equipment commensurate with the type of building being erected. Safety Equipment must meet regulatory requirements.

- Electric screw guns with magnetic heads (Recommend 2000 RPM with depth sensing nose piece or adjustable clutch).
- Electric sheet metal nibbler and shears for cutting sheeting on job site. Keep replacement cutting bits in stock.
- Arc welding equipment with extra welding leads for welding (portable).
- Bolt Tension Calibrator; (such as Skidmore-Wilhelm)
- Extension ladders (at least two that are long enough for high buildings).
- One (1) set of torches with gauges and hoses for cutting (keep replacement tips in stock).
- Steel tapes for checking measurements (100', 50', and several 12'). Stretch tape for measuring along rakes.
- At least one (1) 4' level.
- Sheet metal cutters (straight, left, and right cut).
- Sufficient amount of suitable cable for temporary bracing.
- One (1) power impact wrench with assortment of impact sockets.
- Appropriate number of chokers and rope for use when the crane arrives for raising structural steel.
- At least one (1) ratchet and wrench set (heavy duty) with appropriate extensions and attachments.

- Plenty of electrical extension cords for all tools used at one time.
- Shop and sledge hammers.
- Spud wrenches.
- Wrecking bars and heavy duty drift pins.
- Skill saw with metal cutting blades and carbide tip blade.
- Hack saws.
- Framing square and tri-squares.
- Transit and level rod.
- Vise grips (assortment of types).
- Crescent wrenches (heavy duty).
- Box end and open end wrenches (assortment).
- Razor knives.
- Straight line string.
- Chalk boxes with replacement line and chalk.
- Caulking guns for sausage pack and cartridge sealants.
- Ample supply of pop rivet tools, both manual and electric powered.
- Staple pliers for stapling insulation and ample supply of replacement staples.
- $\frac{3}{8}$ " and $\frac{1}{2}$ " drive electric drill and appropriate twist drills.
- Acetone cleaners and rags.
- Brooms.
- Approved safety devices.

DO'S & DON'TS

Job Information

- "For construction" drawings must be the only drawings at the jobsite.
- Erection guides are sent to every Builder's office and with each building. Be sure at least one copy is on each jobsite.

Jobsite Inventory

- Always inventory building components as they arrive but not more than 2 weeks after delivery. This will avoid lost time waiting for replacement.
- Immediately report shortages and damaged materials to your project manager.
- Inventory and store all warehouse items in a dry and secure location. Only take out bolts, fasteners, mastic, etc. that will be used each day.

Temporary Bracing

- It is the responsibility of the erector to design and provide for all temporary bracing. This includes size, type, location, and quantity.
- **Never** begin erecting a building without having temporary bracing on site along with a plan for installing and securing it.
- As erection progresses, all brace rods, flange braces, struts, purlin/girt laps should be installed prior to panel installation.
- All building components will require temporary bracing during erection. Do not remove temporary bracing until after wall and roof coverings are installed.

Flange Braces

- All flange braces must be installed per the erection drawings.
- **Never** remove, relocate or omit a flange brace. If holes were omitted in manufacturing, it is the responsibility of the erector to insure that all flange braces called for on the erection drawings have been installed.
- If a flange brace is called for at a location which will interfere with a window, overhead door, or other required accessory, contact project manager for written directions.
- Flange braces are required even when you have liner panels. See erection drawings.
- See erection drawings for bolting requirements of flange braces to frames and secondary member.
- Never substitute self-drilling fasteners for bolts unless approved by engineering.

Brace Rods

- Always tighten rods as snug as possible. Reduce rod sag as much as possible without creating distress in the connection to framing members. Matching rods should always be equally tensioned in each bay.
- **Never** remove or omit a brace rod.
- **Never** relocate any brace rods. If relocation is necessary due to interference with doors, openings etc., contact project manager for written direction and authorization.

Erection Tolerances

- Erection tolerances shall be as given in the AISC code of Standard Practice Section 7, unless specified otherwise in this manual, or on erection drawings.
- Shimming and plumbing are the responsibility of the erector and shall be done in accordance with this manual.

Connection Bolts

- Use correct bolt length and type called for on the erection drawings or erection drawing details.
- Install correct quantity of bolts called for on frame cross sections or specific details.
- Insure that all high strength bolts are properly tightened. See drawings for direction if bolts require "pre-tension" or snug tight". See Section E - Field Bolting for more details.
- **Never** use a A307 bolt and nut where A325 bolts are called for.

Purlin or Girt Installation

- All purlin/girt lap bolts are to be installed in the outermost set of holes.
- Pull all lap conditions up tight, sometimes reversing the lap will allow the purlins to nest better. A little time spent on making a tightly nested lap will pay off when installing wall and roof panels.
- Always block up wall girts to insure straightness.
- Never load purlins at mid bay. Keep all loading directly over the frames. DO NOT overload roof secondary members.
- When loading roofing bundles on to the roof purlins, always block the purlins to prevent crushing and rolling.

Cutting & Burning

- **Never** use a torch to "field drill" structural connection holes. Holes must be drilled or "burned & reamed". If a torch is used in any component to make a hole, burn a small "pilot hole", then ream to achieve smooth hole of proper size.
- If field cutting of members is done with a torch, grind edges smooth and touch up with primer or zinc rich paint.
- Never modify, cut, cope, or add holes in members unless authorized by an engineer or as specified on erection drawings.

SCREW INSTALLATION

Proper installation of screws is critical to the strength and performance of the structure. The erector is responsible for furnishing proper screw guns, correct sized drivers, and applying proper technique when installing screws. Failure to do so will result in improper seating of the screws which will cause leaks, or heads breaking of screws, or excessive burnout of drill tips.

SELF-DRILLING SCREWS (SDS) and SELF-TAPPING SCREWS (STS)

Installation tool for SDS's and STS's must be an electric screw gun with features as follows to obtain optimum fastener installation.

- Minimum 6-amp power
- Variable speed (0 - 2000 RPM no load). DO NOT use high speed screw guns > 2500 RPM.
- Depth sensing nose piece or adjustable clutch for torque control.
- Use proper size magnetic drive bits for the type screw used. Discard and replace worn out drive bits as they will damage the screw head.
- Keep steel filings from collecting in magnetic drive socket cavity or screw heads will not properly seat.

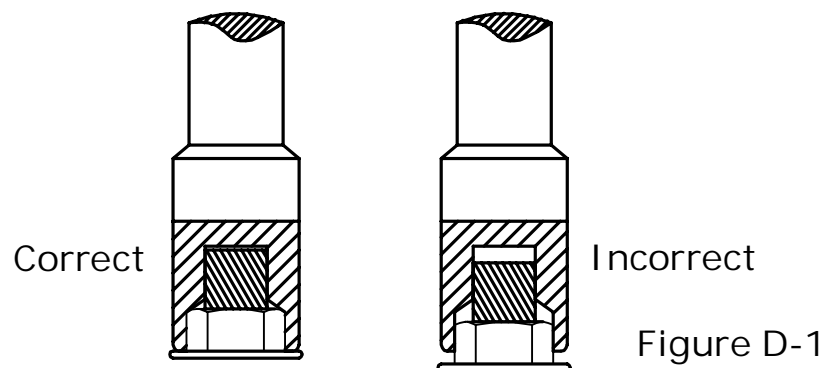

- DO NOT use impact drivers when installing SDS's or STS's. Screws will be overdriven and will break off during or after installation.

Screws with sealing washers must be carefully installed so the flexible sealing washer is properly seated for weathertightness. ALL drill filings must be removed from steel surfaces or rusting will occur.

DO NOT OVERDRIVE!

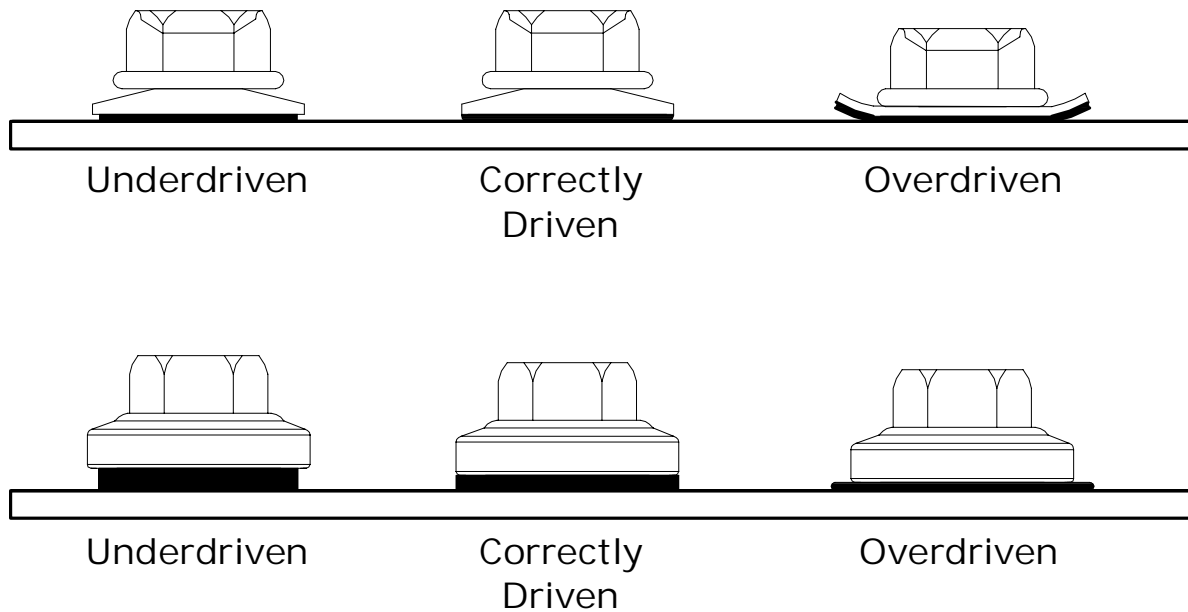

Figure D-2

Screws without sealing washers should be "seated snug" such that the head is flush with the steel surface. DO NOT overdrive. Excessive tension and torque on the screw will result in the heads breaking off during or after installation (hours or days later).

Screw length must be sufficient to penetrate all connected material.

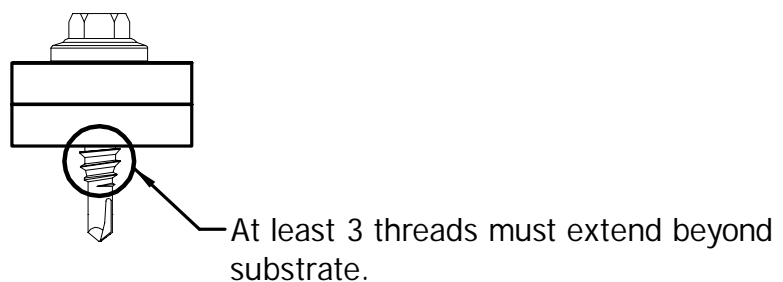

Figure D-3

AVOID tip burn out. Drilling speeds must be set to proper speed for the type of drill tip used. Apply steady uniform pressure during drilling.

Table D-1

Drill Point Type	Maximum RPM	Material Thickness Range (Total t)
DP-1	2000	0.018" - 0.095"
DP-2 & 3	1800	0.036" - 0.175"
DP-4	1800	0.125" - 0.250"
DP-4.5	1800	0.125" - 0.375"
DP-5	1800	0.125" - 0.500"
Self-Tapping Screws	1000	NA

Improperly installed screws must be removed and replaced.

SCRUBOLTS

Installation tool for scrubolts must be a 1/2" electric impact wrench. A 5" long drive extension and magnetic sockets as required for specific size screws used. Scrubolts require a pilot hole since they are not self-drilling.

Scrubolts with flexible sealing washers should be tightened as shown in Fig. D-2. DO NOT overdrive.

Scrubolts without washers should be "seated snug" such that the head is flush with the steel surface. DO NOT overdrive.

FIELD BOLTING

Field bolted joints must be installed in strict compliance with BBNA erection drawings, the Research Council on Structural Connections Specification for Structural Joints Using High-Strength Bolts, and the instructions in this guide. Bolted joints are designated as "snug-tight" or "pre-tension". General tightening requirements are as follows unless specified otherwise on the erection drawings.

All connections to purlins, girts, truss purlins, bar joists, flange braces, bracing struts, and primary framing may be installed to the snug-tight condition except as follows. High strength bolts must be pre-tensioned when:

- Any connection using A490 bolts.
- Connections in frames supporting cranes >5 tons capacity.
- In framing supporting machinery that creates vibration, impact, or stress reversals on connections.
- In frames and bracing of buildings located in high seismic areas. See erection drawings for seismic category.
- In any connection designated as slip critical (A325-SC). In addition, connections must be bare steel with primer, oils, dirt, and heavy rust removed from the contact areas. Galvanized or lightly rusted surfaces are permitted. Erector is responsible to ensure contact areas are clean and free of primer.

Joints designated with threads excluded from shear plane (A325-X and A490-X) shall be installed with bolt head against the thinnest plate.

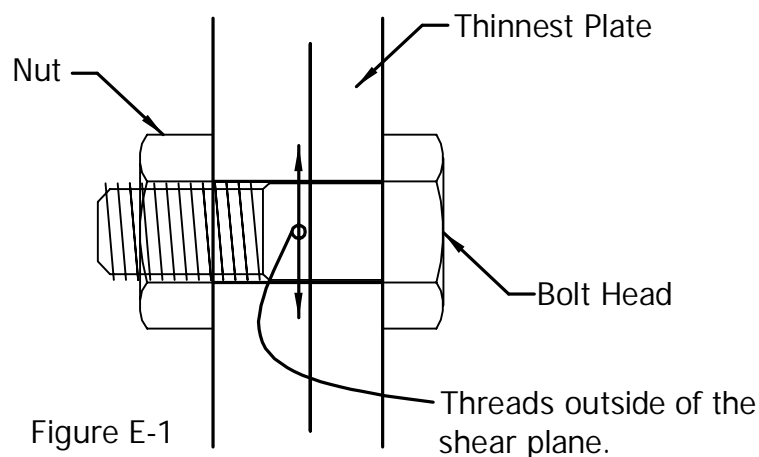

Figure E-1

SYSTEMATIC TIGHTENING

All bolts in a connection must be loosely installed before tightening. Bolts should be snug tightened starting at the most "rigid" part of the joint working toward the free end or less rigid end until plies are in contact (Figure E-2). If pre-tensioning is required, further tighten bolts in the same order.

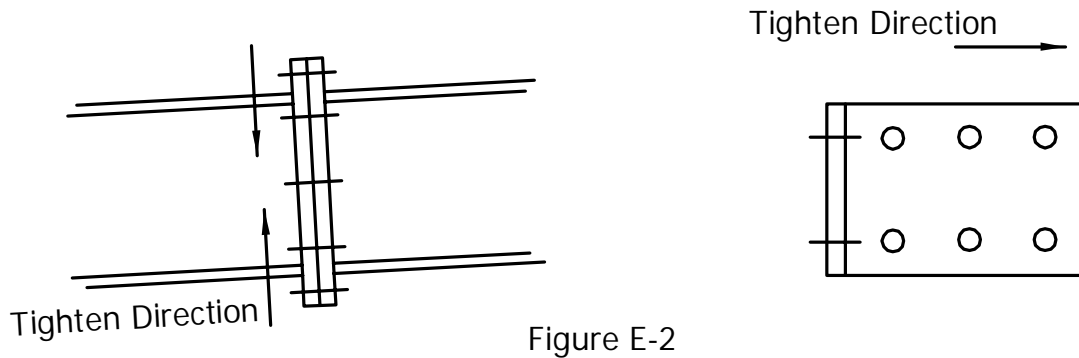

Figure E-2

- Bolts that have been snug-tightened may be removed and reused. Bolts that have been pre-tensioned are NOT permitted to be reused unless approved by engineering.
- After installation and tightening, the bolt end must be at least flush with the face of the nut. If the bolt end is below the face of the nut, remove the bolt and install a longer one. There is no "maximum" stickout limit

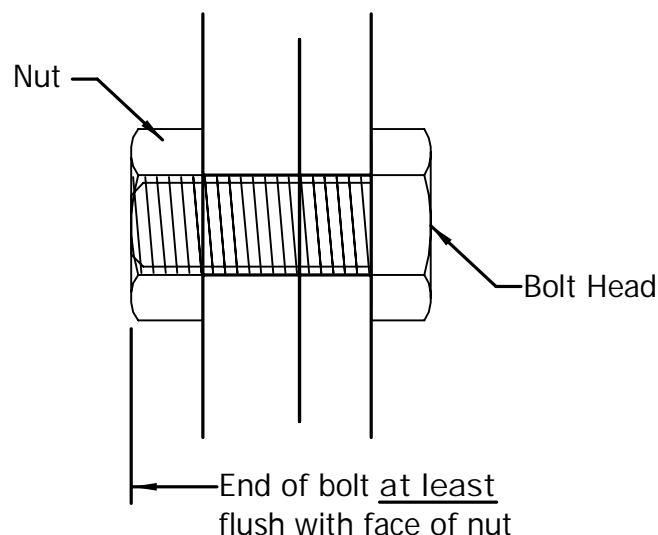

Figure E-3

GAPS IN JOINTS

Connected parts shall be installed as permitted in this section. In primary frame endplate connections distortion due to welding may cause minor gaps that cannot be brought together even after the bolt is fully tightened. Small gaps are permitted as illustrated below. If gaps larger than indicated below are found, shimming is required.

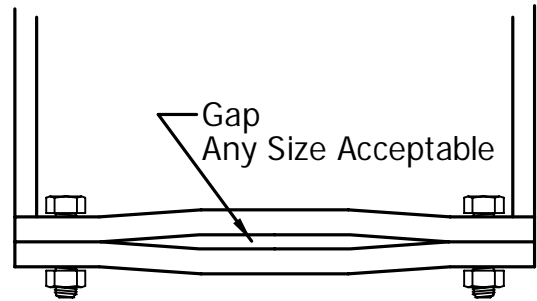
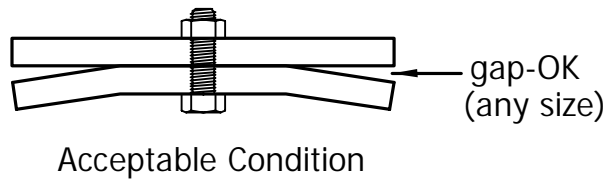

Figure E-4
Acceptable Gaps

Bearing connections and endplate connections. Small gaps are permitted at bolt locations and at flange locations as shown in Fig. E-5.

- Gaps at bolt location are acceptable and need not be shimmed if : $\text{gap} < 1/8"$.
- Gaps at flange location are acceptable and need not be shimmed if: $\text{gap} < 1/16"$.

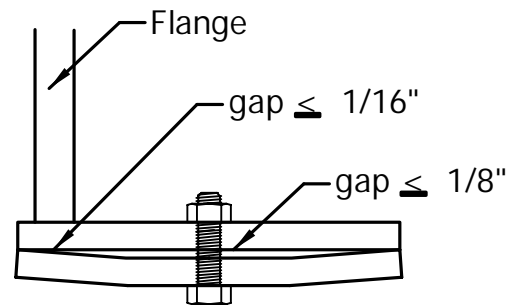

Figure E-5

Slip-critical connections.

Gaps are not permitted at bolt locations. Uncoated surfaces are required to be in firm contact as shown in Fig. E-6. Galvanized surfaces are permitted.

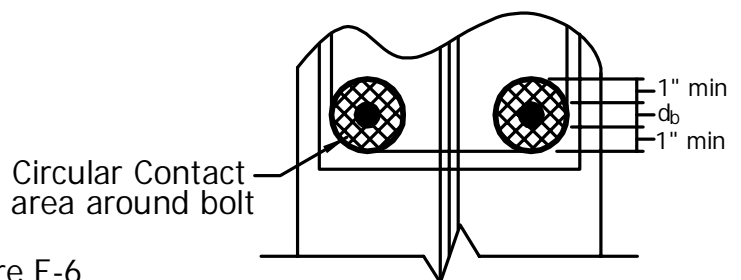
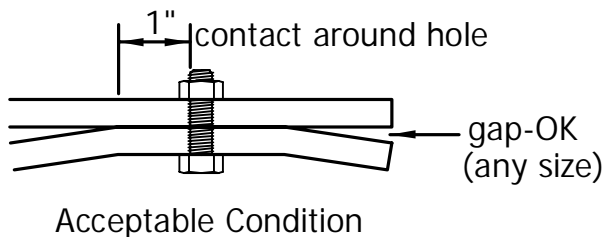

Figure E-6

SHIMS

On occasion shims may be required to fill joint gaps, level beams, accommodate varying depth of members, level frame bases, adjust for differential frame deflection, etc. Some shimming must be anticipated by the erector and is considered by the Code of Standard Practice to be part of the erection contract. Shims are provided by the erector.

Shimming between gaps at flanges is accomplished with thin flat plates stacked between the joints.

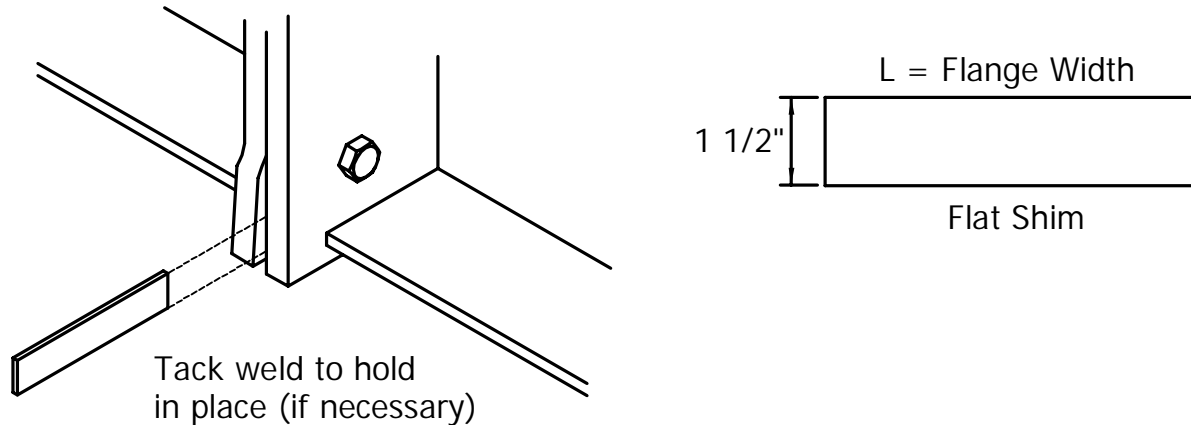

Figure E-7

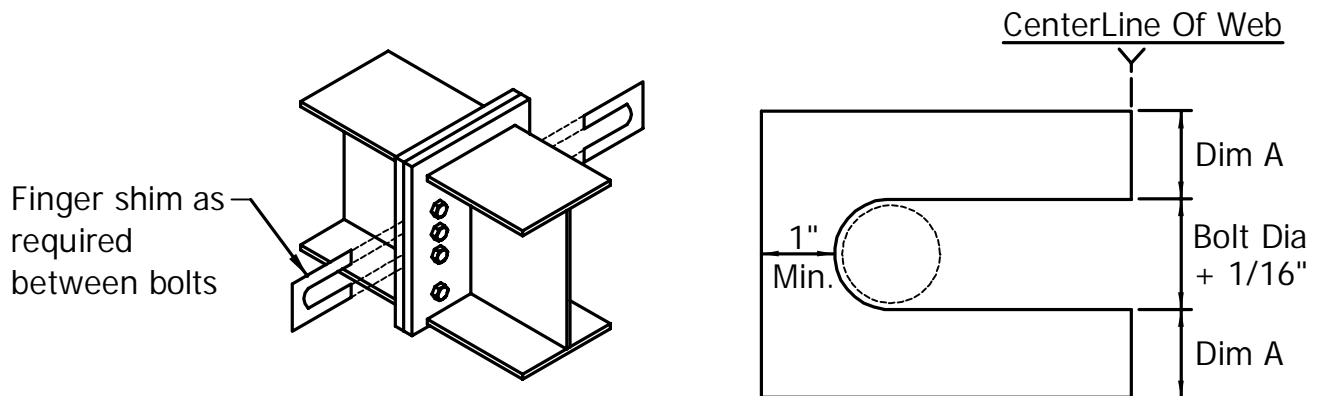
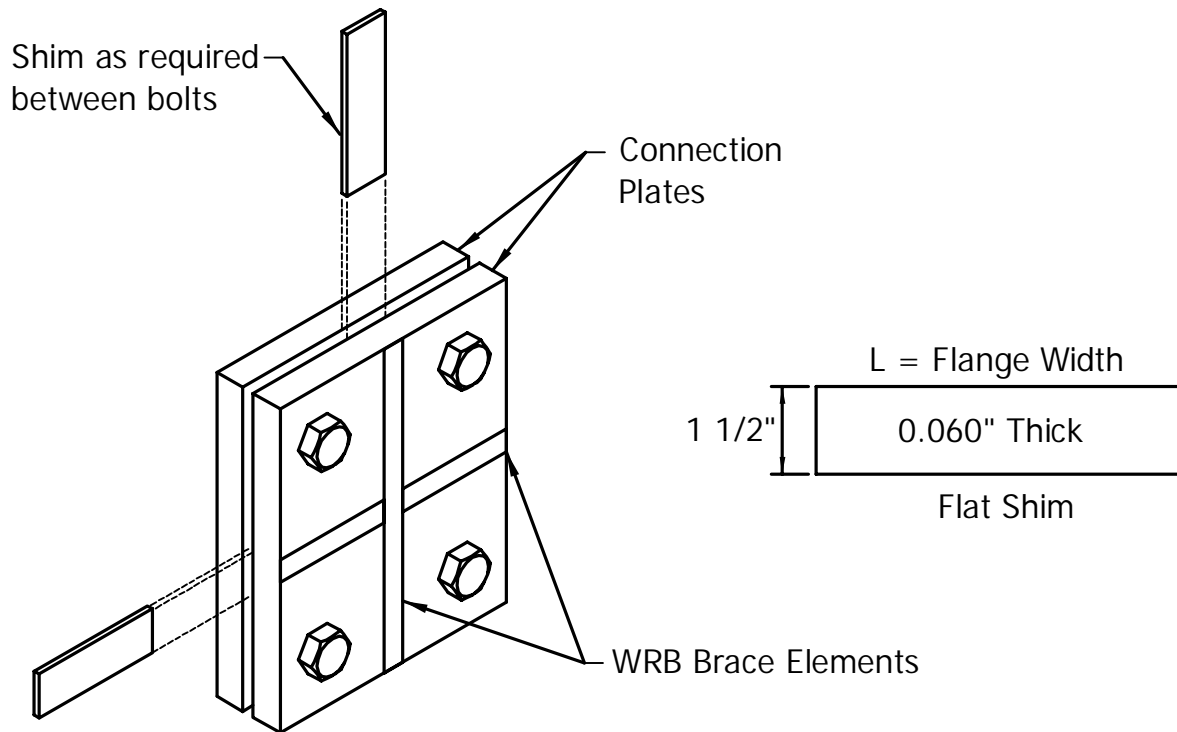

Figure E-8

- Dim A = 1". Shim dimensions may vary from those shown if required for fit up
- Multiple shims may be stacked to fill required gap.
- Gaps greater than a $1/4"$ require engineering review. Contact your Project Manager.

SHIMSFigure E-9

Shim detail for WRB Brace End Connection.

- Align shims with plates and gussets as shown.
- Insert shims as far as possible until tight.
- Tighten Bolts
- Shims may be stacked as required.
- Tack Weld to edge of connection plate to hold in place.

SNUG-TIGHT INSTALLATION

Snug-tight is defined as:

"The tightness that is attained with a few impacts of an impact wrench or the full effort of an ironworker using an ordinary spud wrench to bring the plies into firm contact."

PRETENSION JOINTS

Joints that require pretension must use one of the following tightening methods and all methods must be calibrated for each representative fastener assembly prior to installation.

- Turn-Of-Nut Method
- Calibrated Impact Wrench Method
- Twist Off Type Tension -Control Bolt Method (See manufacturer's instructions)
- Direct Tension Indicator Method (See manufacturer's instructions)

TENSION CALIBRATION

- A hydraulic tension calibrator (e.g. - Skidmore-Wilhelm Bolt Tension Calibrator) shall be used to validate that the tightening method used achieves required bolt tension. (See manufacturer's instructions)
- Take three fastener assemblies of each diameter, length, and grade to validate each assembly to tension values shown in Table E-1.
- Verify that the lubrication of the fastener assembly is similar to condition that will be present when installation work is done .
- Log results for the calibrated assembly.

TABLE E-1 (Reproduced from RCSC Table 7.1 & S16 Table 7)

Minimum Pre-Installation Tension Verification (kips)				
Bolt Diameter (in)	A325 and F1852		A490	
	KIPS	KN	KIPS	KN
1/2"	13	56	16	70
5/8"	20	89	25	112
3/4"	29	131	37	165
7/8"	41	183	51	229
1"	54	238	67	299
1-1/8"	59	261	84	374
1-1/4"	75	332	107	477
1-3/8"	89	397	127	565
1-1/2"	108	481	155	691

PRETENSION JOINTS USING "TURN-OF-NUT" METHOD

1. Complete pre-installation tension calibration.
2. Bring connection to "snug tight" condition. See procedure above.
Turn-of-Nut method does not require washers, unless called for on erection drawings
3. Matchmark each nut, bolt, and steel surface at the corner of the bolt and nut as shown in Figure E-9.
4. Using the same systematic procedure as used during the snugging phase, rotate each nut or bolt head the required turns as shown in Table E-2.
5. These added turns can be accomplished using impact wrenches or spud wrenches.

Figure E-9

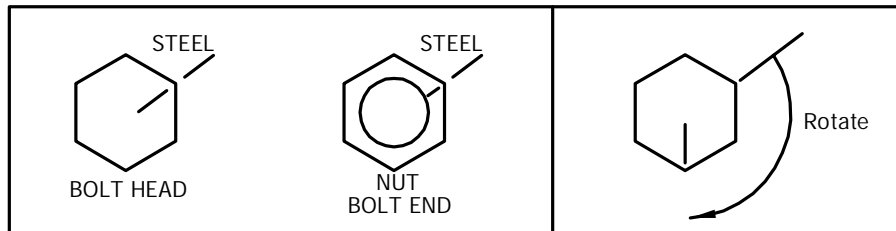

TABLE E-2 (Reproduced from RCSC Table 8.2)

TURN-OF-NUT TIGHTENING TURNS REQUIRED (flat surfaces only)					
Bolt Diam	Length	Turns	Bolt Diam	Length	Turns
1/2"	$L \leq 2"$	1/3	1"	$L \leq 4"$	1/3
	$2" > L \leq 4"$	1/2		$4" > L \leq 8"$	1/2
	$L > 4"$	2/3		$L > 8"$	2/3
5/8"	$L \leq 2\text{-}1/2"$	1/3	1-1/8"	$L \leq 4\text{-}1/2"$	1/3
	$2\text{-}1/2" > L \leq 5"$	1/2		$4\text{-}1/2" > L \leq 9"$	1/2
	$L > 5"$	2/3		$L > 9"$	2/3
3/4"	$L \leq 3"$	1/3	1-1/4"	$L \leq 5"$	1/3
	$3" > L \leq 6"$	1/2		$5" > L \leq 10"$	1/2
	$L > 6"$	2/3		$L > 10"$	2/3
7/8"	$L \leq 3\text{-}1/2"$	1/3	1-1/2"	$L \leq 6"$	1/3
	$3\text{-}1/2" > L \leq 7"$	1/2		$6" > L \leq 12"$	1/2
	$L > 7"$	2/3		$L > 12"$	2/3

Tolerances: For 1/3 & 1/2 turn, ± 30 degrees; For 2/3 turns ± 45 degrees

CALIBRATED WRENCH INSTALLATION

1. At start of each day, complete pre-installation tension calibration for each bolt assembly to be installed.
2. A hardened (F436) washer is required under turned element.
3. Bring all bolts into snug tight condition following systematic procedure.
4. Match mark the nut or chuck.
5. Holding the bolt head or nut, tighten the nut or bolt until the wrench shuts off.
6. Verify that the wrench did achieved the rotations as shown in turn-of-nut method within tolerances shown in Table E-2.

TWIST-OFF TENSION CONTROL BOLT INSTALLATION

Installation procedure shall follow manufacturers recommendations and as follows;

1. At start of each day, complete pre-installation tension calibration for each bolt assembly to be installed.
2. Bring all bolts into snug tight condition following systematic procedure.
3. Using systematic approach, tighten each assembly using installation wrench until the bolt spline shears off.

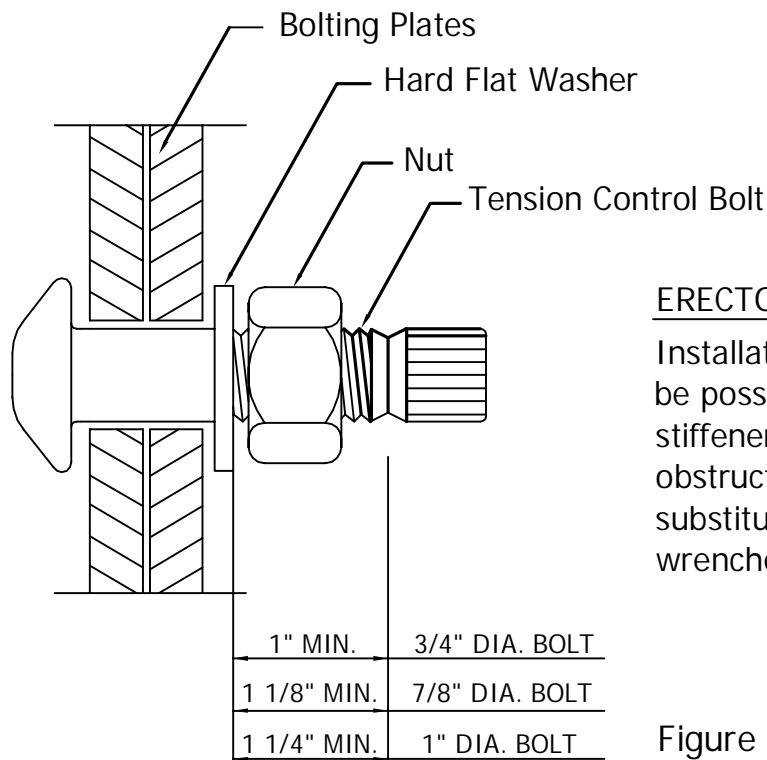

ERECTOR NOTE:

Installation of tension control bolts may not be possible in areas where extreme pitch, stiffener location, beam depth or other obstructions may occur. In these cases, substitution of nuts and bolts tightened with wrenches are required.

Figure E-10

Shear wrench (BY BLDR.) req'd for installation of tension control bolts.

DIRECT TENSION INDICATOR WASHER AND BOLT
INSTALLATION

Installation procedure for DTI washers shall follow manufacturers recommendations and as follows;

1. At start of each day, complete pre-installation tension calibration for each DTI washer and bolt assembly to be installed.
2. Bring all bolts into snug tight condition following systematic procedure. Do not fully compress the DTI at this step. See Table below for maximum number of feeler gage refusals at snug tight condition.

Bolt Dia. (In)	No. of Gaps	Max. Refusals at Snug
1/2"	4	1
3/4"	5	2
7/8"	5	2
1"	6	2
1-1/8"	6	2
1-1/4"	7	3
1-3/8"	7	3
1-1/2"	8	3

Feeler Gage Gap	
Uncoated DTI with DTI placed under bolt head wo/ washer	.015"
Uncoated DTI's w/ protrusions placed against washer.	.005"

3. Using systematic approach with DTI washers positioned as shown, tighten each assembly until DTI is compressed to proper inspection gap.

INSPECTION OF BOLTED JOINTS

GENERAL INSPECTION OF FEILD BOLTED CONNECTIONS

Installation shall be done as required by the local building official or project professional (AHJ). Special Inspectors must be pre-approved by the AHJ. As a minimum, bolting inspection tasks are as follows unless waved or modified by the AHJ. Field inspection costs are not the responsibility of BBNA.

INSPECTION TASKS

QC = Quality Control tasks are to be completed by the erectors QC Inspector (QCI).

QA = Quality Assurance tasks are to be completed by a 3rd party inspection agency when a QA firm is required by AHJ or owner. The Quality Assurance inspector (QAI) shall be qualified on the basis of documentation training and experience in structural bolting inspection.

O = Observe. "Observe" is defined as; "Observe on a random basis. Operations need not be delayed pending observations".

P = Perform these tasks for each structural bolted connection.

TABLE E-3

Inspection Tasks PRIOR to Bolting	QC	QA
Manufacturer's certifications available for fastener materials	O	P
Fasteners marked inaccordance with ASTM requirements	O	O
Proper fasteners selected for the joint detail (grade, type, bolt length)	O	O
Proper bolting procedure selected for the joint detail	O	O
Connection elements, including the appropriate faying surface condition and hole preparation, if specified, meet applicable requirements	O	O
Pre-installation verification testing (calibration) by installation personnel observed and documented for fastener assemblies and methods used	P	O
Proper storage provided for bolts, nut, washers and other fastener components	O	O

TABLE E-4

Inspection Tasks DURING to Bolting	QC	QA
Fastener assemblies, of suitable condition, placed in all holes and washers (if required) are positioned as required	O	O
Joint brought to the snug-tight condition prior to the pretensioning operation	O	O
Fastener component not turned by the wrench is prevented from rotating	O	O
Fasteners are pretensioned in accordance with Table E-1 progressing systematically from the most rigid point toward the free edges	O	O

TABLE E-5

Inspection Tasks AFTER to Bolting	QC	QA
Document acceptance or rejection of bolted connection	P	P

SNUG-TIGHT CONNECTION INSPECTION

Inspection tasks in Table E-3 and E-4 are NOT required for snug-tight connections. The QCI and QAI need not be present during installation. Inspection After Snugging of Bolts;

- Observe that firm contact has been achieved as described above in this guide. Note: Small gaps are permitted as described above (Gaps in Joints).
- Observe that nuts cannot be turned by hand on randomly selected joints.
- Complete documentation tasks per Table E-5.

TURN-OF-NUT METHOD INSPECTION

Complete all tasks indicated in Tables E-3, E-4, and E-5.

- Observe to verify the proper techniques of the turn-of-the-nut method.
- If match marking has been used, confirm after pre-tensioning that proper rotation has been provided per Table E-2. If match marking has been used, the QCI and QAI need not be present during installation.

- If no match marking is done, perform routine OCI (and OAI if required) observation of installations to ensure proper rotation is achieved. The wrench chuck should be marked and watched for proper rotation.
- Record or mark joints and/or bolt groups that have been inspected.

CALIBRATED WRENCH METHOD INSPECTION

Complete all tasks indicated in Tables E-3, E-4, and E-5.

TWIST-OFF TENSION CONTROL BOLT INSPECTION

Complete all tasks indicated in Tables E-3, E-4, and E-5.

- Observe that spline has been properly twisted off the end of the bolt.
- Record or mark joints and/or bolt groups that have been inspected.

DIRECT TENSION INDICATOR WASHER INSPECTION

Complete all tasks indicated in Tables E-3, E-4, and E-5.

- Observe that DTI washer has been compressed as required. One half or more the gaps must be compressed. All gaps need NOT be fully compressed.
- Record or mark joints and/or bolt groups that have been inspected.

FOUNDATIONS & ANCHOR RODS

All anchor rod embedment requirements and details shall be designed and furnished by others. Rod details shown are for illustration only.

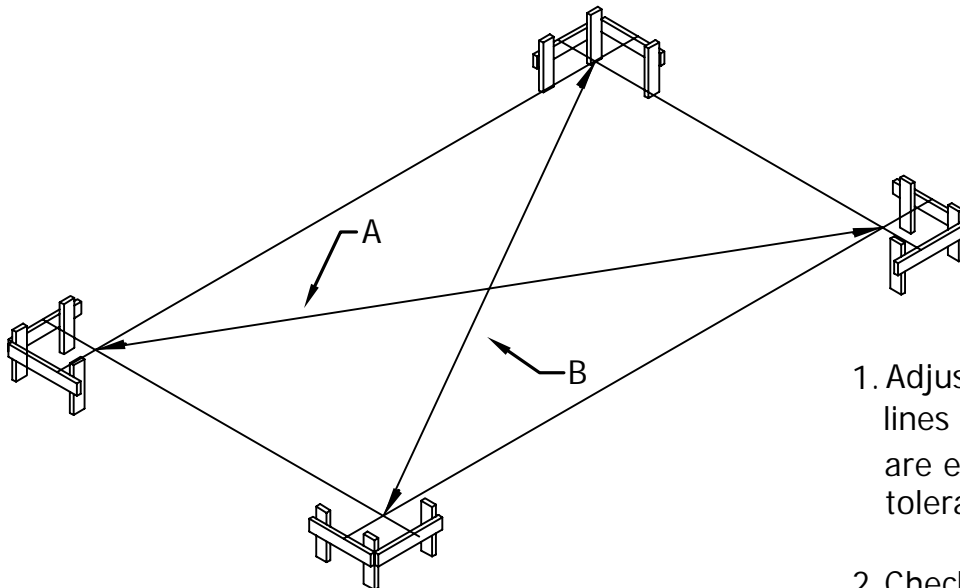

DIAGONAL METHOD

1. Adjust the foundation layout lines until dimensions A & B are equal in length. $\pm \frac{1}{4}$ " tolerance
2. Check again for correct building length and width per building drawings. $\pm \frac{1}{4}$ " tolerance

NOTE:

With either method, use a transit to set the top elevation of all batter boards at required elevation.

Bottom of base plate elevation tolerance may not exceed $\pm \frac{1}{8}$ " from specified elevation.

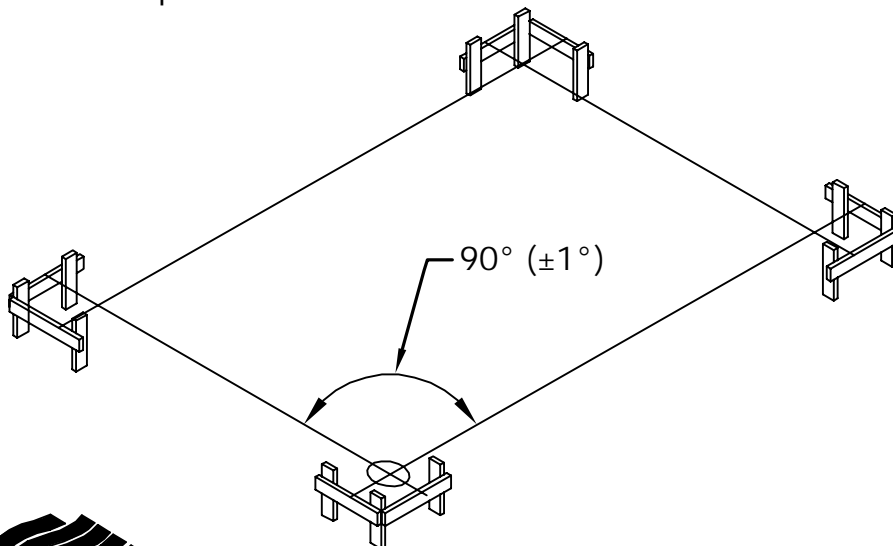

TRANSIT METHOD

1. Locate transit exactly over corner intersection point of string line.
2. Sight along one building line. Rotate transit through 90° to establish adjacent building line.
3. For accurate results, transit must be exactly level and properly calibrated.

Anchor Rods shall be placed as shown on FOR CONSTRUCTION anchor rod plan ONLY. DO NOT pour concrete from any other document for plans.

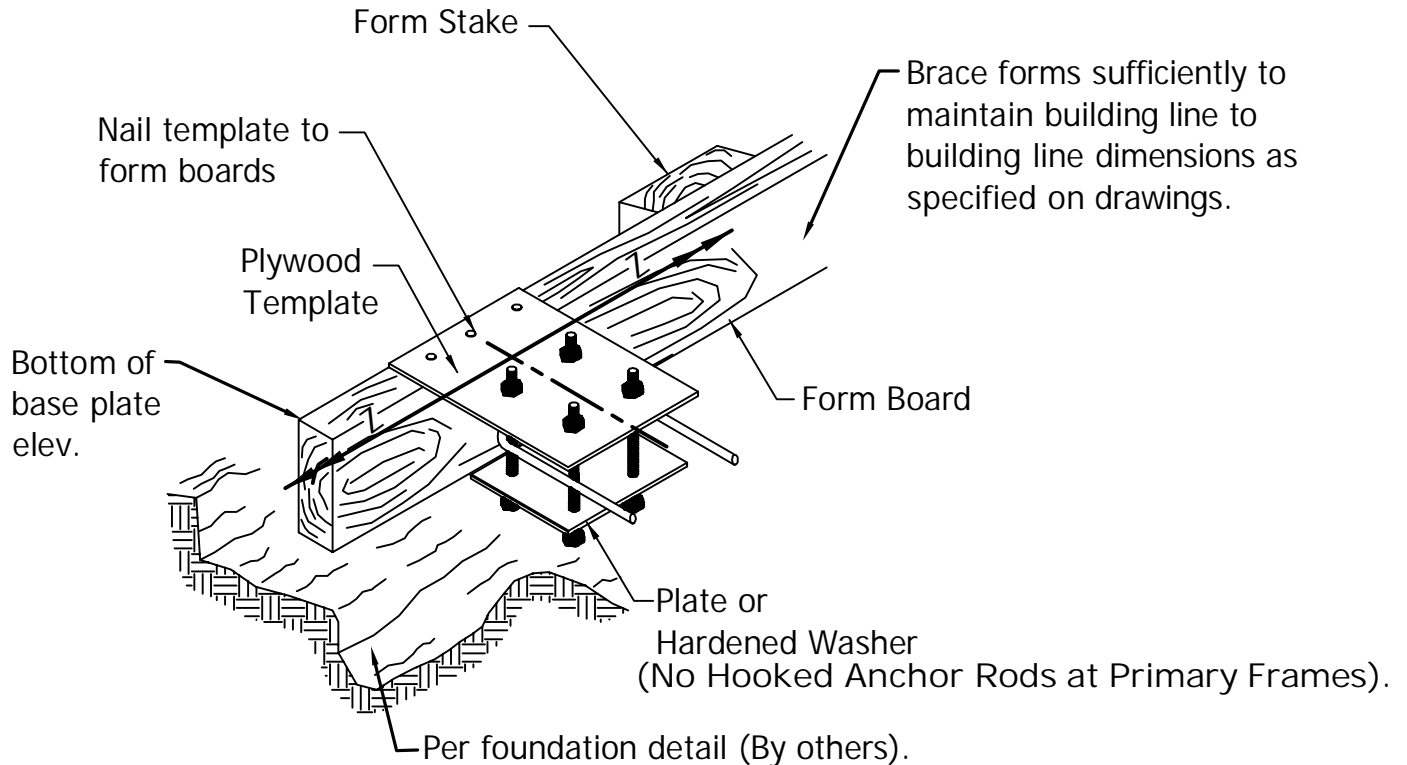

NOTE:
Protect rod threads during pouring of concrete.

NOTES:

- 1) Anchor rod diameter and setting dimensions are shown on the detailed anchor rod layout plan.
- 2) Mark form for template location before pouring. Set anchor rods and attach templates after screeding.
- 3) Z Dim. Tolerance Prior to pouring, verify as follow.
 - Z/Dim (Bay to Bay) not to exceed $\frac{1}{4}$ ".
 - Accumulated variation in Z Dim. $\leq \frac{1}{4}$ " per 100ft, Not to exceed 1".

IMPORTANT:

All reinforcing steel for foundation walls, footings, grout, tie rods, hair pins, wire mesh, or any other steel used specifically for concrete application shall be designed and furnished by others. All reinforcing steel shown in this manual is for illustrative purposes only.

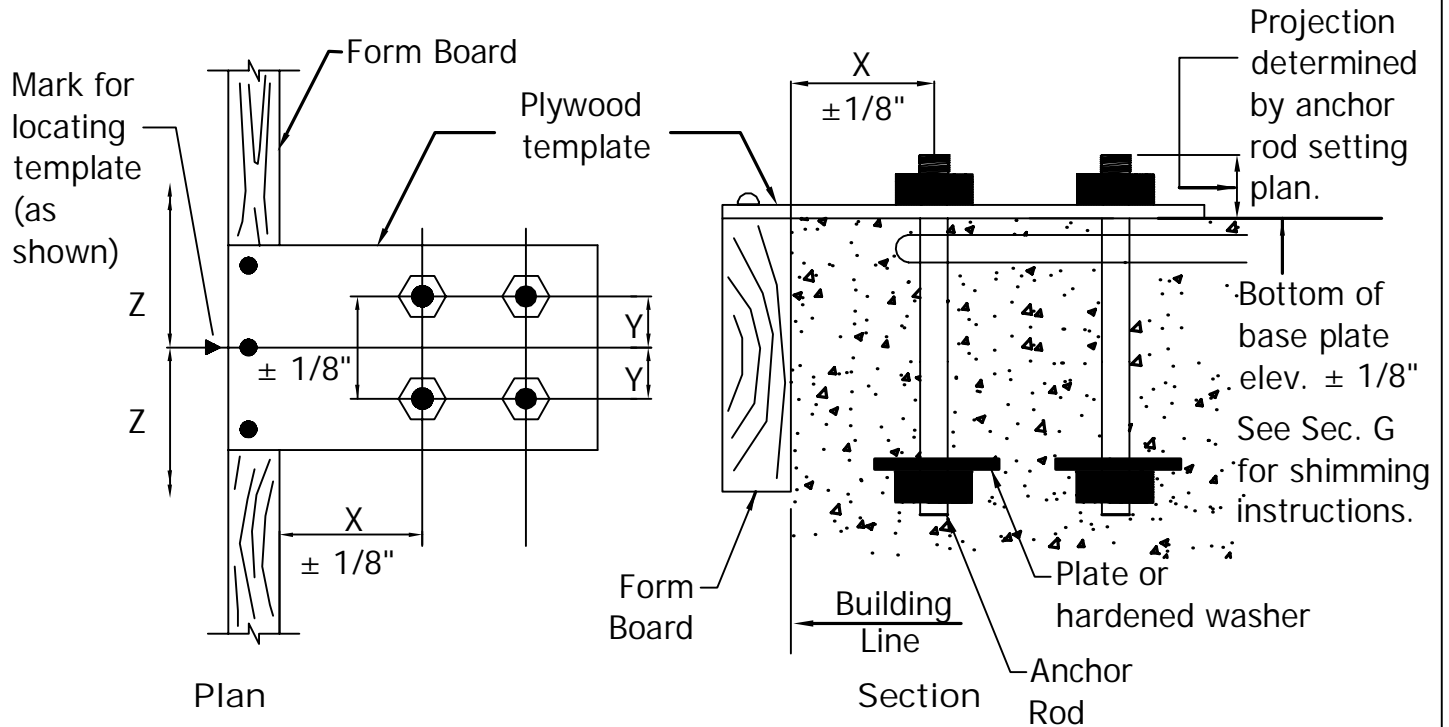

Minimum Rod Thread Engagement

Top of anchor rod must be at least flush with top of nut.
Additional Anchor Rod length may be required when grout is required

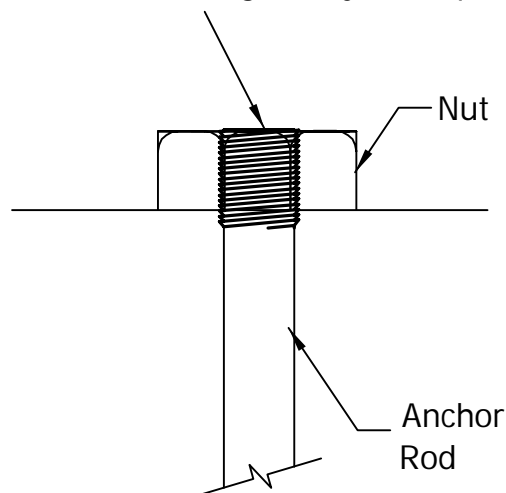

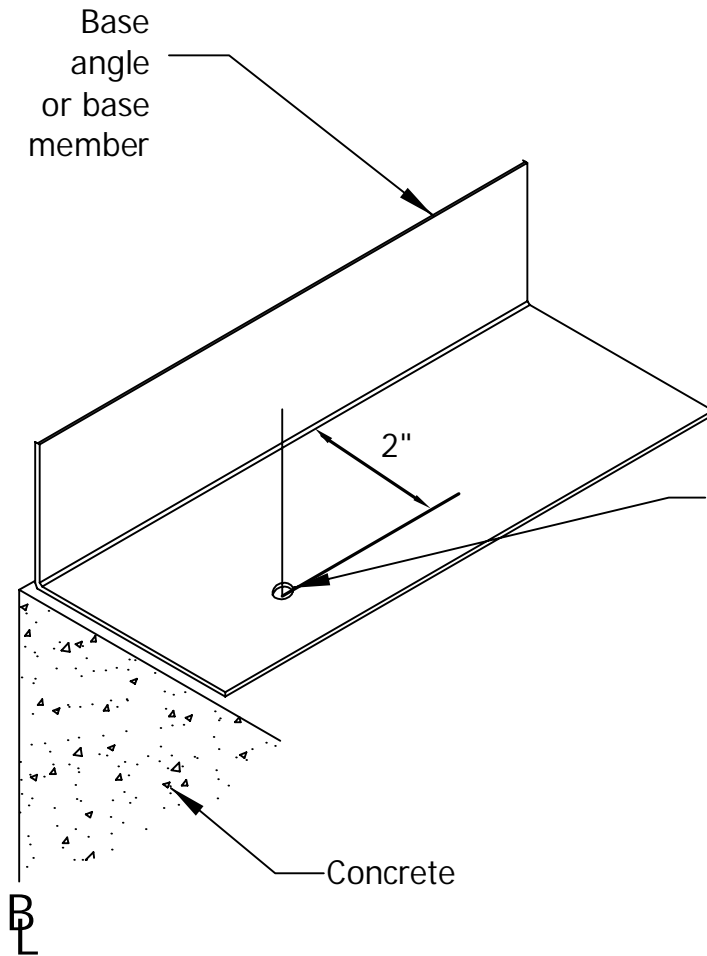

Attach to floor with $\frac{1}{4}$ " dia. power actuated concrete anchor (or other approved methods). Space anchors as shown on erection drawings and details.

NOTE:
Fastener should be located as far from outside edge of slab as is reasonable to prevent concrete spalling.

ERECTION PROCEDURE / PRIMARY FRAMING

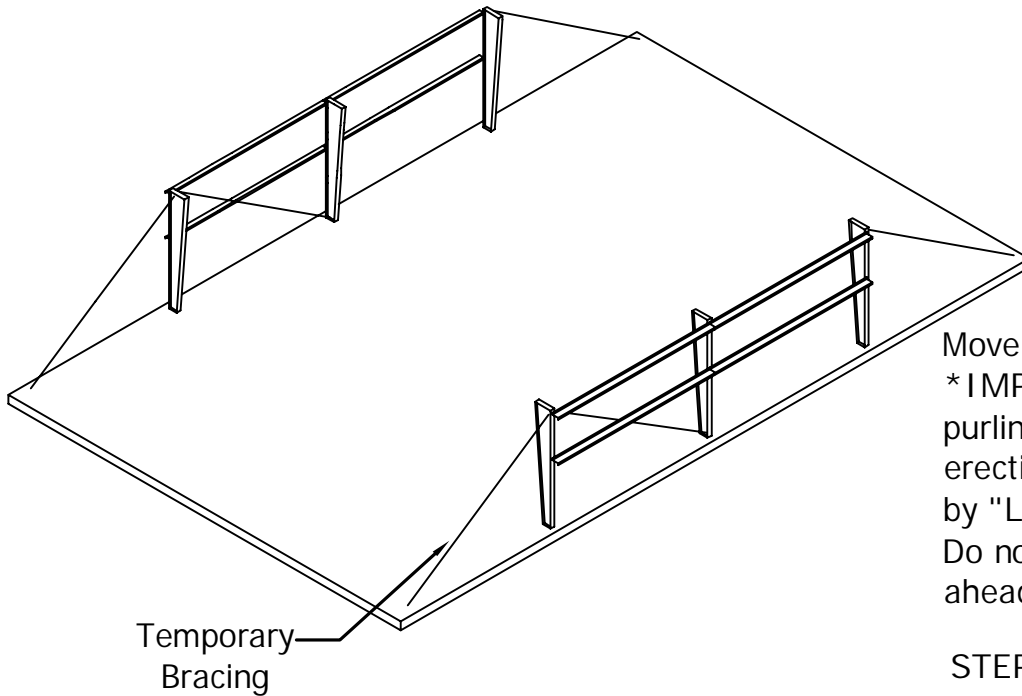

Move braces as steel is erected.
 IMPORTANT keep purlins/girts in tension as erection progresses, by "LEAP FROGGING" braces. Do not erect more than two bays ahead of the temporary braces.

STEP ONE

1. Check anchor rod plan and erection drawings for special conditions.
2. Stand column, install anchor rod nuts and temporary bracing. Install girts, flange braces, and all bolts.
3. The number of girts and temporary bracing required to secure columns shall be determined by erector.

NOTE:

1. Plan to erect a braced bay first. Usually this is the first interior bay from either end of the building.
2. Refer to the bolt tightening section (Section E) for acceptable methods of tightening bolts.
3. Bolt in place as many clips and flange braces as possible before raising frame to reduce in-the-air erection time.
4. It is the responsibility of the erector to provide temporary erection bracing until the structure is complete.
5. It is highly recommended that the erector consult with the overall project professional for advice on temporary bracing procedures.

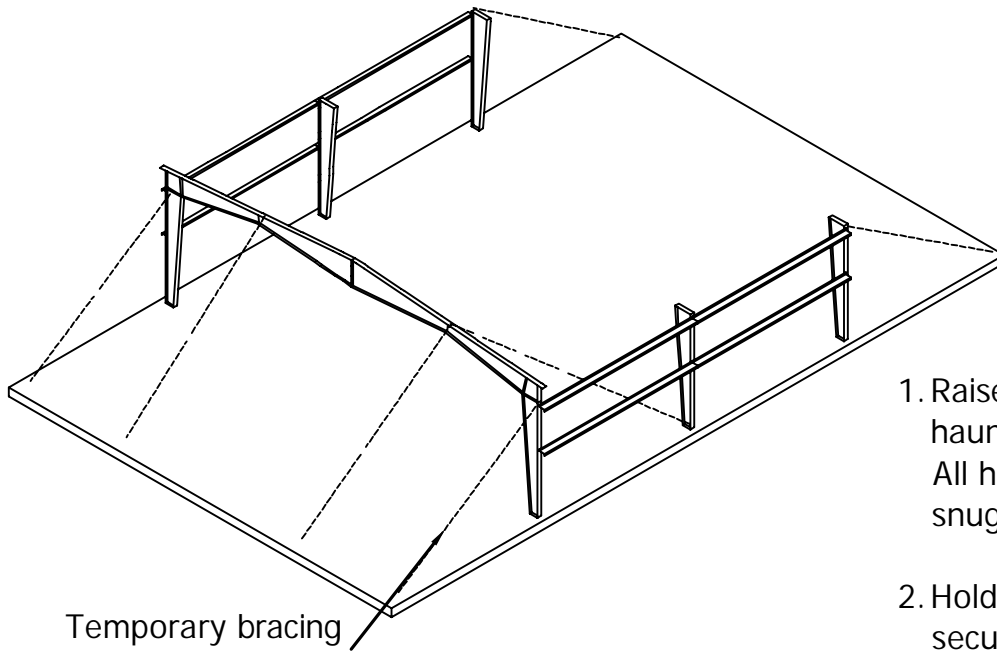

Temporary bracing
per building frame
requirements.

STEP TWO

1. Raise first rafter beam and haunch frame section into place. All high strength bolts are to be snug tightened before raising.
2. Hold in place until this section is secured to columns and temporary bracing is tied off to hold frame in place.
3. If interior columns are present, install temporary bracing at interior columns, in addition to braces shown.

ASSEMBLE ROOF BEAM SECTIONS

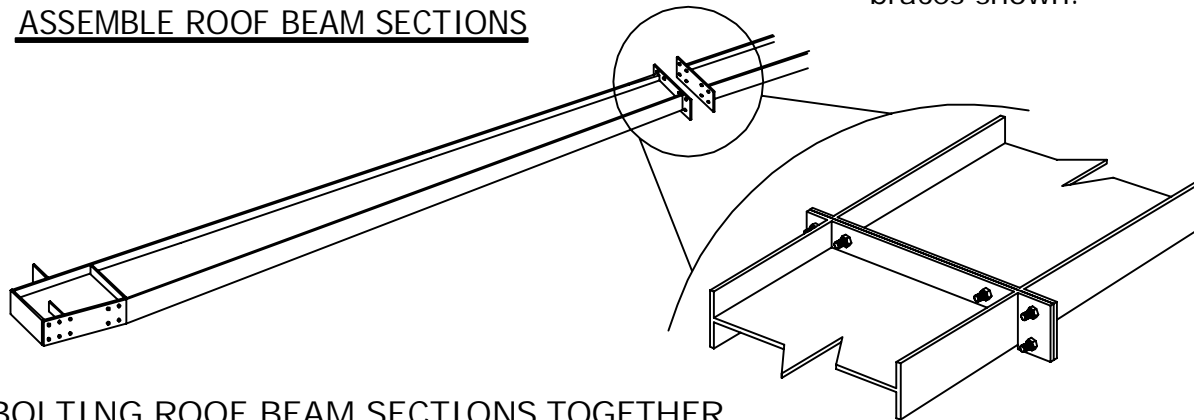

BOLTING ROOF BEAM SECTIONS TOGETHER

Rigid frame roof beams are shipped in two or more sections which must be bolted together at the jobsite. Layout and block up roof beams in the relative position of assembly. Butt sections together and align holes in the ridge plates, then bolt up. Draw bolts up evenly. When assembling frames on the ground, it is recommended that bolts be installed to the "snug tight" condition. After frames are lifted into position, tighten to "pretension" condition, if required.

See Section E for bolt installation and shimming requirements.

Primary Frame Assembly

Shown below are methods which may be used for rigging slings for lifting roof beam assemblies.

NOTE: Regardless of the method you use, make sure it is suitable and adequate for the job when considering the weight and size of the roof beam assemblies and hoisting equipment available. Roof beam sections are blocked up to facilitate assembly and to enable other parts to be attached.

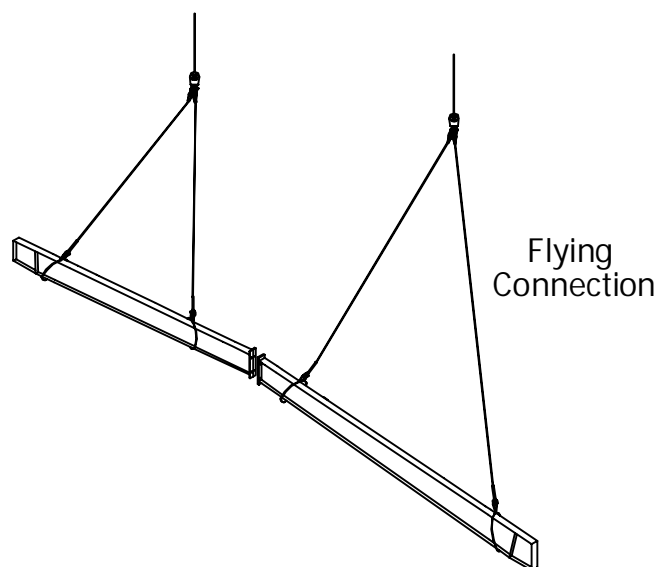
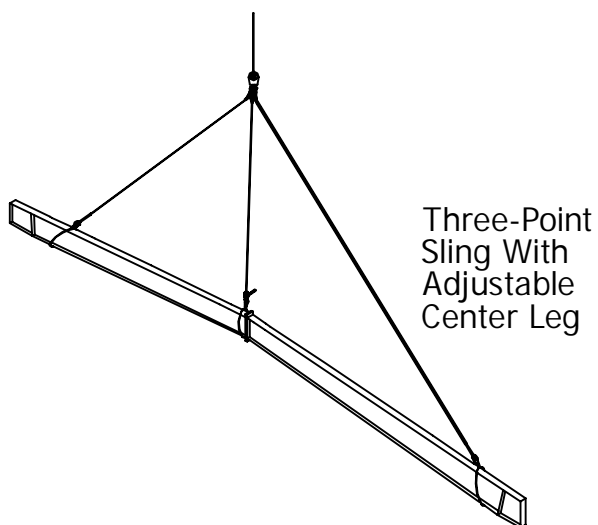
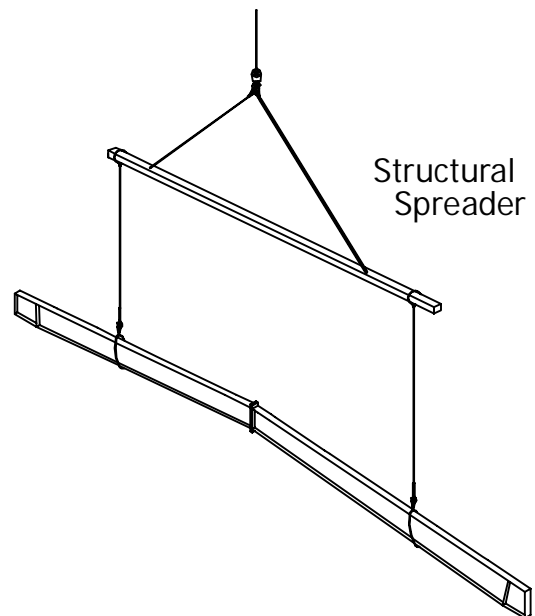
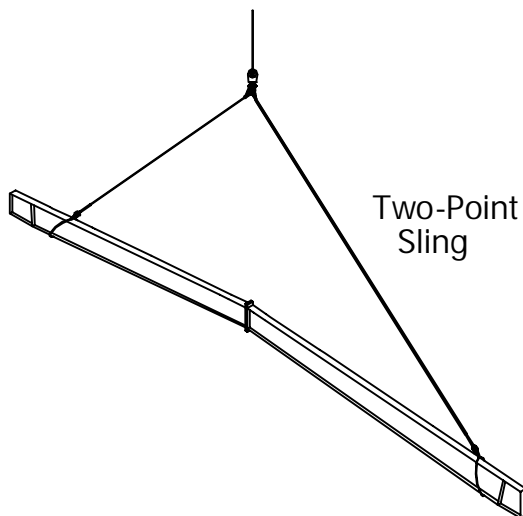

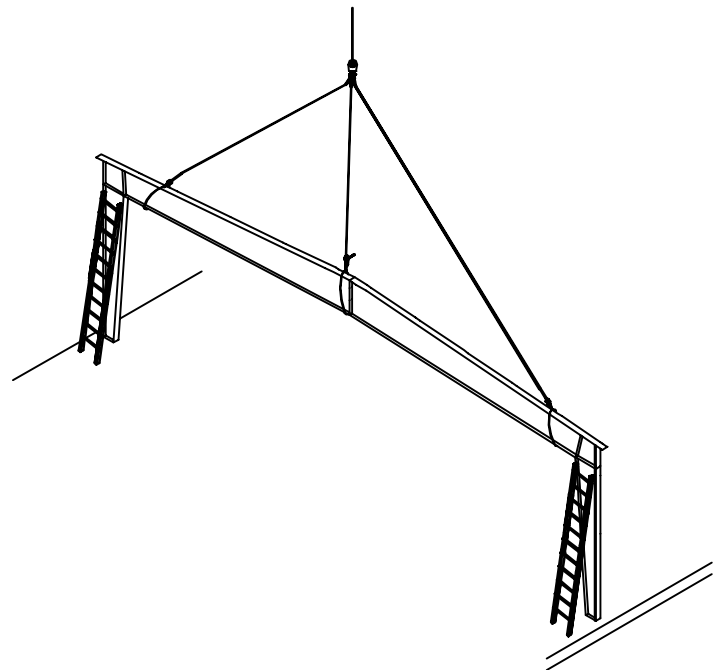
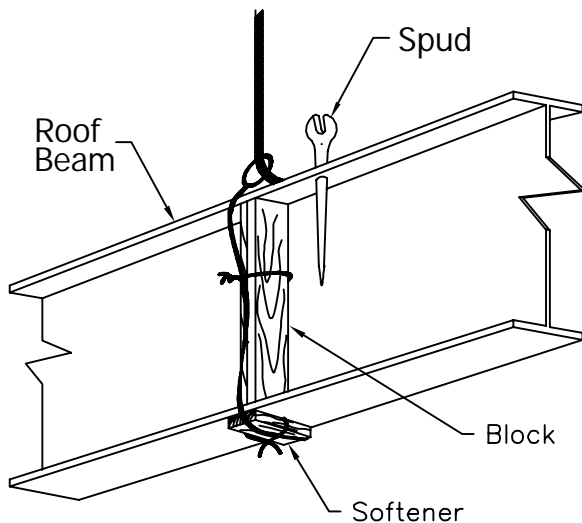

SLING WITH SOFTENER

Block between flanges to avoid damage to roof beam. Softeners should be used at the sling connections to avoid damaging the chokers.

After the sling is secured to the roof beam assembly, make a test lift to determine if the sling is properly positioned. Insert a spud through the hole in the roof beam flange at the sling connections to prevent sling from slipping. The sling is correctly positioned when test lift indicates minimum frame distortion. Note the location of the sling connections for positioning on the remaining roof beam assemblies. While the roof beam assembly is still accessible from the ground, connect tag lines and guy lines for guiding the roof beam into place and tying off the rigid frame after erection.

Avoid inducing impact to roof beams when lifting or setting on the columns.

NOTE

Beam clamps can be effectively used to facilitate the handling of roof beams. Beam clamps attached to the top flange of the beams permit the beam to hang naturally in a vertical position. A choker wrapped around the beam lifts from the bottom and the beam is easily unbalanced.

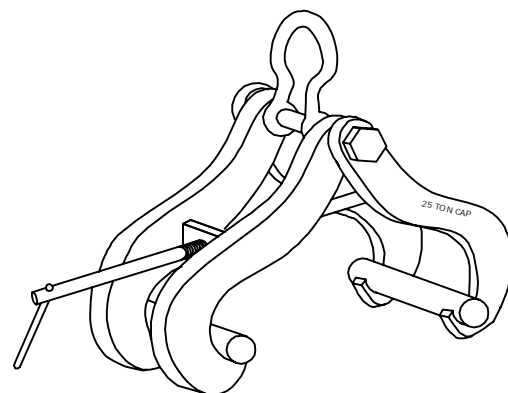

Beam Clamp

SETTING ROOF BEAM ON COLUMN (Face bolted connections similar)

Raise the roof beam assembly slowly and guide into position so roof beam flanges are aligned with column flanges and bolt in place.

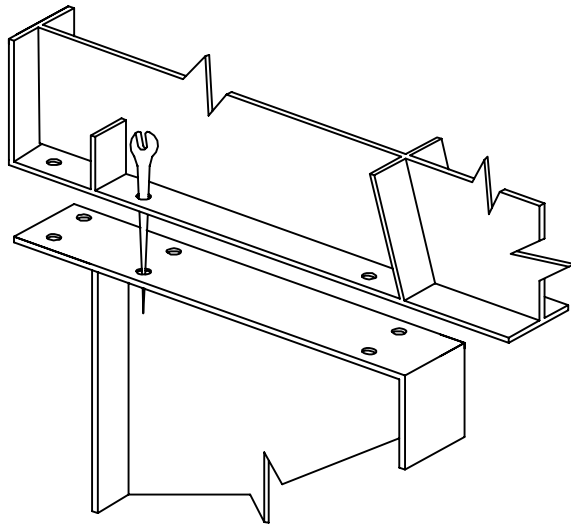

USE OF SPUD WRENCH FOR ALIGNING HOLES

A spud wrench will be useful for aligning the holes. Secure the guy lines to stabilize the frame before releasing the crane.

CAUTION

Be very careful when tilting the assembled roof beams into a vertical position to avoid twisting which can damage the flanges.

CAUTION:

Beams will have a tendency to roll over until secondary and flange braces are installed. Do not release lifting rigging until beams are stabilized.

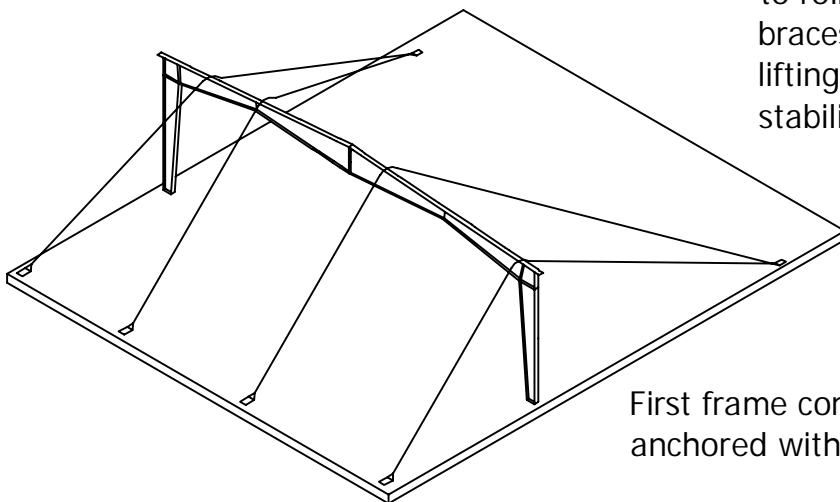

First frame completed and anchored with guy lines.

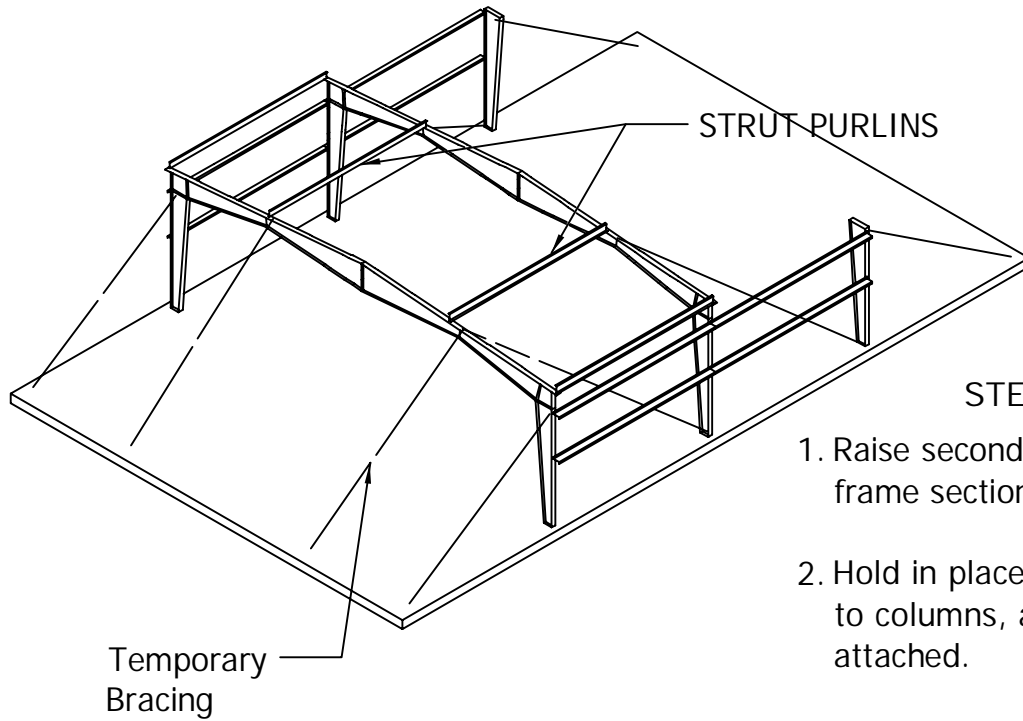

STEP THREE

1. Raise second haunch and roof beam frame section.
2. Hold in place until this section is bolted to columns, and lead purlins have been attached.
3. Add brace near strut purlin, keeping strut purlin in tension until purlin can be stabilized with intermediate channel braces or sheeting.
4. Continue to "Leap Frog" temp. braces as additional frames and purlin struts are installed.

NOTE:

It is the responsibility of the erector to provide adequate temporary bracing.

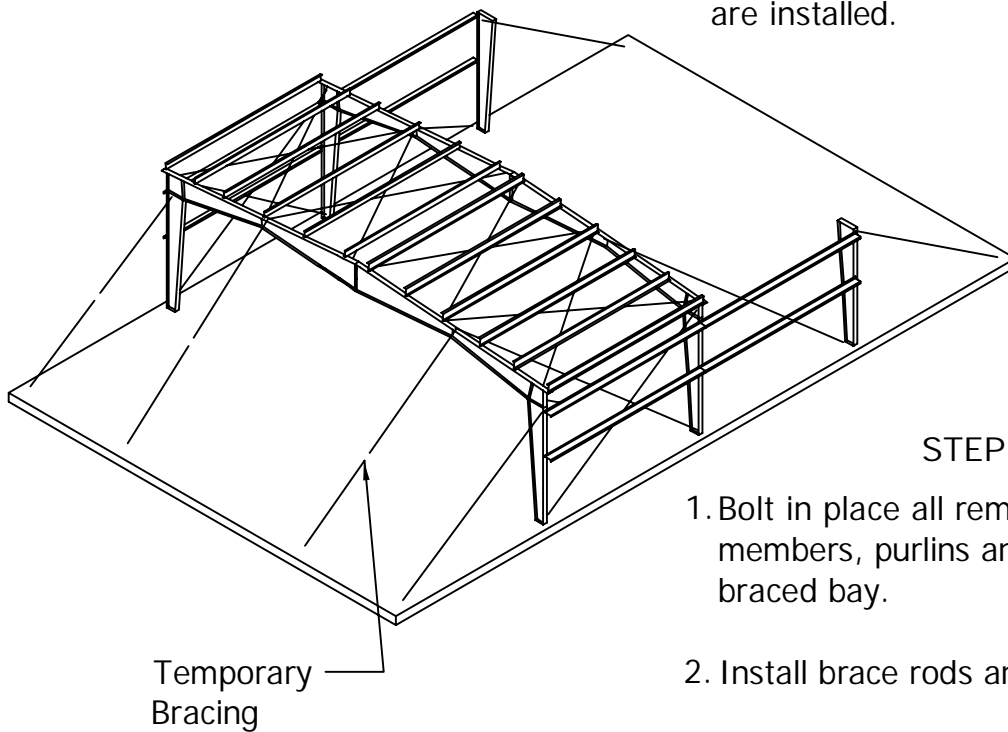

STEP FOUR

1. Bolt in place all remaining eave members, purlins and girts of the braced bay.
2. Install brace rods and flange braces.
3. Square and plumb braced bay before erecting adjacent bays.

SECTION G

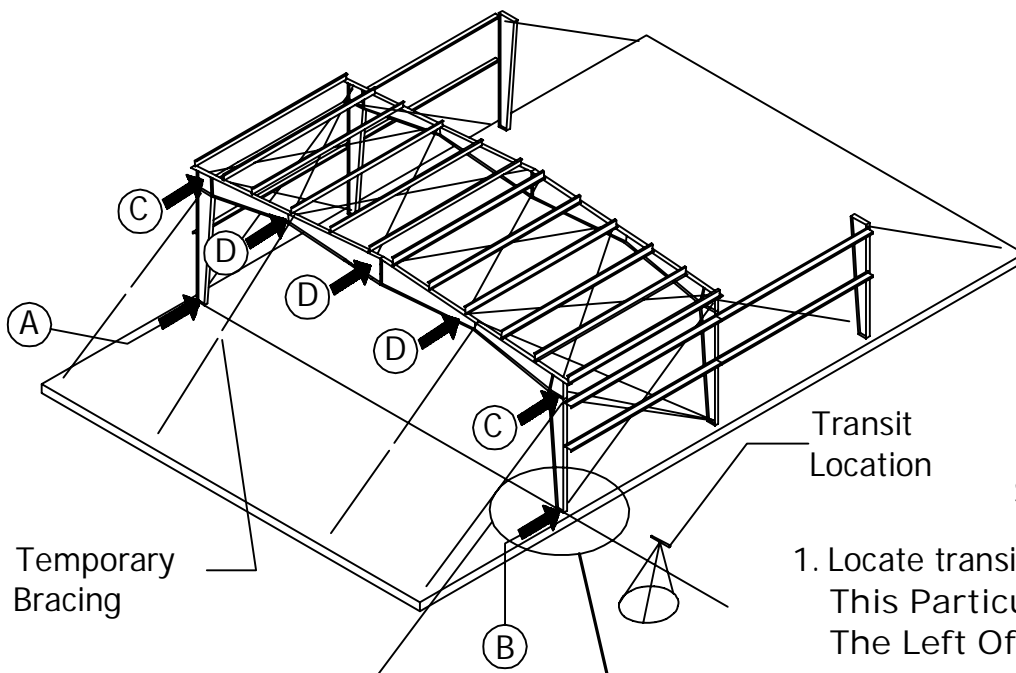

STEP FIVE

1. Locate transit as shown above (In This Particular Case Slightly To The Left Of The First Rigid Frame).
2. Make sure transit is perfectly level.
3. Rotate transit until you get the same exact tape reading at points A & B (Base Of Column.) Measure from web of column.
4. Lock horizontal rotation of transit.
5. Adjust rod bracing and temporary bracing until the tape reading at points A & B is obtained at all points indicated on above sketch. Take all readings from web of member.

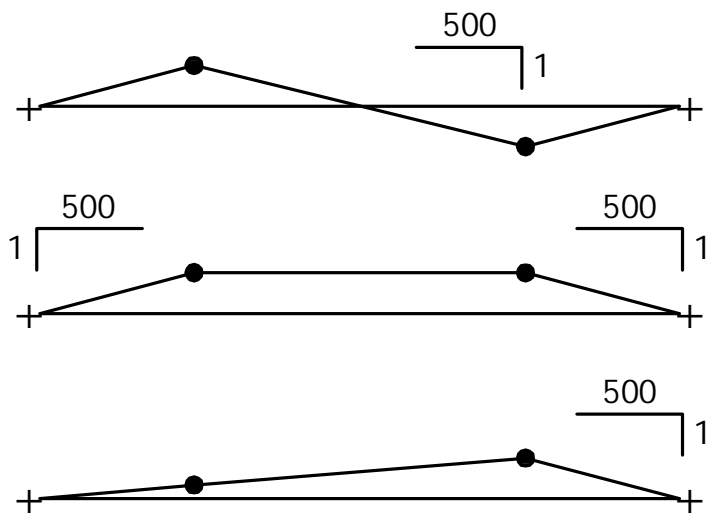
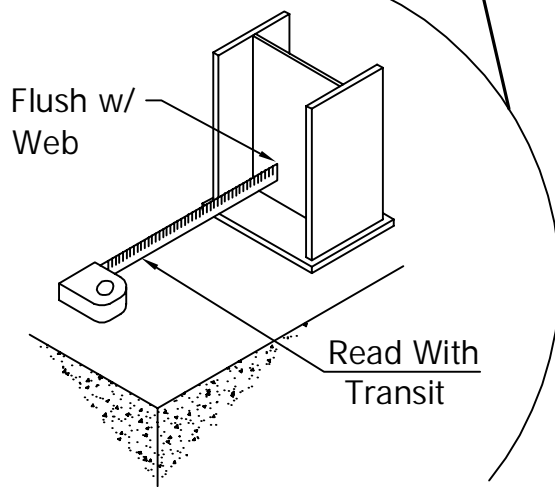

● Field Splices + Support Points

6. Columns shall be plumb at points C to within; height (IN)/500.

EX. $\frac{25\text{ft} \times 12}{500} = \pm \frac{5}{8}''$

7. Beams shall be straight from column to column (field splices Points D) to; span (IN)/500.



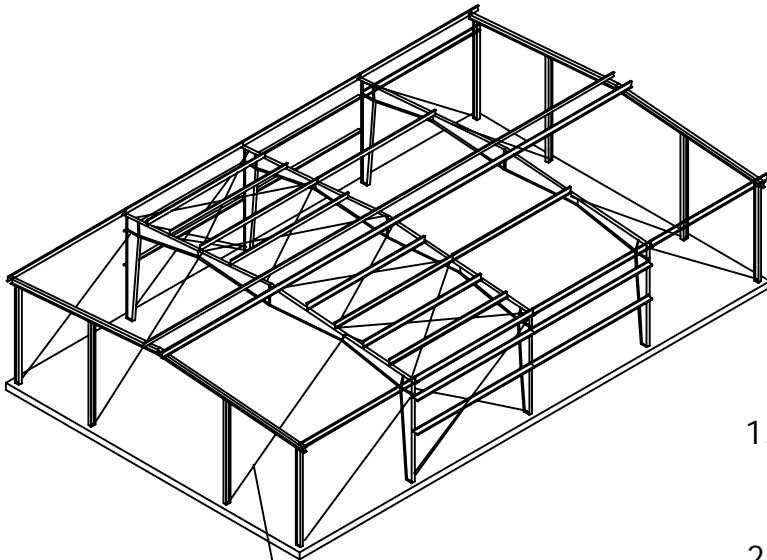

Temporary
Bracing

STEP SIX

1. Proceed with the erection of the remaining frames.
2. Plumb frames in longitudinal direction using similar procedure described in STEP 5. (Tolerance; $\leq \text{Height}/500$)

NOTE:

Remove temporary bracing only after all paneling has been installed.

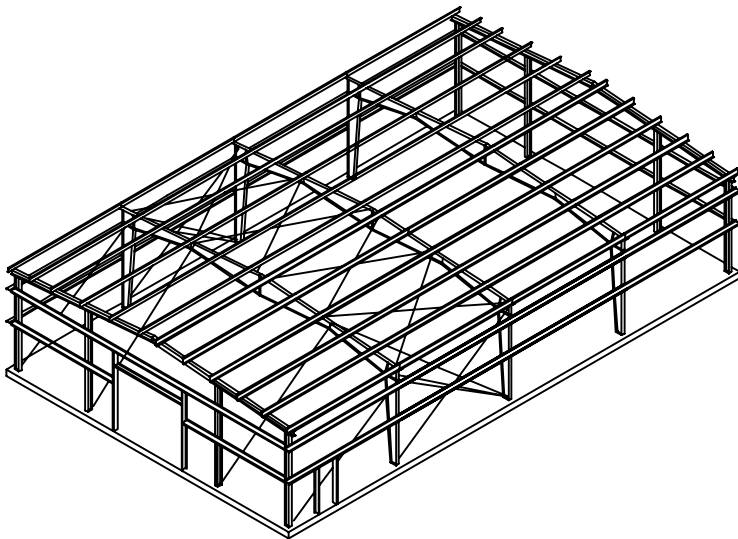

STEP SEVEN

1. Complete erection of all primary & secondary components.
2. Note that after completion of all secondary framing in one end bay, attachment of roof panels may commence and be worked in conjunction with the completion of primary & secondary framing.

COLUMN BASE SHIMMING

Column bases may be shimmed to adjust for concrete, erection, and fabrication tolerances to accommodate fitup of other members and plumbing / leveling.

Leveling of pinned base columns can be accomplished by placement of steel shims under the column base plates shown in Figure G-1.

Erector to supply rectangular shim plates. Shim packs may be used (I.E.- multiple shim plates may be stacked to desired thickness).

Shimming between multiple rows of anchor rods is not required as shown in Figure G-1. Place shim packs from edge of base plate to anchor rod as shown. Shim plates shall be same width as base plate.

Threads of nuts must be fully engaged on anchor rod. End of rod must be at least flush with top of nut. See Figure G-2.

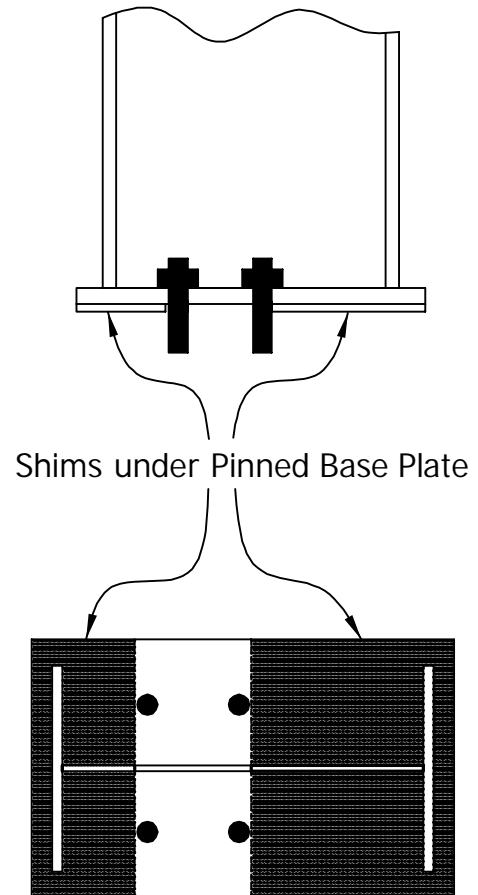

Figure G-1

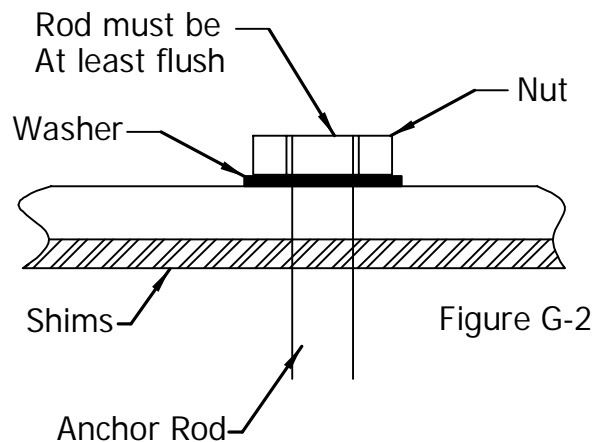
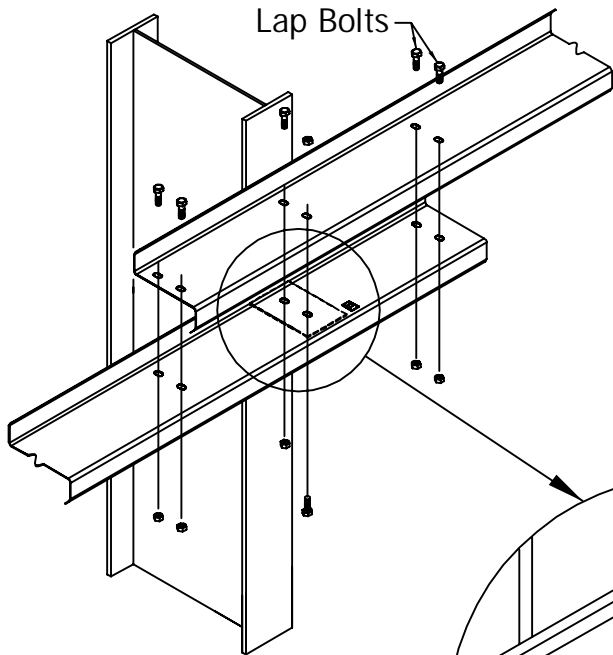
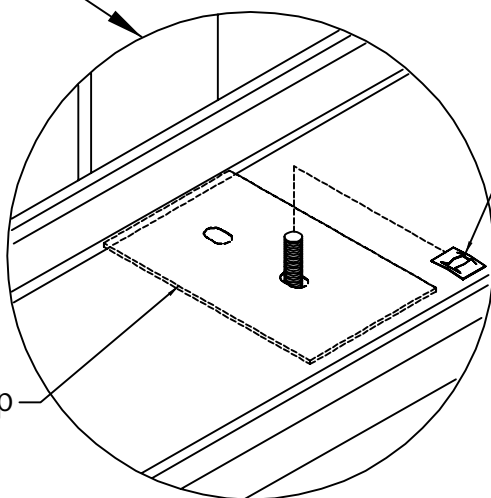

Figure G-2

Secondary Installation



Detail A



- Recommended procedure for safe installation of girts. Erector option to use other OSHA compliant methods.
 - Attach 1st member to clip w/bolt and retainer as shown in Detail A.
 - Install 2nd member over 1st member and retained bolt.
 - Install remaining bolts and nuts to complete the lapped joint.
- Bolt Retainer (97635)
Commercially available, or may be purchased thru BBNA.

ORIENTATION IS CRITICAL:
Install bolt retainer on bolt with prongs out..

Standard girt connection shown. Flipped connections similar, but opposite direction.

Girt Clip

WALL GIRT BLOCKING

Temporary blocking of girts is required to ensure girts are straight and level prior to installation of panels.

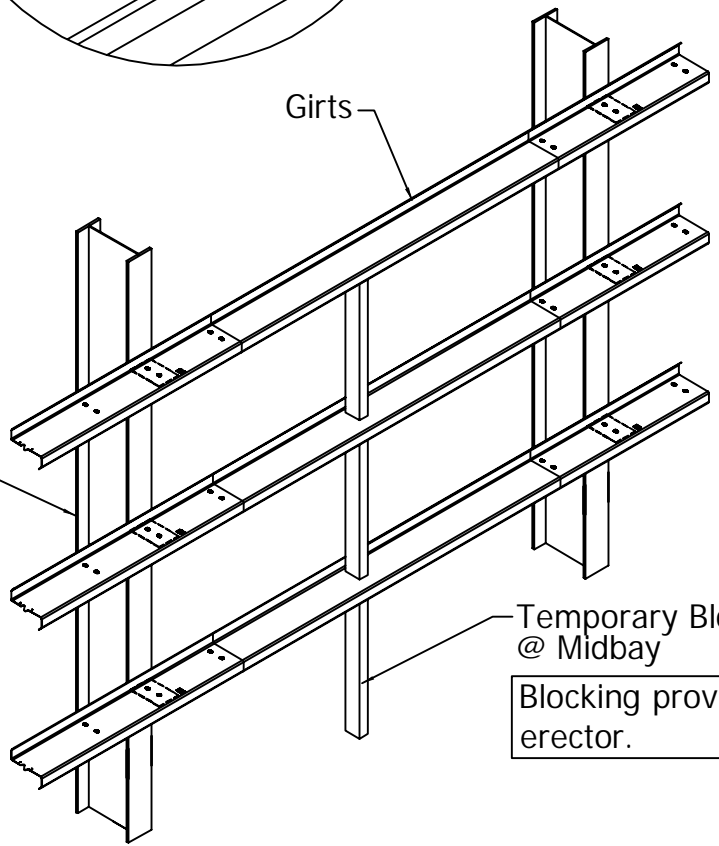

Girts and Purlins shall be installed to L/500 straightness tolerance.

EX. $\frac{25\text{ft} \times 12}{500} = \pm \frac{5}{8}"$

Temporary Blocking @ Midbay
Blocking provided by erector.



Standard & Flipped Secondary Orientations

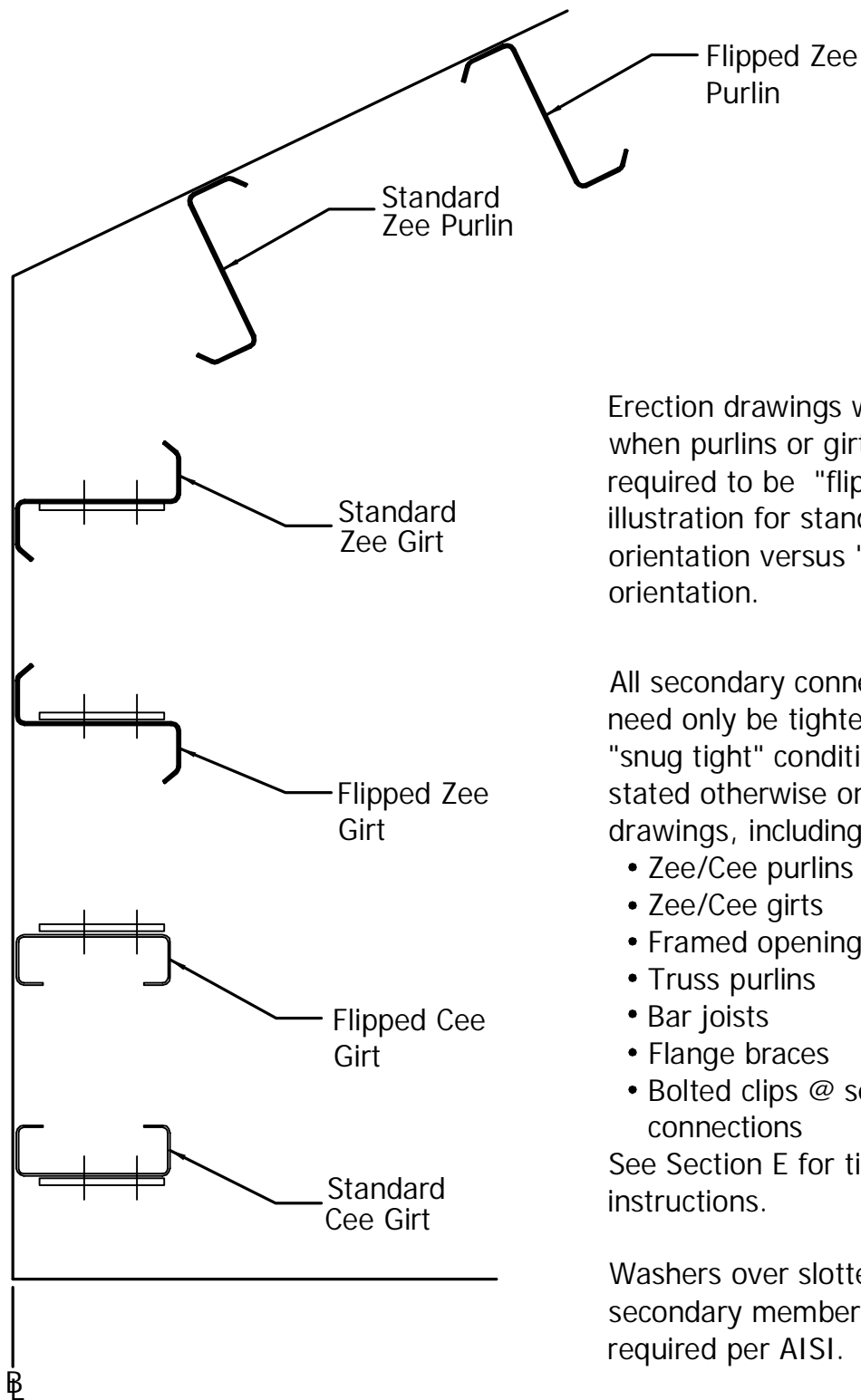

Erection drawings will indicate when purlins or girts are required to be "flipped". See illustration for standard orientation versus "flipped" orientation.

All secondary connections need only be tightened to "snug tight" condition unless stated otherwise on erection drawings, including:

- Zee/Cee purlins
- Zee/Cee girts
- Framed opening members
- Truss purlins
- Bar joists
- Flange braces
- Bolted clips @ secondary connections

See Section E for tightening instructions.

Washers over slotted holes in secondary members are not required per AISI.

GIRT/PURLIN ORIENTATION

SECONDARY ORIENTATION
H-2

ROOF PURLIN BLOCKING

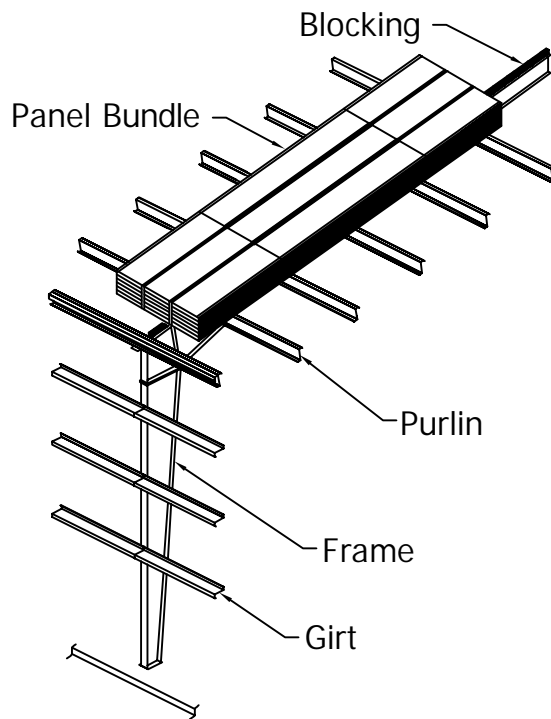

Roof panel bundles are often located on the roof structurals prior to installation.

This procedure can cause damage if the bundles are located over unsupported areas. If the bundles are to be located on the roof structurals, adhere to the following blocking procedure.

1. All structurals, flange bracing, permanent and temporary bracing, etc. must be in place and plumb. Tighten bolts before blocking is installed and panel bundles are placed on the roof.
2. Panel bundles should only be located over centerlines of frames, not over jack beams or jack trusses.

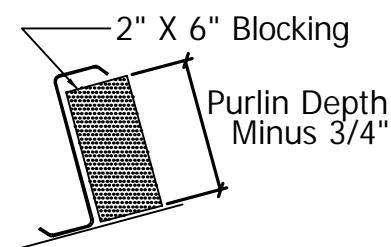
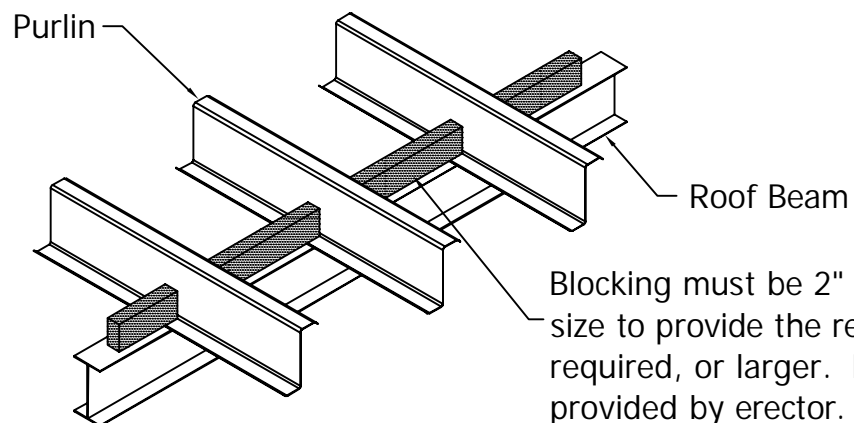

ALTERNATE
BLOCKING METHOD
(SEE NOTE 5)

3. Blocking should be installed between all purlins at frames where bundles are to be located. Length of blocking should be equal to purlin spacing.
4. Remove blocking after panels are installed.
5. When the alternate blocking method is used, the same procedures must be followed.

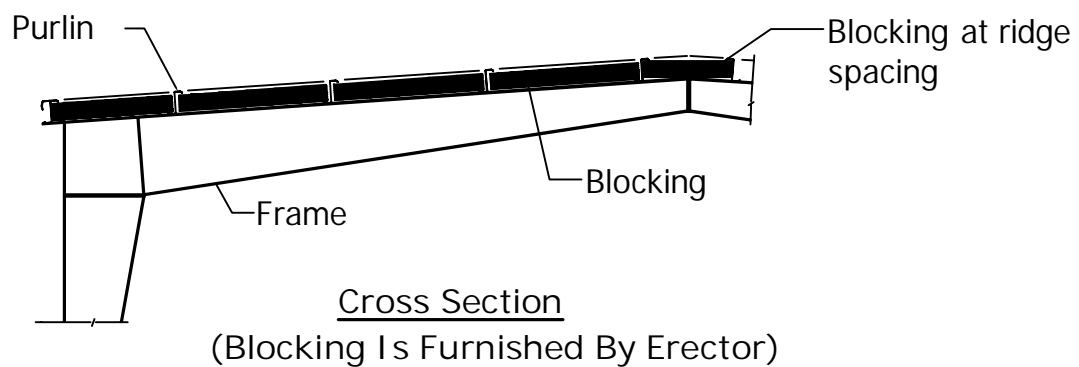

- Install all purlin channel braces or sag bracing BEFORE installing roof panels. See erection drawings for locations and details.

SECONDARY TRUSS PURLIN INSTALLATION

BlueScope Building's widebay truss purlins are factory bolted assemblies of cold-form light gauge components and are proprietary to BlueScope Buildings NA. As typical of any long span member, maintaining stability during erection is critical to safety and efficiency.

While TP's are NOT bar joists, most OSHA erection safety requirements and erection sequences required by OSHA also apply to TP's.



UNLOADING & SORTING

TP's are delivered in bundles in sequence order for each bay. Bundles should be located as near as possible to where shown on bundle layout drawings to minimize handling.



PANELIZED ERECTION (Super Set)

When sufficient equipment is available, panelized erection techniques are most efficient. Assemble an entire bay module on the ground and lift entire assembly at once.

Install ALL components including;

Rafters sections, all TP's, flange braces, top and bottom chord bridging, cross bridging, roof rod braces (if required in the bay), and tighten all bolts to snug tight condition.



Once assembled, the entire bay module is lifted into place. When using one crane to make the lift, be sure to use appropriate spreader bars to lift both rafter sections with approximately vertical picks.

STICK ERECTION

When installing TP's individually, both TP seats MUST BE bolted to the frame PRIOR to releasing hoist cable. If seats are welded, then welding must be completed before releasing hoist cables.

When erecting individual pieces, preassemble cross braced TP'S on the ground as shown. These are the terminus points for all other TP's in each bay. Be sure tag ends are on same end and installed per drawings.



Install terminus TP's first then fill in other TP's tying them together with horizontal bridging as installation progresses.

DO'S AND DON'TS

- Out-of Straightness erection tolerance - $L/500$
- Follow all requirements found in the OSHA Regulations.
- No load is permitted on any truss purlin other than the weight of one person until all bridging is installed.
- AFTER all bridging is installed and tied off to terminus brace temporary construction loads may be loaded onto TP's over primary frames extending evenly either side of primary frame. Total uniform weight (PSF) shall not exceed design uniform load shown on drawings.
- DO NOT cut or modify TP's in any way.
- DO NOT weld to TP's unless approved by engineering.
- DO NOT loosen or remove factory installed bolts. Factory installed bolts are installed with specially designed calibrated tightening tools specifically designed for the specialized proprietary hardware used in the assembly.
- For hanging loads from TP's, see erection drawing B-081769 for details.

ROD BRACING

SECTION I

Rod braces shall be tightened snugly such that the rod does not sag more than the Rod Length(Inches)/500.

EX. $\frac{35\text{ft rod} \times 12}{500} = \pm \frac{13''}{16}$

Long rods may require intermediate support from roof secondary members to reduce sag.

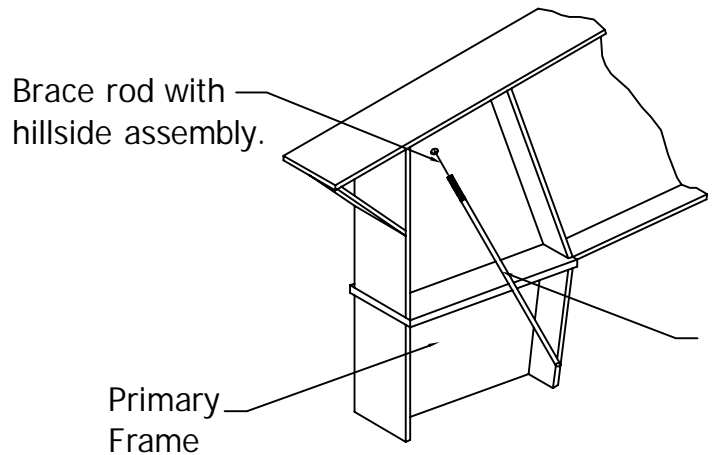

WALL BRACE DETAIL

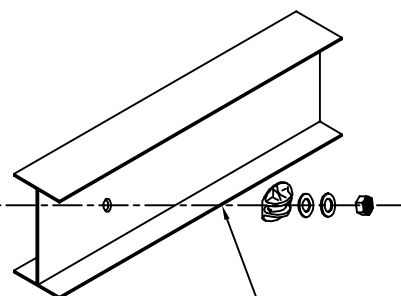

ROOF BRACE DETAIL

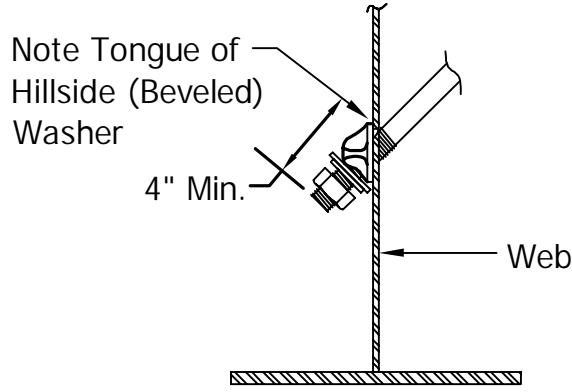

SECTION A-A

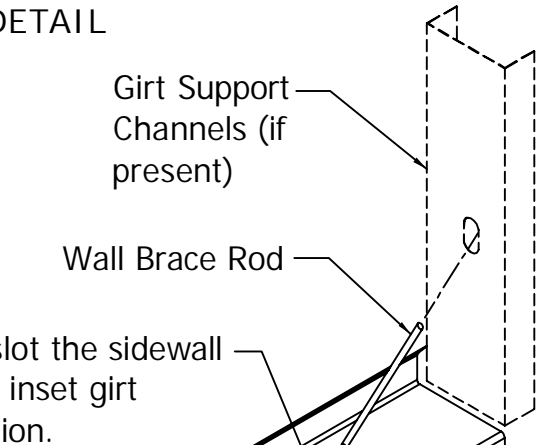

WALL BRACE DETAIL THRU INSET GIRT

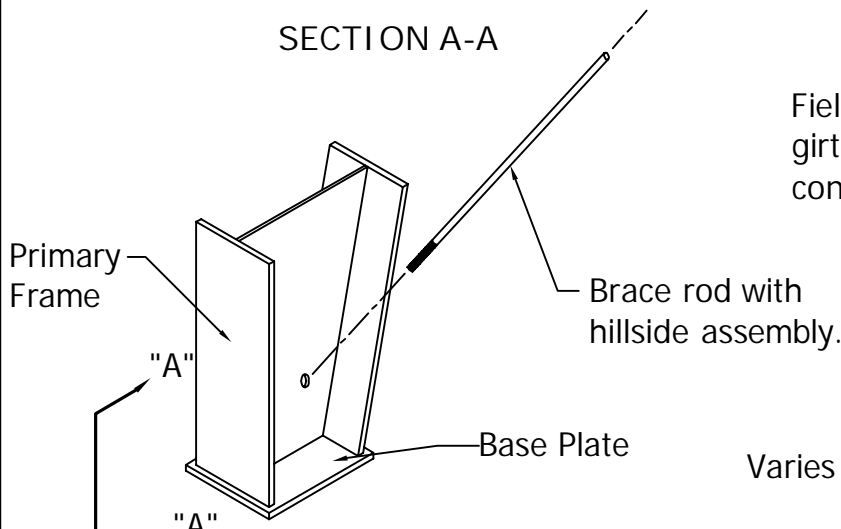

WALL BRACE DETAIL

Maximum 2" X 4" slot. Do not cut into girt flange.



Rod bracing "assembly" mark numbers are indicated on erection drawings. These mark numbers define all the parts needed to make up the "assembly". "Assemblies" that require more than one rod will be shipped bundled together with the "assembly" part mark attached. Assembly codes and required parts are shown below.

Typical "Assembly" Generated Mark Number (Example)

ROD BRACING
 0 3 R S 2 5 1 0 ——— Means 3/8" diam rod: RS assembly code: 25'-10" long

I	E	*	*	F	F	I	I	F = FEET	I = INCHES	E = EIGHTHS
DIA				LENGTH						

"RS" ROD BRACE ASSEMBLY
 ("RT" ASSEMBLY SIMILAR)

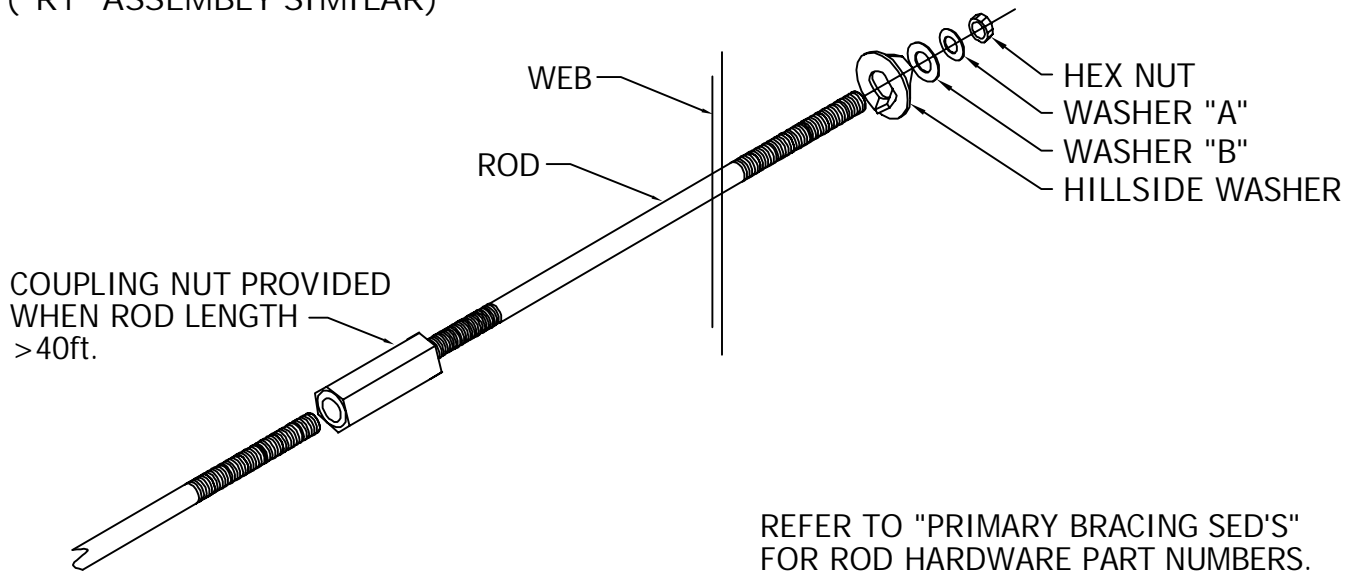

REFER TO "PRIMARY BRACING SED'S" FOR ROD HARDWARE PART NUMBERS.

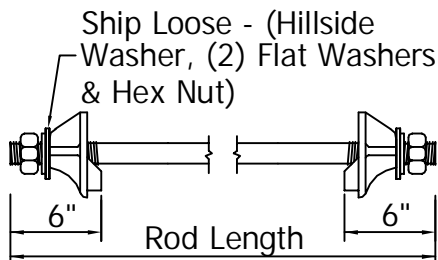

(As Shown On Erection Drawings)
RS RODS THREAD BOTH ENDS WITHOUT TURNBUCKLE

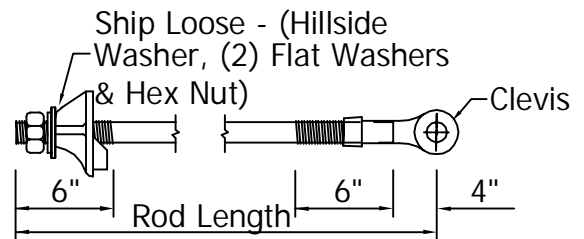

(As Shown On Erection Drawings)
RT RODS CLEVIS ONE END

"RU" ROD BRACE ASSEMBLY

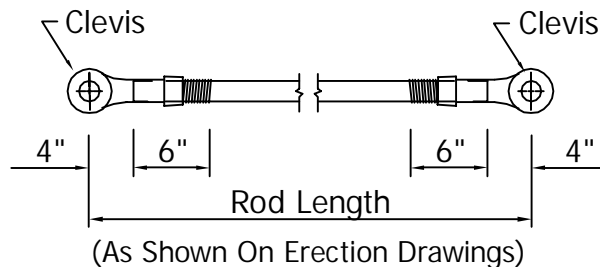
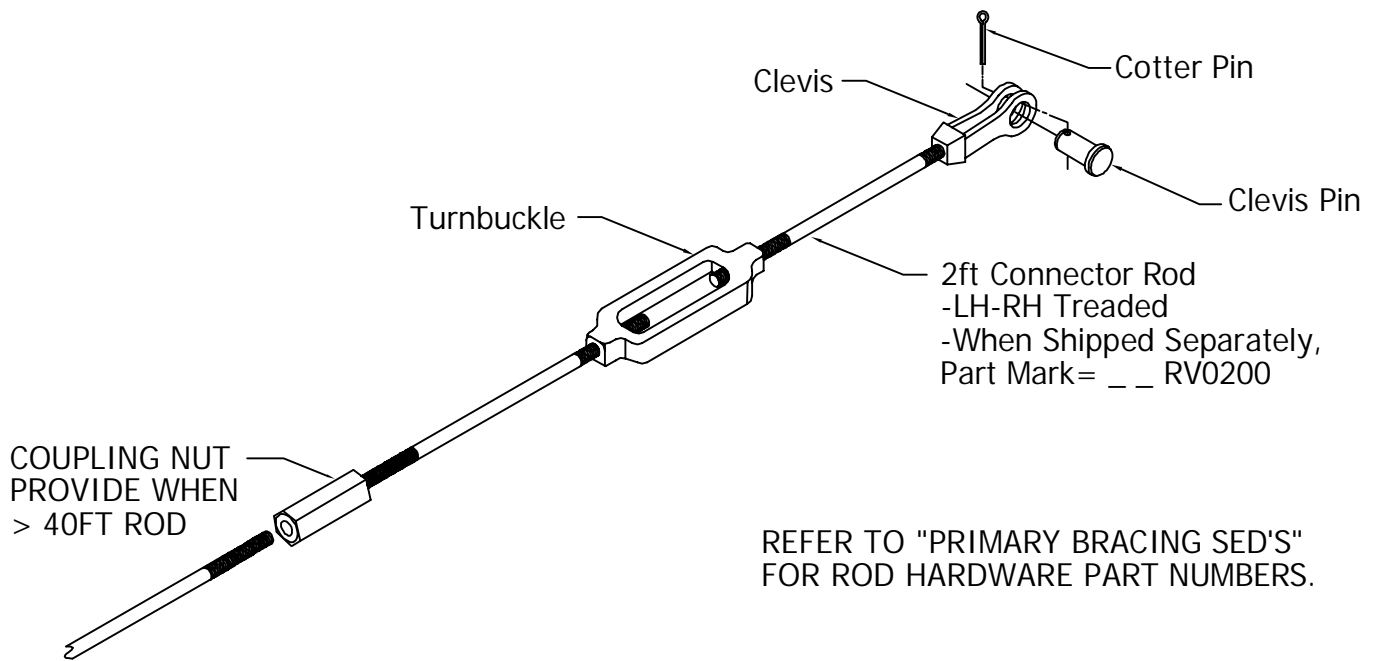

RU RODS CLEVIS BOTH ENDS

THREAD PROTECTION REFERENCE KEY FOR ROD BRACING

SLEEVE COLOR	ROD DIAMETER
BLUE	3/8"
BLACK	1/2"
RED	5/8"
YELLOW	3/4"
ORANGE	7/8"
GREEN	1"
WHITE	1 1/8"

ROD BRACE THREAD PROTECTION COLOR CODE KEY

CRANE RUNWAY ALIGNMENT

CRANE SYSTEMS MUST BE INSTALLED IN STRICT ACCORDANCE WITH CRANE MANUFACTURERS INSTRUCTIONS. ALL STEEL SUPPORT FRAMING MUST BE PLUMBED AND ALIGNED CAREFULLY FOR PROPER OPERATIONS.

IF CRANE MANUFACTURERS INSTRUCTIONS CONFLICT WITH INSTRUCTIONS BELOW, THE STRICTER INSTRUCTIONS SHALL GOVERN.

- Crane support columns shall be erected plumb not to exceed $\pm 3/8$ " from column base to crane beam elevation.
- Crane runway beams shall be installed to tolerances shown in Table A. below.
- Crane rails shall be aligned as shown in Figure J-1. Bearing pads under rails are highly recommended to reduce vibration and noise.

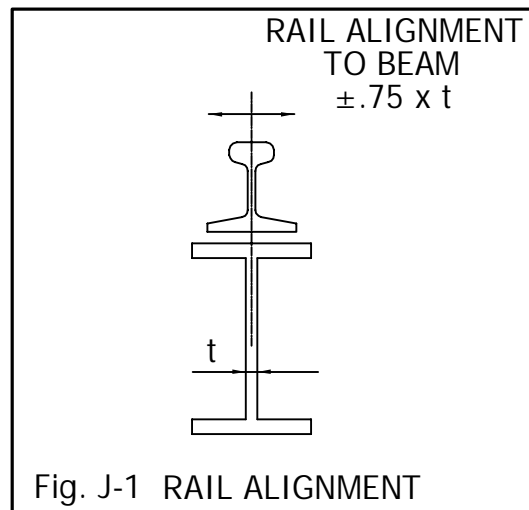

- Absolutely NO FIELD WELDING is allowed unless specifically shown on drawings or authorized by a registered engineer. Weld metal and base metal fatigue shall be considered in weld design.
- Crane operations cause vibrations in building components. Bearing pads, clamps, and ties (by others) may be required to minimize vibration noise.
- Construction tolerances in concrete elevations, steel fabrication tolerances, and erection tolerances may require field shimming of crane support beams to achieve proper elevation and alignment.

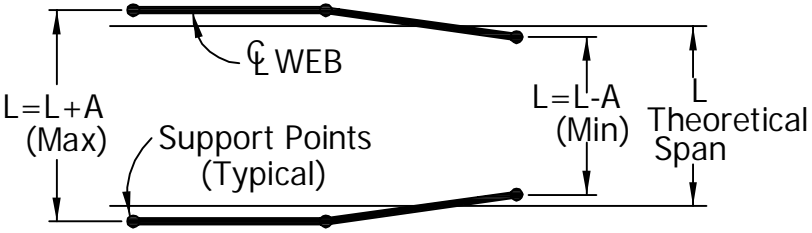
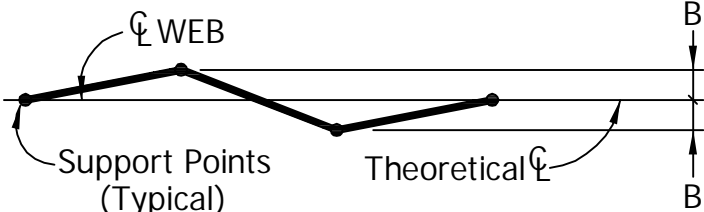
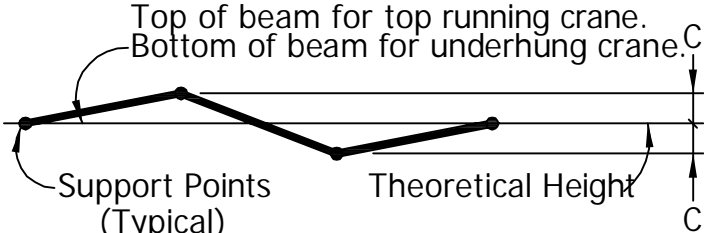
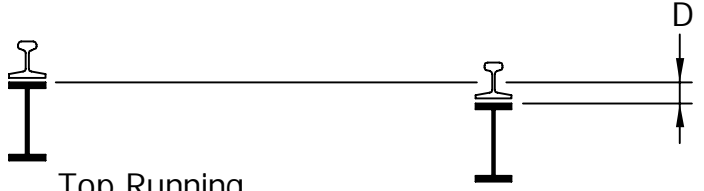
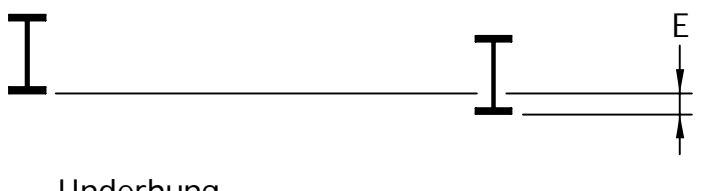
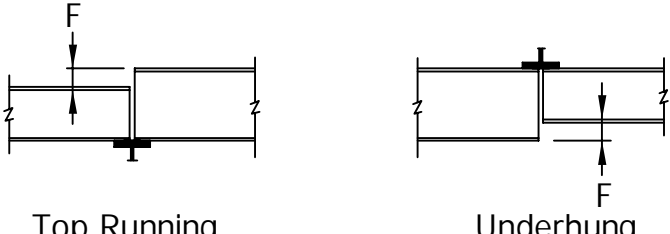
Item	<p style="text-align: center;">TABLE A CRANE RUNWAY BEAM ERECTION</p>	Tolerance	Maximum Rate of Change
Span	 <p>Diagram illustrating the span of a crane runway beam. It shows a top view of the beam with a centerline labeled ϕ WEB. The span is divided into two sections: a maximum span $L=L+A$ and a minimum span $L=L-A$. The theoretical span is also indicated. Support points are shown as typical.</p>	$A=3/8''$	1/4" per 20'
Straightness	 <p>Diagram illustrating the straightness of a crane runway beam. It shows a top view of the beam with a centerline labeled ϕ WEB. The beam is shown with a typical support point and a theoretical centerline. The tolerance is labeled B.</p>	$B=3/8''$	1/4" per 20'
Elevation	 <p>Diagram illustrating the elevation of a crane runway beam. It shows a side view of the beam with a top line labeled "Top of beam for top running crane. Bottom of beam for underhung crane." and a bottom line labeled "Theoretical Height". The tolerance is labeled C.</p>	$C=3/8''$	1/4" per 20'
Beam to Beam Top Running	 <p>Diagram illustrating the beam to beam top running configuration. It shows two beams with a top flange. The tolerance is labeled D.</p>	$D=3/8''$	1/4" per 20'
Beam to Beam Underhung	 <p>Diagram illustrating the beam to beam underhung configuration. It shows two beams with a top flange. The tolerance is labeled E.</p>	$E=3/8''$	1/4" per 20'
Adjacent Beams	 <p>Diagram illustrating the adjacent beams configuration. It shows two beams with a top flange. The tolerance is labeled F.</p>	$F=1/8''$	NA

Ref: AISC Design Guide 7



SHIMMING

Shimming may be necessary for runway beam height adjustments and vertical alignment. Shimming is considered to be part of erection process.

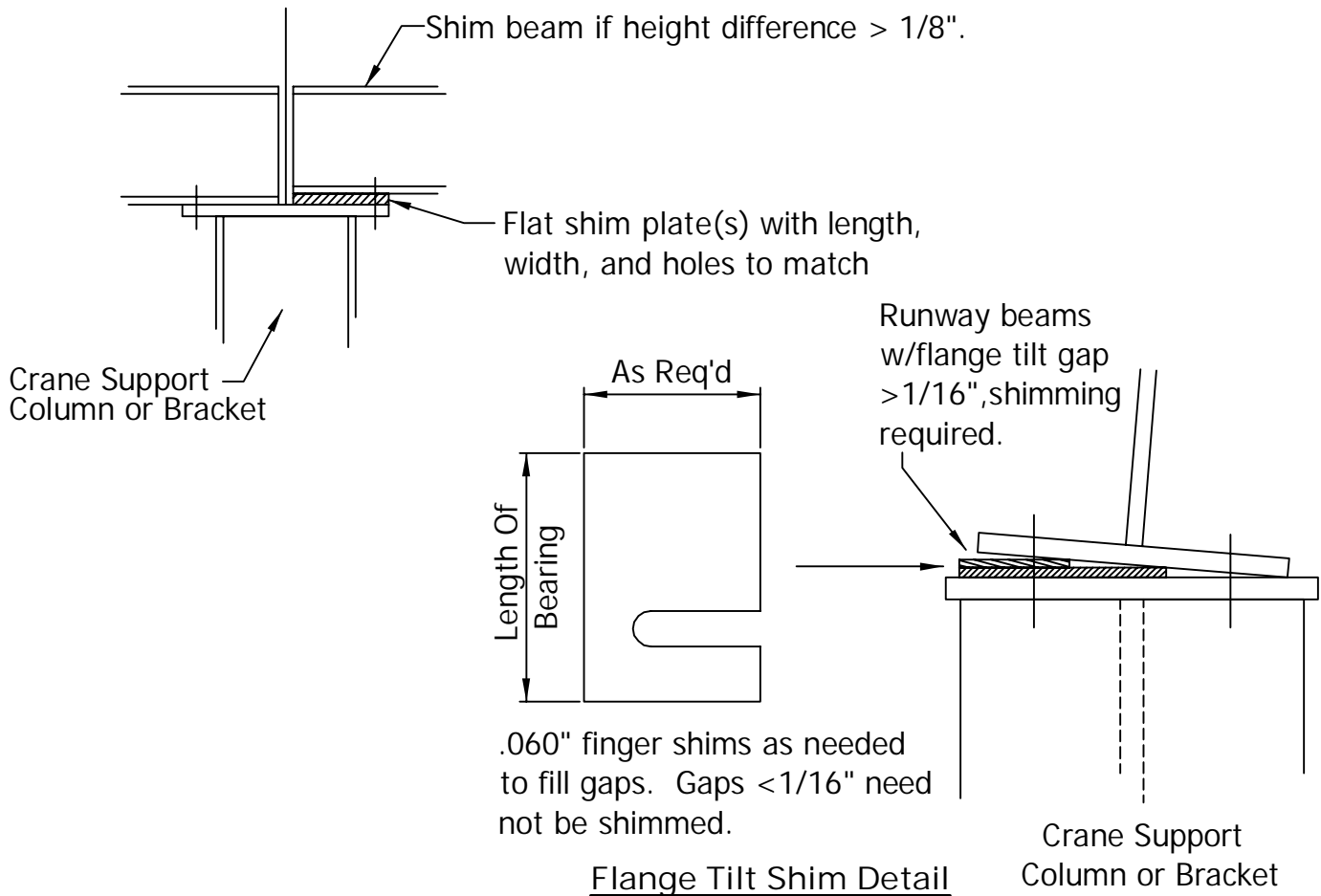

- Column bases are recommended to be double nut Anchor Rods and grouted after runway system is installed and leveled.
- See Chapter G for column base shimming for column bases.
- After all crane supports and rails are installed and all bolts are fully tightened to pre-tensioned load, ping thread with chisel to prevent nuts from loosening due to vibrations.

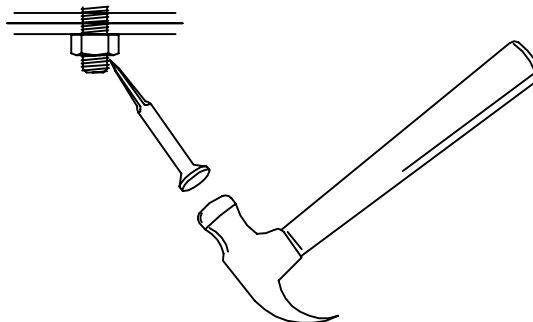

FIELD WELDING

Field welded joints must be done in strict compliance with BBNA erection drawings, and the appropriate welding specification shown below.

<u>IN USA</u>	<u>IN CANADA</u>
AWS D1.1- Structural Welding Code - Steel	CSA W59 - Welding Steel Construction (metal arc welding)
AWS D1.3- Structural Welding Code - Sheet Steel	AWS D1.3- Structural Welding Code - Sheet Steel

- Field welds must be done by welders qualified and approved for this type of welding, joints, and position required.
- In USA, the contractor is responsible for preparing a Welding Procedure Specification (WPS).
- In CANADA, the contractor is responsible for preparing Welding Procedure Data Sheet (WPDS).

WPS / WPDS forms and welder qualification certificates must be kept at the job site and made available upon request. In joints where the required procedure is not a pre-qualified joint, a Procedure Qualification Report (PQR) with appropriate testing must be prepared to qualify the weld procedure.

When specified on erection drawings, cost for field welding, qualification costs, inspection costs, or NDT tests are not the responsibility of BBNA.

BlueScope weld designs are based on the use of weld filler metal meeting the following:

- 70 ksi ultimate strength
- Min. 20 ft-lbs @ 0 degrees F impact strength
- Low-hydrogen process

WELDING THRU COATINGS

AWS D1.1 Sec 5.15 provides that: "... welded surfaces be free from loose or thick scale, slag, rust, moisture, grease, and other foreign material that would prevent proper welding or produce objectionable fumes. Mill scale that can withstand vigorous wire brushing, a thin rust-inhibitive coating, or antispatter compound may remain with the following exception: for girders in cyclically loaded structures, all mill scale shall be removed from surfaces on which flange-to-web welds are to be made."

Field welding thru BBNA standard shop coat and pre-galvanized steel is permitted. BBNA shop coat is a nominal 1.0 mil (.001") coating and galvanized surfaces (i.e. - up to G90 coating, .002") are considered to comply with the "thin rust-inhibitive coating" criteria anticipated by AWS.

Post fabricated hot dipped galvanized members with thicker coating (i.e. ->.002") has the potential of zinc entering the liquid weld metal causing cracking. Hot dip coatings must be ground off before welding.

Infrequent field welding of galvanized or shop coated members in open areas is not a health risk or hazardous issue. However vented welding hoods or other fume evacuation methods are recommended.

When field welding thru coatings, the coating is destroyed in the area of welding and must be touched up after metal has cooled.

INSPECTION OF FIELD WELDED JOINTS

Inspection shall be done as required by the local building official or project professional (AHJ). As a minimum, weld inspection tasks are as follows unless waived or modified by the AHJ. Field inspection costs are not the responsibility of BBNA.

Inspection Tasks

QC = Quality Control tasks are to be completed by the erectors QC Inspector (QCI). QC personnel shall be qualified to satisfaction of erector's QC program and as a minimum with any of the following;

- Associate welding inspectors (AWI) or higher per AWS B5.1, Standard for the Qualification of Welding Inspectors.
- Current or previous certification as an AWS Certified Welding Inspector (CWI) per AWS QC1.
- Current or previous certification as a CWB Welding Inspector per CSA W178.2
- An individual who, by training or experience, or both, in metals fabrication, inspection and testing, is competent to perform inspection work.

QA = Quality Assurance task are to be completed by a 3rd party inspection agency when a QA firm is required by AHJ or owner. The QA firm must be pre-approved by the AHJ. Quality Assurance Inspectors (QAI) shall be qualified to satisfaction of QA agency's written practice.

O = Observe. "Observe" is defined as; "Observe on a random basis. Operations need not be delayed pending these inspections.

P = Perform these tasks for each welded joint or member.

Table K-1

<u>Inspection Tasks PRIOR to Welding</u>	QC	QA
Welding procedure specifications (WPS or WPDS) available	P	P
Manufacturer certifications for welding consumables available	P	P
Material Identification (type/grade)	O	O
Welder identification system (the erector shall maintain a system by which a welder who has welded a joint can be identified)	O	O
Fit-up of groove welds (including joint geometry) <ul style="list-style-type: none"> • Joint preparation • Dimensions (alignment, root opening, root face, bevel) • Cleanliness (condition of steel surfaces) • Tacking (tack weld quality and location) • Backing type and fit (if applicable) 	O	O
Configuration and finish of access holes	O	O
Fit-up of fillet welds <ul style="list-style-type: none"> • Dimensions (alignment, gaps at root) • Cleanliness (condition of steel surfaces) • Tacking (tack weld quality and location) 	O	O
Check welding equipment	O	--

Table K-2

<u>Inspection Tasks DURING Welding</u>	QC	QA
Use of qualified welders	O	O
Manufacturer certifications for welding consumables available <ul style="list-style-type: none"> • Packaging • Exposure control 	O	O
No welding over cracked tack welds	O	O
Environmental conditions <ul style="list-style-type: none"> • Wind speed within limits • Precipitation and temperature 	O	O
WPS followed <ul style="list-style-type: none"> • Settings on welding equipment • Travel speed • Selected welding materials • Shielding gas type/flow rate • Preheat applied 	O	O

<u>Inspection Tasks DURING Welding</u>	QC	QA
Welding techniques <ul style="list-style-type: none"> • Interpass and final cleaning • Each pass within profile limitations • Each pass meets quality requirements 	O	O

Table K-3

<u>Inspection Tasks AFTER Welding</u>	QC	QA
Welds cleaned	O	O
Size, length and location of welds	P	P
Welds meet visual acceptance criteria <ul style="list-style-type: none"> • Crack prohibition • Weld/base-metal fusion • Weld profiles • Weld size • Undercut • Porosity 	P	P
Arc strikes	P	P
k-area. When welding in k-area of hot rolled shapes, visually inspect the web k-area for cracks within 3" of weld	P	P
Backing removal and weld tabs removed (if required)	P	P
Repair activities	P	P
Document acceptance or rejection of welded joints	P	P

Non-Destructive Testing (NDT)

NDT testing of field applied welds (other than visual), when required, shall be performed by QA Agency (3rd party) by qualified NDT personnel for the type of NDT specified.



BUTLER MANUFACTURING™

P.O. Box 419917 Kansas City, MO 64141-6917

© All rights reserved. A division of BlueScope Buildings North America, Inc.