

INDEX

1.0 Introduction

1.1 General 1-1
 1.2 Roof Performance..... 1-1
 1.3 Clean the Seams 1-1
 1.4 When to Seam 1-1
 1.5 Temporary Seaming..... 1-1

2.0 SEAMING EQUIPMENT

2.1 Specialized Seaming Tools 2-1
 2.2 Seaming Tool Source 2-1
 2.3 Seaming Kit 2-1
 2.4 Receiving and Shipping 2-2
 2.5 Handling and Storage 2-2
 2.6 Electrical Requirements 2-2
 2.7 Electrical Service and Cords..... 2-2

3.0 SEAM TYPES

3.1 General 3-1
 3.2 **RollLok™** Seam..... 3-1
 3.3 **TripleLok™** Seam..... 3-1
 3.4 **QuadLok™** Seam 3-1

4.0 CHECK PANEL ASSEMBLY

4.1 Sidelap Fit-up..... 4-1
 4.2 Seam Damage 4-1

5.0 MANUAL SEAMING TOOL OPERATION

5.1 Tool Orientation to Seam 5-1
 5.2 Forming the Seam 5-2
 5.3 Tool Position at End of Roof Panel 5-3
 5.4 Tool Position at Roof Panel Endlap 5-3
 5.5 Tool Position at Panel Clips 5-4
 5.6 Checking the Finished Seam 5-4
 5.7 QuadLok Manual Hand Crimper 5-5
 5.8 Hand Forming the QuadLok Seam 5-5
 5.9 Checking the Finished Seam 5-5

6.0 OPERATING THE MOTOR SEAMING MACHINE

6.1 Seaming Machine & Nomenclature 6-1
 6.2 Machine Orientation to Seam 6-1
 6.3 Machine Position on Roof Panel..... 6-2
 6.4 Running the Machine 6-3
 6.5 Stopping the Machine 6-3
 6.6 Un-locking the Machine 6-3
 6.7 Checking the Finished Seam..... 6-3

7.0. Motor Seaming Machine Maintenance

7.1 General 7-1
 7.2 Seaming Rolls..... 7-1
 7.3 Cooling Vents..... 7-1
 7.4 Grease Zerks 7-1

1.0 Introduction

1.1 General

The seaming guide is provided by **“Company Name”** to you the customers and erectors as the recommended procedures for the correct seaming of the **“Company Name” TS-324** Standing Seam Roof System.

This guide is intended to be used with the **“Company Name” TS-324** Standing Seam Roof System Installation Guide and the project’s erection drawings.

The erection drawings govern the specific seam requirements. In case of conflict between this installation guide and the erection drawings, the erection drawings will have precedence.

The customer is responsible for proper seaming of the roof in accordance with the erection drawings and this seaming guide, and in accordance with good engineering and construction practices.

The customer must take the responsibility for selecting a competent erector, insist that the work be performed

by qualified and experienced standing seam metal roof installers, insist that the erector take time to study and understand this guide, then assure that the erector correctly follows the guide’s instructions.

“Company Name” does not guarantee and is not liable for the quality of erection. **“Company Name”** is not responsible for building defects that may be attributed to improper erection or the negligence of other parties.

The following seamer equipment depicted in this manual is for seamers manufactured, provided and serviced by an approved supplier and are the only seamers approved to be used on **“Company Name”**’s **TS-324** standing seam projects.

Clarification concerning the **“Company Name”** roof installation and seaming should be directed to the **“Company Name”** Customer Service Manager. Contact the **“Company Name”** Office:

“Company Name”
Address and Phone

1.2 Roof Performance

The roof panels must be correctly seamed before the roof system can provide its designed wind load and weather resistance capability. This means that an un-seamed or

improperly seamed roof is subject to wind load failure and/or weather resistance failure.

1.3 Clean the Seams

The roof panel seams must be thoroughly cleaned of abrasive dirt or dust that can cause scuffing or scratching of the seam surface. The roof panel seams must be cleaned

of grease or other contaminants which can cause seaming machine slippage and marking of the seam surface.

1.4 When to Seam

Whenever possible, the installed roof panels should be seamed at the finish of each days work. If high wind or

rain/snow conditions are imminent, the installed roof panels **must be seamed** before such conditions occur.

1.5 Temporary Seaming

On roofs requiring **TripleLok** and **QuadLok** seams, it may not always be practical or feasible to motor seam the roof panels until after the roof installation is completed. Motor seamed roof panels are difficult to reposition or replace and seaming machines may not always be available during the entire roof installation period.

Since temporary seaming is a practical approach, it would be advisable to buy several hand seamers to keep for use on a job by job basis. There will be a hand seamer sent with each motorized seamer order, how ever its arrival to the jobsite is usually too late in the sheeting process to insure against any sudden weather changes or safety issues...

In such cases, it may be desirable to temporarily **RollLok** seam the roof panels at the panel ends, clips and end laps with the manual seaming tool, then later complete the seaming with the motor seaming machine.

Important: Any temporary **RollLok** seaming must be approved by the project’s designer.

2.0 SEAMING EQUIPMENT

2.1 Specialized Seaming Tools

The seaming of the “**Company Name**” roof panels require special seaming tools which are available only through the “**Company Name**” or the approved seamer supplier.

Caution: The use of other or unapproved seaming equipment may result in faulty and/or damaged seams and will invalidate the roof system’s material and performance warranties.

2.2 Seaming Tool Source

The seaming tools are provided by “**Company Name**” in accordance to the terms and conditions of the “**Company Name**” **TS-324** Roof System seamer rental or purchase contract.

Contact the approved seamer company’s Customer Service Department to arrange the scheduling, delivery and return of the seaming tools.

2.3 Seaming Kit

The seaming equipment will normally be provided as a seaming kit. The seaming kit will consist of the following:

- a. Seaming Kit Chest (contains and protects the seaming tools during shipment and storage).
- b. Motor Seaming Machine (provided only for **TripleLok** or **QuadLok** seaming)
- c. Return shipping documents
- d. Repair parts, hex and end wrenches
- e. Seaming Guide.
- f. TripleLok Manual Crimping Tool
- g. QuadLok Crimping Tool (when required)

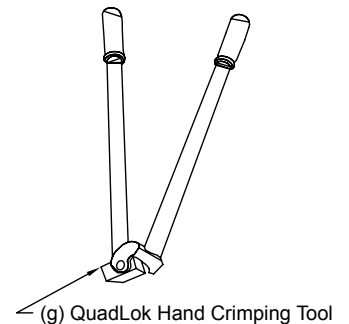
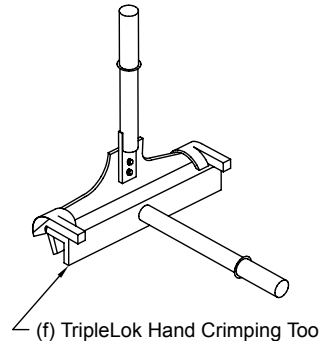
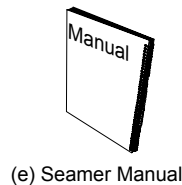
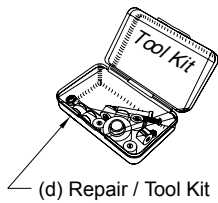
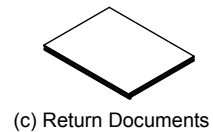
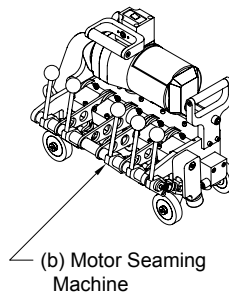
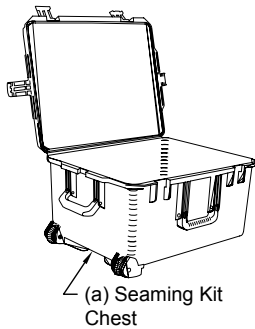

2.0 SEAMING EQUIPMENT (Cont'd.)

2.4 Receiving and Shipping

Upon receipt of the seaming kit, and before signing the shipping receipt, verify that the seaming kit is received in good condition without damage or loss of contents.

If there is damage or loss of contents, immediately file the claim with the shipper and notify Seamer Supplier for replacement instructions.

Upon completion of the roof seaming, promptly return the seaming kit to Seamer Supplier in accordance with the instructions on the return shipping documents. The return shipping documents are provided in the seaming kit. All materials must be returned (even worn rollers) intact and failure to do so will result in a charge for missing items.

2.5 Handling and Storage

Provide safe and secure handling of the seaming tools when in use.

The machine may be too heavy to safely carry up a ladder. Always hoist the machine onto the roof with proper lifting equipment or with a proper sized rope/tether tied or hooked securely to the machine's lifting eye.

At the days end or when the seaming tools are not in use, they must be stored in the seaming kit chest and the chest secured in a safe and dry area. The seaming tools must be cleaned and dried before storing.

2.6 Electrical Requirements

The seaming machine motor requires a minimum electrical power supply of 20 amp @ 120 Volt @ 60 hz AC.

2.7 Electrical Service, Cords and Safety

The electrical service and the electrical cords to the seaming machine must be of sufficient capacity to provide the full 20 amp @ 120 Volts **at the seaming machine**. If other tools or equipment are being used on the same service, the service and cord capacity must be increased accordingly.

Check that the electrical cord is of sufficient length to extend the full length of the area to be seamed without stress on the cord or its connections. Check that the path for the cord is clear and that the cord is clear of snagging on panel edges or entanglement into the seaming machine rolls.

Check that the power cords are fitted with the correct plug for safe and secure electrical connection to the seaming machine. Check that the power cords are properly grounded and that the service has a ground fault circuit breaker.

Caution: Low voltage due to insufficient service capacity, insufficient cord size or excessive cord length will cause overheating and burnout of the seaming machine's motor.

RECOMMENDED EXTENSION CORD SIZE				
Distance (Ft)	0 - 50	50 - 100	100 - 200	200 - 300
Wire Gauge	12	10	8	6

3.0 SEAM TYPES

3.1 General

The “**Company Name**” TS-324 Standing Seam Roof System has three seam type options. The project’s design and roof performance requirement’s govern which seam type is required.

Different seam types may be required on specific areas of the same roof. In all cases, refer to the erection drawings to determine the required seam type and location.

3.2 RollLok™ Seam

The **RollLok** Seam requires seaming the roof panels with the manual crimping tool only at the panel clips, at the eave and ridge ends of the roof panel, and at the endlaps.

The motor seaming machine is **not** required for **RollLok** seaming.

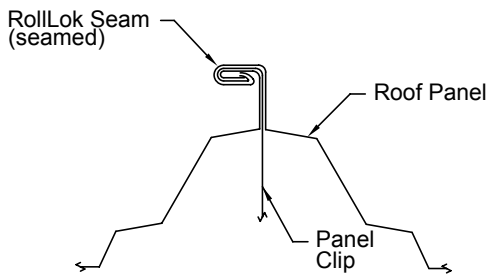

@ Panel Clips & Panel Ends

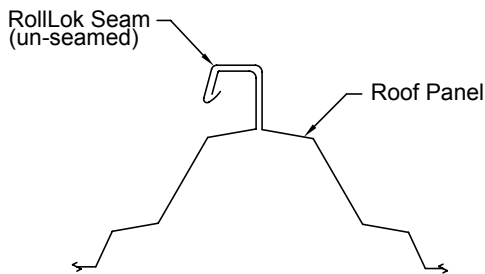

Between Panel Clips & Panel Ends
(No Mechanical Seaming Required)

3.3 TripleLok™ Seam

The **TripleLok** Seam requires seaming the roof panel with the TripleLok manual crimping tool at the eave, ridge end

of the roof panel and at the endlaps. Then seaming the full length of the roof panels with the motor seaming machine.

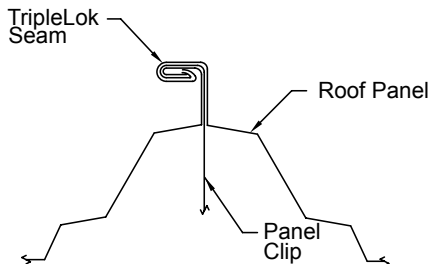

@ Panel Clips

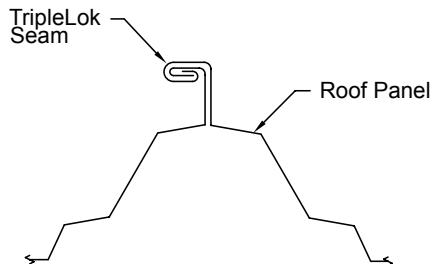

Between Panel Clips

3.4 QuadLok™ Seam

The **QuadLok** Seam can be completed in one pass. The starting point must be hand seamed with both the TripleLok and QuadLok hand crimper. Endlaps, eaves, ridges and

clips can be crimped with the TripleLok crimper ONLY if conditions warrant. **Never** use the QuadLok hand crimper anywhere other than the starting end of the panel.

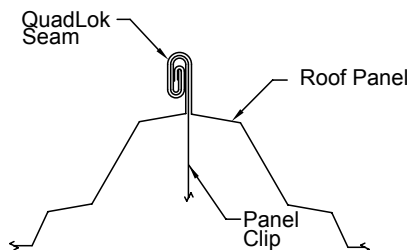

@ Panel Clips

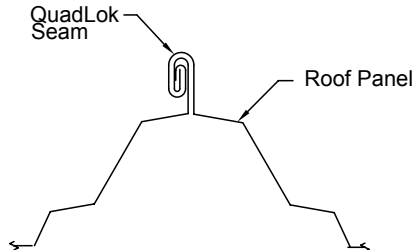

Between Panel Clips

4.0 CHECK PANEL ASSEMBLY

4.1 Sidelap Fit-up

Before seaming, inspect the full length of each roof panel sidelap. Check that the male and female are fully nested and the lip at the panel's male edge is enclosed by the hook of the adjacent panel's female edge.

Any conditions where the male and female are not fully nested or the male lip is not positioned inside of the female hook **must be corrected** before attempting to seam the roof panels.

Caution: *Faulty seaming may occur where the male lip is not enclosed by the female hook and when the male and female are not fully nested. Such faulty installation can result in seaming difficulty and objectionable seam appearance. In severe cases reduction in roof performance specifications..*

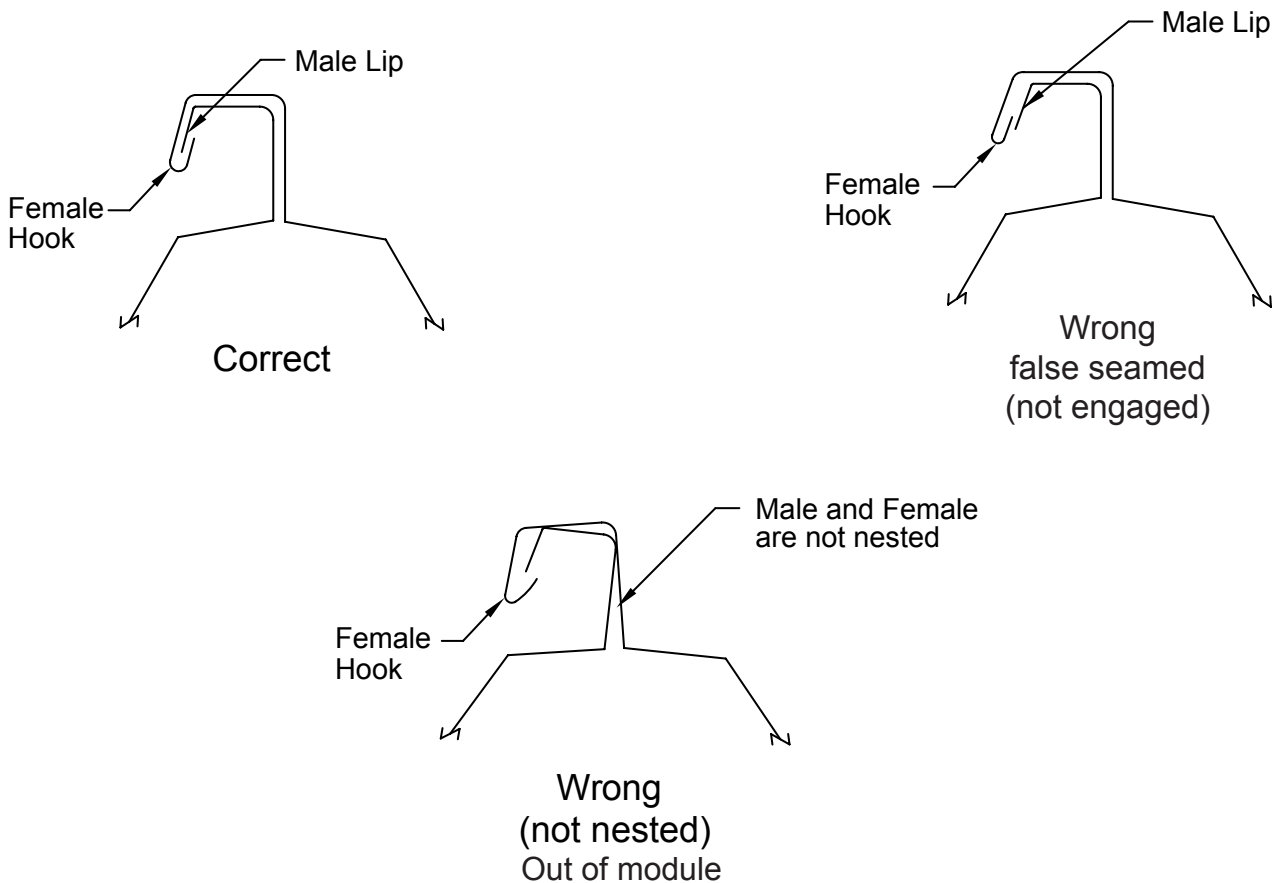

4.2 Seam Damage

Before seaming, check that the male and female edges are not kinked or otherwise distorted. **Any such distortions must be corrected before attempting to seam the roof panels.**

5.0 MANUAL SEAMING TOOL OPERATION

5.1 Tool Orientation to Seam

Orient the tool to fit correctly onto the roof panel seam as shown. The stationary handle must be in the horizontal position and the operating handle must be rotated up to the open position.

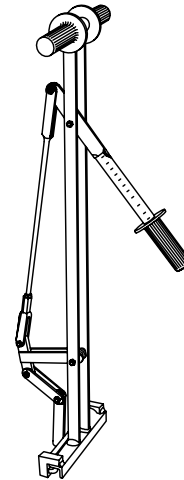
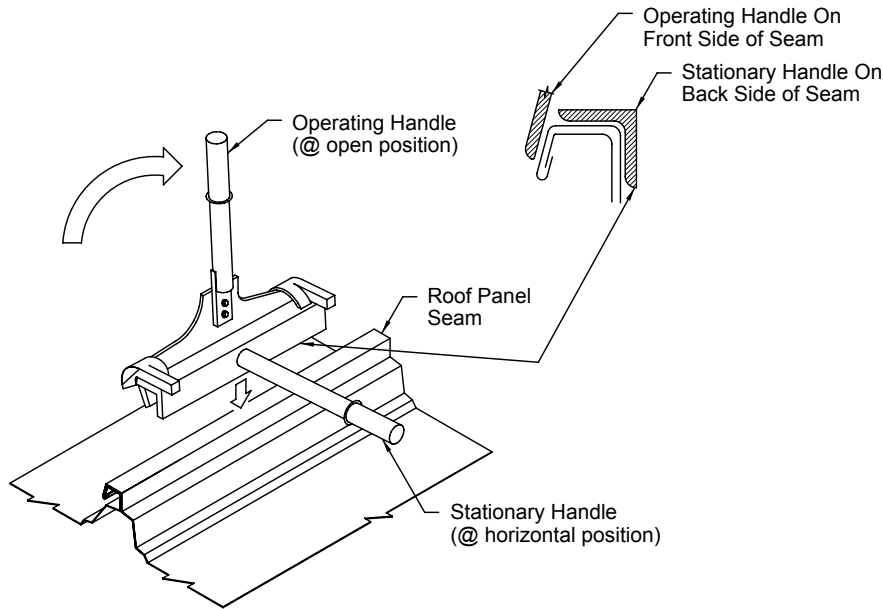

OPTIONAL: TripleLok Stand-up Hand Crimper Tool

5.0 MANUAL SEAMING TOOL OPERATION (Cont'd.)

5.2 Forming the Seam

When the tool is correctly positioned on the panel, push the stationary blade down solidly against the top of the

seam. While holding the stationary handle in the horizontal position, rotate the operating handle down to the horizontal position. This will form the seam.

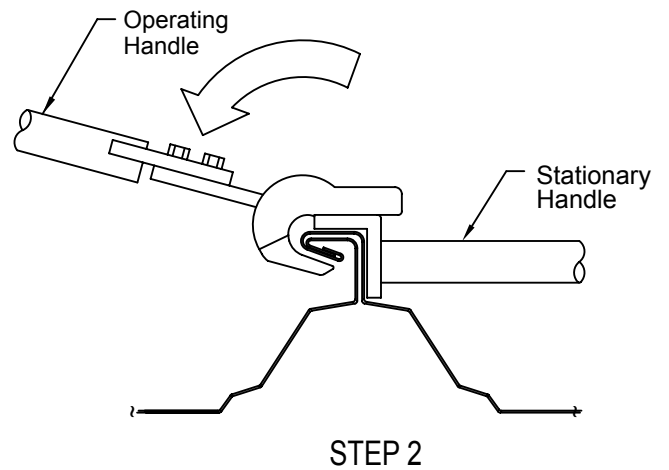
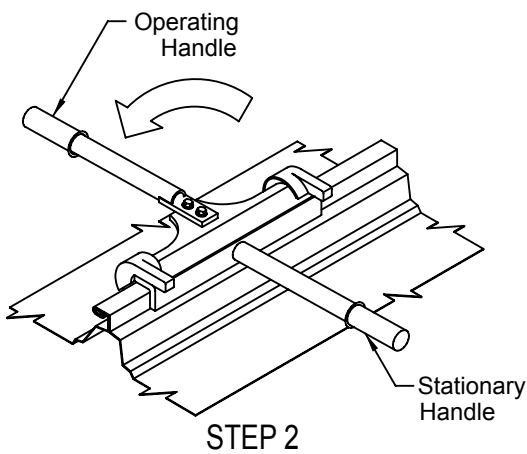
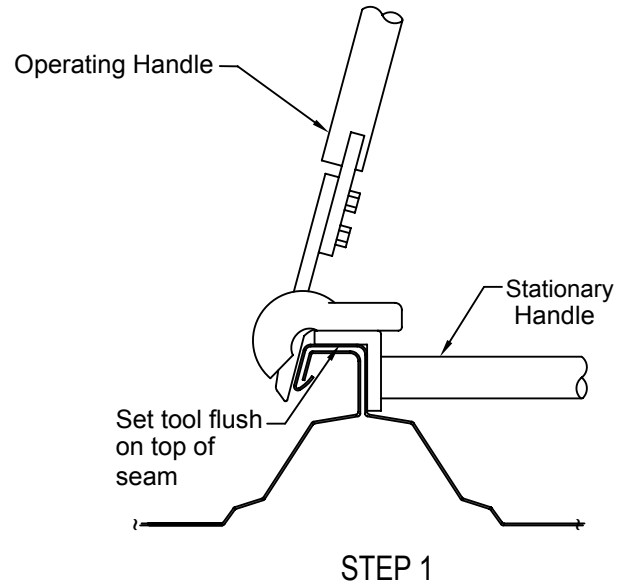
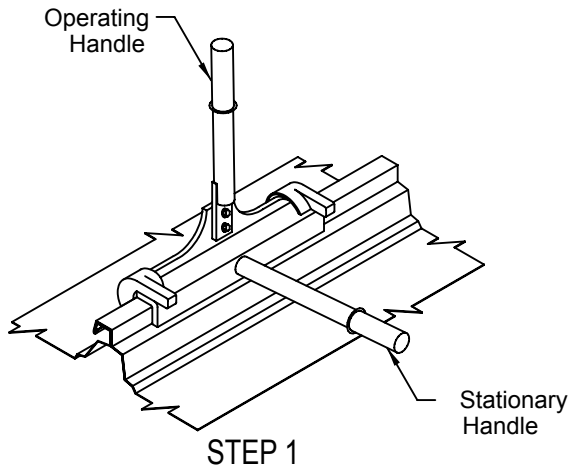

5.0 MANUAL SEAMING TOOL OPERATION (Cont'd.)

5.3 Tool Position When Hand Crimping at the End of Roof Panel

When hand crimping at the eave or ridge end of the roof panel, the seaming must be done in two steps.

For the **second step**, position the end of the crimping tool flush with the end of the roof panel and hand crimp that area.

For the **first step**, position the end of the seaming tool at 6" from the end of the roof panel and hand crimp that area.

When building a crimped section for starting the mechanical seamer, the crimped section should be approximately 18" long.

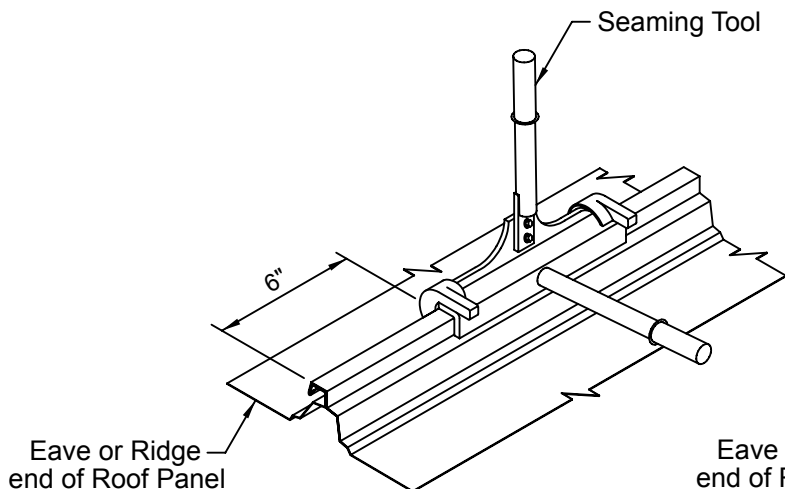

STEP 1

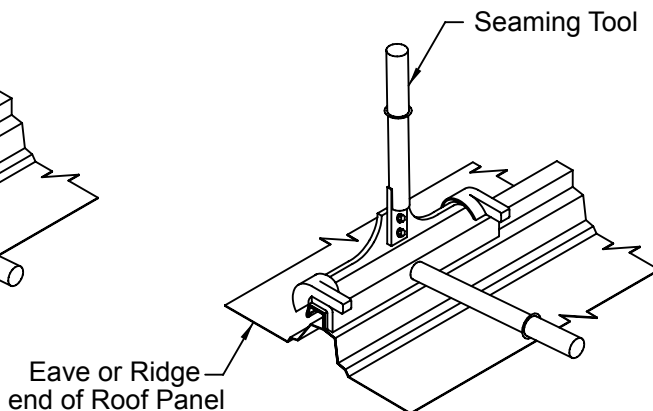

STEP 2

5.4 Tool Position at Roof Panel Endlap

When hand crimping at a roof panel endlap, the seaming must be done in two steps.

For the **second step**, position the end of the tool 3" uphill from the edge of the endlap and hand crimp that area. This is to allow the uphill "pig tail" sealant to properly flow and allow the motorized seamer to properly function at the lap.

For the **first step**, center the tool over the endlap and hand crimp that area.

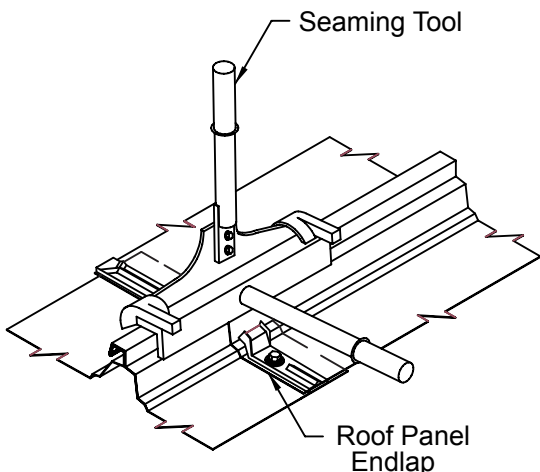

STEP 1

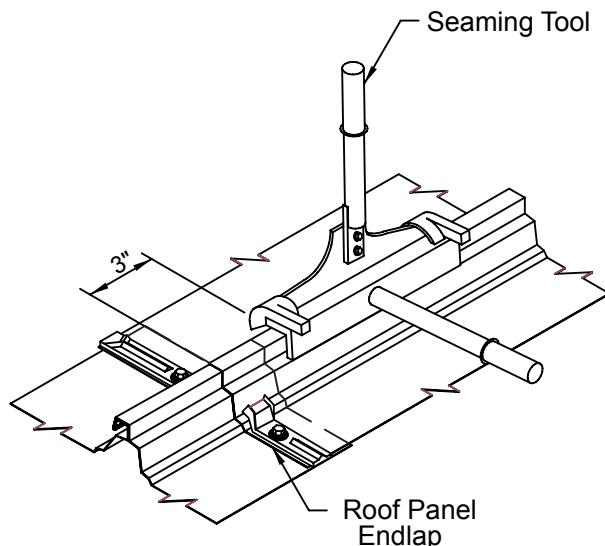

STEP 2

5.0 MANUAL SEAMING TOOL OPERATION (Cont'd.)

5.5 Tool Position at Panel Clips

When hand crimping at a panel clip location, center the tool over the panel clip and hand crimp that area. (A small tic mark should be made indicating the center of the clip tab during panel installation to make it easier to locate the clip for hand crimping.)

Hand crimp should include all of the clip and extend uphill and downhill of clip by a minimum of 6".

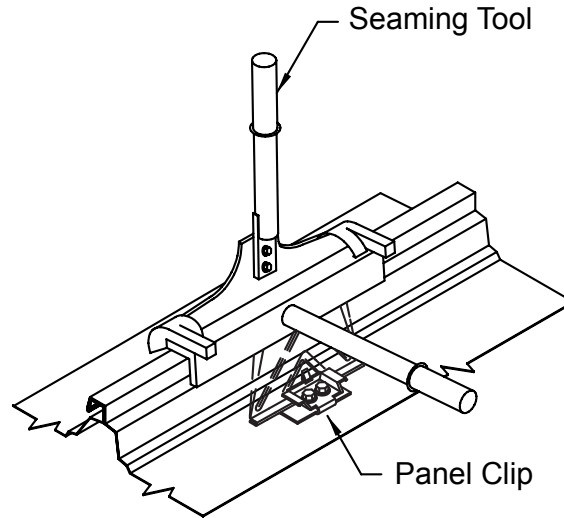

@ PANEL CLIPS

5.6 Checking the Finished Seam

Rotate the operating handle to the open position, remove the tool and check that the seam is correctly formed, as shown on the detail below.

Caution: If the manual seaming tool does not correctly form the seam, do not continue seaming but contact the seamer company for instructions.

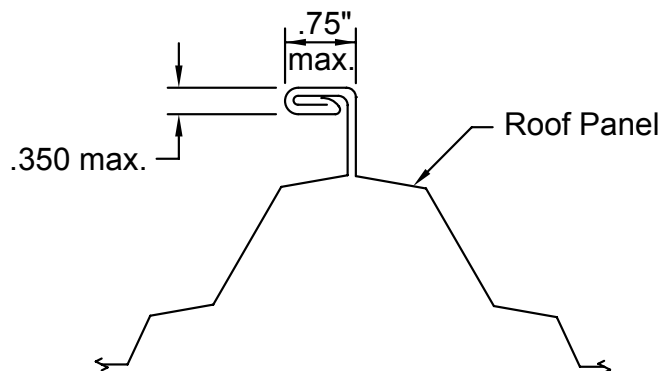

Finished TripleLok Seam

5.0 MANUAL SEAMING TOOL OPERATION (Cont'd.)

5.7 QuadLok Manual Hand Crimper

This crimper is only used at the start location on each seam for the **QuadLok** secondary motorized seamer.

Placing a QuadLok hand crimp in the middle of a seam **WILL** cause the seamer to derail, destroying the seam and possibly damage the seamer!

5.8 Hand Forming the QuadLok Seam

To begin, place the flat bar of the QuadLok crimper against the back side of the seam making sure the lip on the crimper extends over the TripleLok seam.

Crimp the end of the panel just enough to allow the last forming roll of the mechanical seamer to clamp on to the panel.

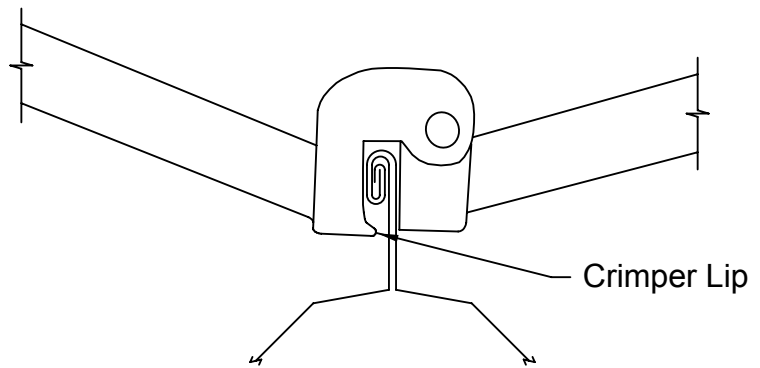
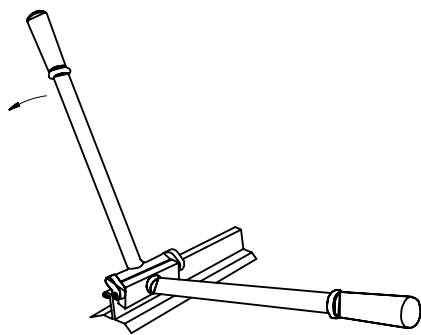

QuadLok Crimp the end of the panel only - Approximately 3"

5.9 Check the Finished Seam

Remove the hand seamer and check that the seam is properly made between steps.

Caution: If the seaming tool does not form a proper seam do not continue. Call the seamer supplier for assistance.

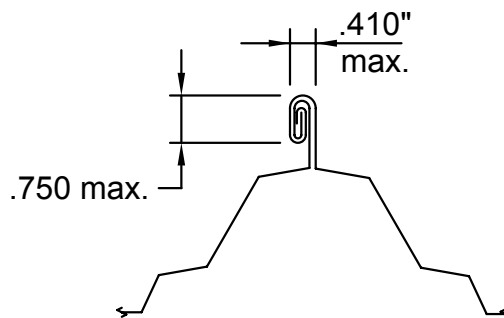

Finished QuadLok Seam

6.0 OPERATING THE MOTOR SEAMING MACHINE

6.1 Seaming Machine & Nomenclature

The following details identify the operational parts of the bi-directional (**TripleLok**) and one pass (**QuadLok**) motor seaming machines.

The cam follower is used only for **QuadLok** seaming and will be found on machines set-up for **QuadLok** seaming.

The motor seaming machine weighs at least 65 lbs. and can cause severe damage and injury if it falls and should be tethered at all times.

Caution:

- When starting and finishing the seaming machine at the edges of the roof, the operator and machines must be securely positioned and tethered so that he can safely lift the seaming machine on and off of the seam.
- When running the machine in the downslope direction, the seaming machine will have greater downhill inertia and coasting distance.
- When not locked to the seam, the motor seaming machine can freely roll on its wheels. Always secure the machine to prevent its rolling or sliding off the roof.

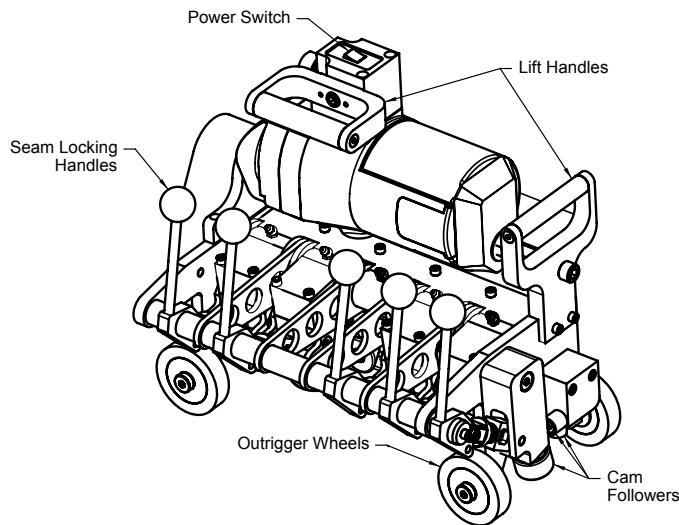

QuadLok Single Directional Machine

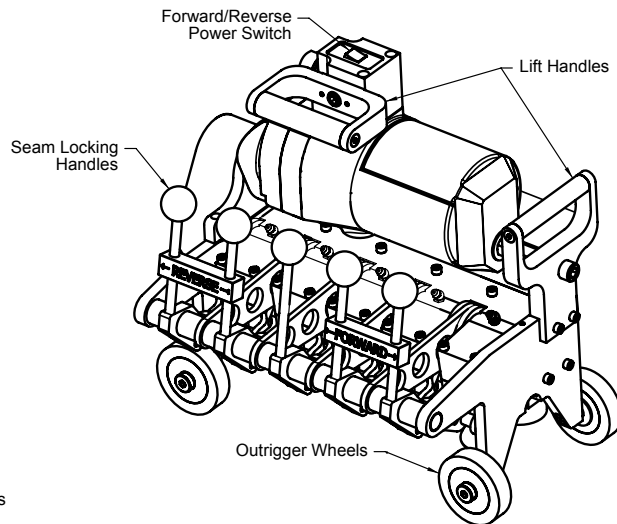

TripleLok Bi-Directional Machine

6.2 Machine Orientation to Seam

On roofs sheeted from left to right, the seaming machine will run from the ridge to the eave.

On roofs sheeted from right to left, the seaming machine will run from the eave to the ridge for one directional machines.

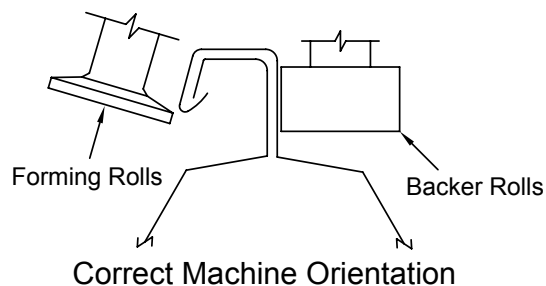
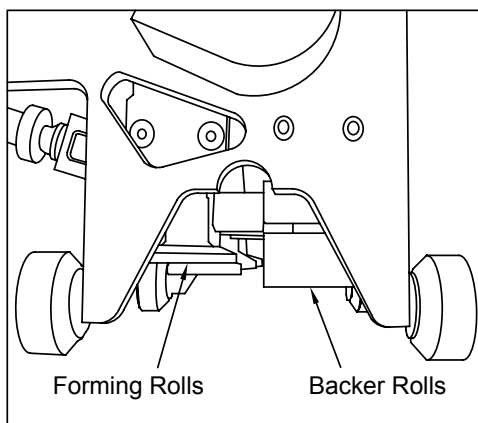

6.0 OPERATING THE MOTOR SEAMING MACHINE (Cont'd.)

6.3 Machine Position on Roof Panel

With the locking handles held up in the open position, set the seaming machine onto the starting end of the roof panel's seam over the hand crimped portion of the seam.

Roll the seaming machine forward or backward to align the center seaming roll over the TripleLok'd portion of the seam as shown in the detail below.

When the machine is in the correct position on the seam, pull the locking handle out to the locked position. The locking

handle should lock with minimal resistance starting with the center (TripleLok) handle when force is applied.

If the locking handle will not readily lock, roll the machine forward or backward slightly until a position is found where the locking handle will readily lock. If the locking handle still does not lock, check the hand-seaming to be sure it is in the proper form.

Once the center locking handle is locked, engage all the remaining handles. Check that all the forming rolls are properly engaged.

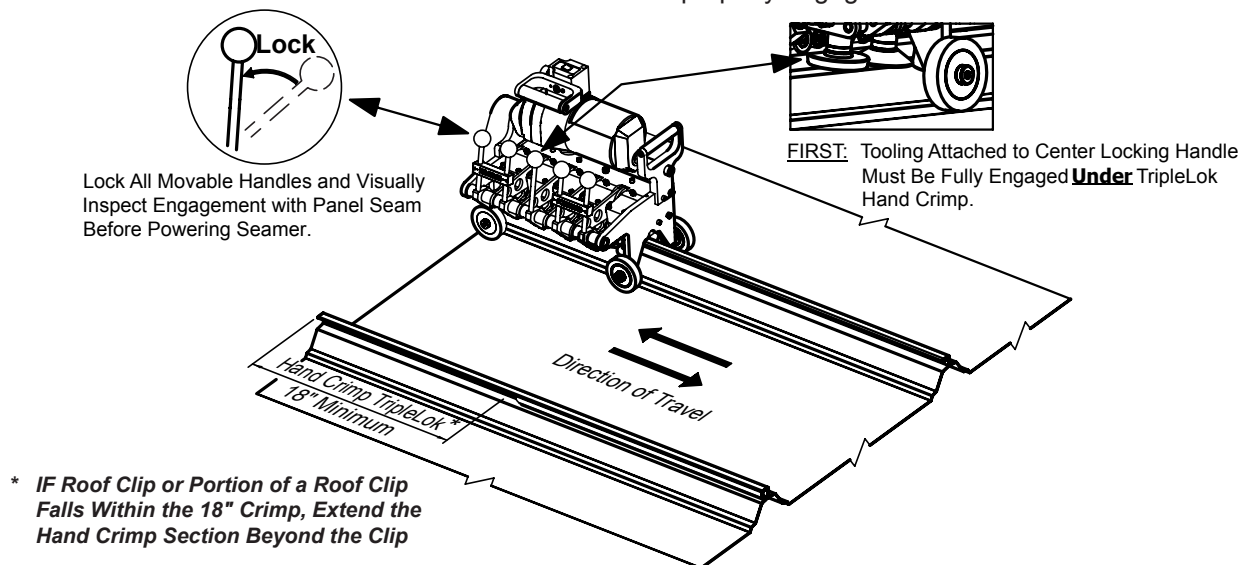

TripleLok Seamer - The TripleLok seamer can run one direction for that seam and can run in the opposite direction for the adjacent seam.

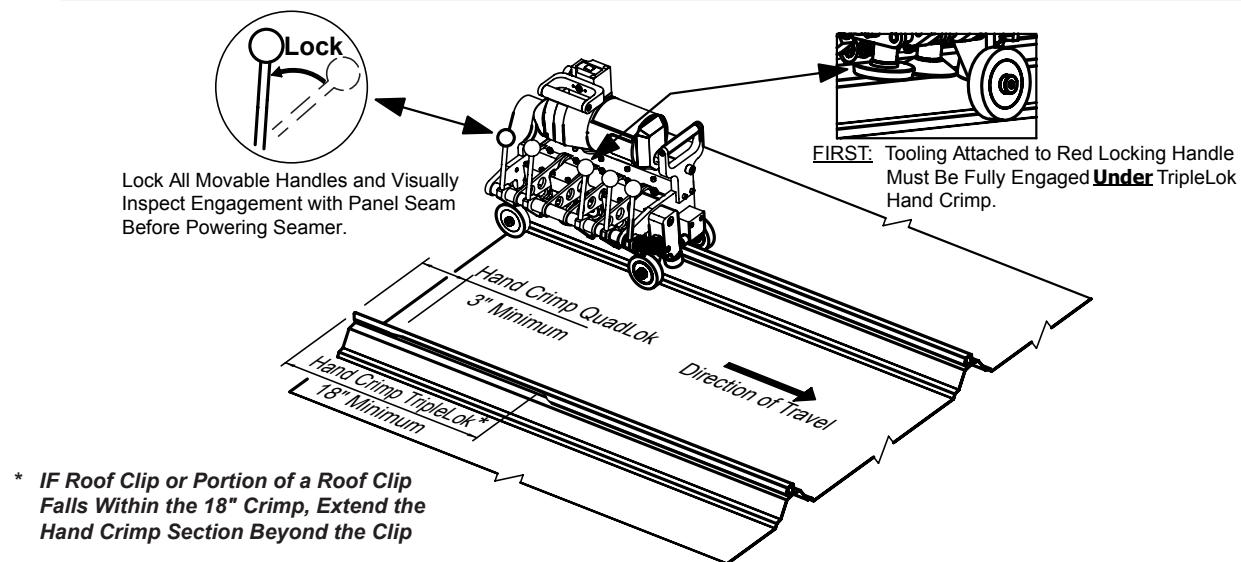

QuadLok Seamer - The Quadlok seamer can run in only one direction. Once one seam is completed, the machine must be returned to the starting position to start the next adjacent seam.

6.0 OPERATING THE MOTOR SEAMING MACHINE (Cont'd.)

6.4 Running the Machine

Check that the machine's path is clear of power cords, tools, debris, teather lines, etc.

Jog the machine forward a few feet and check the seam for proper forming.

Below are some examples of malformed seams. If any of these are observed, seaming should be immediately stopped. Contact the seamer supplier to determine the appropriate course of action to remedy the issue.

If the seam has a normal appearance, allow the machine to complete the run.

Continuously watch the machine and finished seam carefully for any indications of machine malfunction or faulty seaming.

Caution: On roofs with high stand-off clips, walking or standing on the panel being seamed can deflect the panel and cause the machine to tilt and affect the seaming operation.

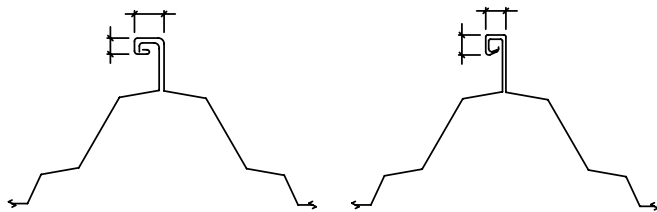

Out of Bounds Seam Element Lengths

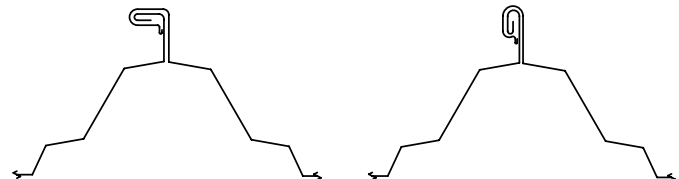

Hook Disengagement - Forced Out of Seam

6.5 Stopping the Machine

Stop the machine by turning off the machine's toggle switch.

Always allow sufficient space for the machine to coast after turning the machine off.

Do not run the machine into previously installed end dams or other obstructions.

Note: The **QuadLok** seam will stop just short of the installed end dams approximately 12". The seam should already be **TripleLok** hand seamed at the ridge prior to installation of the end dams. The end dams are designed for **TripleLok** seams only. This does not affect the performance of the roof system.

If the machine finishes at the low eave be sure seam is complete, this may require finishing with a hand crimper.

6.6 Un-locking the Machine

After the machine is turned off and has fully stopped, unlock the locking handle to the open position to disengage the machine from the seam.

Using the lift handle, the machine can be lifted from the seam.

If the machine must be stopped and removed before completing the seam, use a felt marker to mark the position of the machine's front wheel on the panel. The machine can later be repositioned on the mark to complete the seaming.

6.7 Checking the Finished Seam

At the completion of each seam, check the full length of the seam for any indications of faulty seaming. Refer to sections 5.6 & 5.9 for details of the correctly formed finished seam.

The seaming operation exerts high pressure bending forces on the seam. Under such conditions, minor burnishing,

pressure marks, and black oxide marking of the seam surface is normal.

Caution: Black oxide marking is often mistaken to be damage of the seam surface. Objectionable black oxide can be removed with mild cleaning solutions or solvents.

7.0 MOTOR SEAMING MACHINE MAINTENANCE

7.1 General

The motor seaming machine is a precision fabricated, high performance, portable roll forming machine. This relatively lightweight machine does the tough job of forming the extra strong **TripleLok** and **QuadLok** seams under often rugged field conditions.

Although designed for tough industrial use, the seaming machine requires proper maintenance to assure proper seaming and efficient, trouble free operation.

Caution: Failure to properly maintain the seaming machine as instructed below can result in faulty or damaged seams and costly break-down of the seaming machine.

7.2 Seaming Rolls

The seaming rolls require the following regular maintenance:

- a. Assure that the seaming machine's seaming rolls are free of dirt, grease, sealant, etc.

- b. Spray the seaming rolls with WD-40 (or equal) to prevent corrosion and minimize Galvalume build-up on the rolls.

- c. Assure that the seaming machine's seaming rolls are tight on their shafts. Check and tighten the rolls' retainer screws as necessary.

7.3 Cooling Vents

To prevent motor overheating, the motor has vents and an internal fan to provide a cooling air flow over the internal motor parts.

The cooling vents are located at the front and rear of the motor. Check frequently to assure that these vents are kept clean and clear of debris, stringing sealant, etc.

While the machine is running, never cover the machine or place it in a position where the cooling air flow to the vents will be restricted.

7.4 Grease Zerks

The seaming machine will be provided by the seamer supplier fully greased and lubricated. Grease zerks are for seamer supplier use only. Grease should never be added in the field unless instructed to by the seamer supplier.