



## Vacuum Systems: Understanding A Key Component of a Modern Power Plant

### Introduction

Vacuum systems have been used in the power industry for over 100 years. Today, vacuum equipment, such as liquid ring vacuum pumps, steam jet ejectors, and hybrid systems, are used for numerous applications in all types of power plants. The proper operation of a power plant's vacuum system is essential to the proper operation of the entire plant.

Plant personnel should have a good working knowledge of the theory and operating principles for vacuum equipment to assist them in proper operation of their vacuum systems. Despite the wide variety of applications and types of power plants in which vacuum equipment is used, the theory and principles of operation are the same for the basic equipment.

This article will explore some of the applications and equipment and will provide a thorough understanding of the theory and operating principles as well as tips for Proper operation and troubleshooting.

### I. Description of Applications in Power Plants for Vacuum Equipment

#### A. Main Condenser Exhaust Vacuum Equipment

Main condenser exhaust vacuum equipment is designed to continuously remove air and associated water vapor from the main condenser. The operating pressure of the venting equipment is designed per HEI *Standards for Steam Surface Condensers*, Section 6.0 or HEI Standards for Air Cooled Condensers, Section 9.2. This design pressure is critical for proper operation of the venting equipment and main condenser.

Venting equipment capacities are given in HEI *Standards for Steam Surface Condensers* Table 6, or HEI Standards for Air Cooled Condensers Table 5 as a function of total steam flow into the condenser and the number of exhaust openings. These venting capacities are based on the air vapor mixture at 1" HgA and a vent temperature of 71.5°F which is 7.5°F below the saturation temperature corresponding to the main condenser's design pressure of 1" HgA. If the design is required to be other than is specified in HEI standards, the user must include requirements in the specifications.

The full range of condenser operating pressures must also be taken into consideration in designing the venting equipment.

When ejector systems are used for this purpose it is common to use condensate from the main condenser as cooling medium in the ejector condensers. Liquid ring vacuum pump systems generally use the same closed cycle cooling water as the main condenser.

## B. Water Box and Circulated Water Pump Priming Equipment

Vacuum equipment is used to prime main condenser cooling water pumps by evacuating the water boxes to a vacuum level necessary to overcome the difference in head and remove air released from the cooling water during operation. This vacuum equipment is often also used to remove air pockets from water boxes.

Priming valves are often used between water boxes and the vacuum system to protect the vacuum system from being flooded with cooling water from the main condenser. It is also common to include a vacuum “reservoir” tank to dampen the effects of air surges.

## C. Steam Side Evacuation Equipment

This equipment, often referred to as hogs, is designed to quickly evacuate the steam side of the main condenser from atmosphere to a low pressure (usually 10" Hg Abs.) in order to allow the turbine to be brought online. The equipment is sized in accordance with the capacities in Table 8 of the *HEI Standards for Steam Surface Condensers* or in Section 9.6 of the *HEI Standards for Air Cooled Condensers*. These capacities are intended to provide an evacuation time of approximately 30 minutes. By their nature, these hogs are subject to intermittent service. Once evacuation is complete, the hogger is shut down and the main condenser exhauster operates to continuously remove air in-leakage.

- (1) Suction Pressure - This is determined by the amount of vacuum required to prime the system and the pressure drops between the hoggers and the system.
- (2) Capacity - This is determined by the volume of the system and the time allowed to reduce the pressure in the system.

Typically, a silencer is used at the discharge of a steam ejector hogger to reduce noise to acceptable levels while the equipment is operating. It is also common practice for liquid ring vacuum pump systems to use the standby pump in parallel with the main unit to achieve the hogging requirement. Occasionally there may be a separate hogging pump.

## D. Geothermal

The chief consideration in designing vacuum systems for this application is the large quantity of non-condensable gases contained in geothermal steam for the proper sizing and selection of liquid ring vacuums and steam jet ejectors. The amount and composition of non-condensibles vary from field to field, and must be specifically detailed by the user.

When vacuum pumps are used in this application, solubility of CO<sub>2</sub> and other gases must be considered.

When steam ejectors are used in this application, design consideration must be given to the presence of non-condensable gases in the motive steam. Furthermore, the corrosive nature of gases in geothermal steam makes material selection a very important aspect of system design.

## E. Nuclear

Nuclear power cycles contain additional non-condensibles such as oxygen and hydrogen as compared to those power cycles where air is the only non-condensable present in the condenser. Oxygen levels of 10-50 ppb over a fairly wide range of operation are to be expected (typical of Boiling Water Reactor (BWR) units). The selection of venting equipment to be used with these types of power systems should be carried out in accordance with *HEI Standards for Steam Surface Condensers*, Section 6.0 and Table 9.0, or *HEI Standards for Air Cooled Condensers*, Section 9.0 and Table 5 with an allowance for such gases specified.

## II. Types of Vacuum Equipment Commonly Used

### A. Steam Jet Ejectors

#### 1.0 Principle of Operation

The Standards for Steam Jet Vacuum Systems states “The operating principle of a steam ejector stage is that the pressure energy in the motive steam is converted into velocity energy in the nozzle, and, this high velocity jet of steam entrains the vapor or gas being pumped. The resulting mixture, at the resulting velocity, enters the diffuser where this velocity energy is converted to pressure energy so that the pressure of the mixture at the ejector discharge is substantially higher than the pressure in the suction chamber.”

An ejector (see sketch below) consists primarily of a body with a suction port, a venturi shaped diffuser tube, and a discharge port. Also included is a nozzle, usually of the converging diverging type, through which steam is admitted into the portion of the body referred to as the suction chamber.

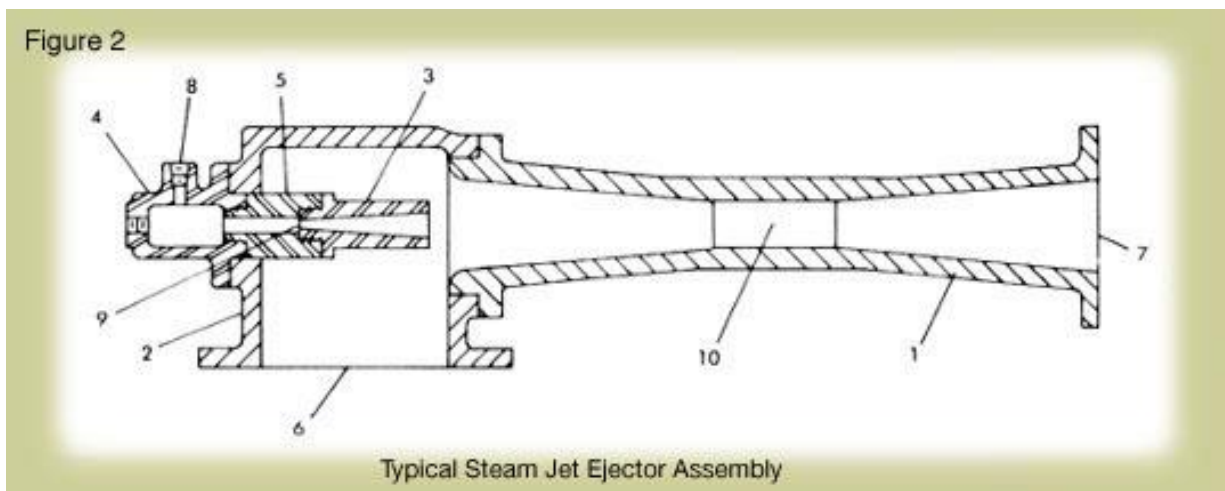

- |                        |                     |
|------------------------|---------------------|
| 1. Diffuser            | 6. Suction          |
| 2. Suction Chamber     | 7. Discharge        |
| 3. Steam Nozzle        | 8. Steam Inlet      |
| 4. Steam Chest         | 9. Nozzle Throat    |
| 5. Extension (if used) | 10. Diffuser Throat |

Ejectors can operate individually or can be arranged in a multistage configuration of several ejectors in series. Turbine condensers commonly utilize ejectors with twin elements of two or more ejector stages arranged for parallel operation. This allows continuous operation during service of the ejector system and also provides greater capability for gas removal at startup or at condenser operating conditions where high air in-leakage conditions exist.

The operating capability of an ejector is fixed by its dimensions and has practical limits on the total compression and throughput it can deliver. The ratio of the absolute pressure at the discharge port divided by the absolute pressure at the suction port is referred to as the compression ratio. This ratio is affected by the pressure of the motive steam that is used to operate the ejector, the vacuum that must be maintained at the suction inlet to the ejector, and the desired rate of motive steam consumption.

Two or more ejectors can be arranged in series for greater compression and twin elements can be provided in parallel for greater throughput. The capacity of an ejector is also a function of the physical proportions of the diffuser.

Ejectors are typically used to operate at a suction pressure below atmospheric and to discharge at atmospheric pressure or higher. Multiple stage and multiple element ejectors provide substantial performance capability and are selected to best subdivide the total compression among the several stages to meet the particular operating conditions. These units can be coupled with intercondensers and/or aftercondensers for the purpose of condensing as much vapor as possible from the preceding stage to reduce the amount of gas to be compressed by the next succeeding stage and to recover condensate. Condensers can be either surface type or direct contact depending upon requirements. It is necessary to provide means for draining condensers. Intercondensers, which operate under vacuum, require special consideration for drainage. Complete heat recovery of the ejector steam is essential. The heat must be recovered in a closed system to prevent absorption of oxygen by the condensate which is returned to the feed system.

## 2.0 Design Parameters

Steam jet ejectors are used to evacuate air and other non-condensable gases from power plant condensers which are saturated with water vapor. To reduce the water vapor content and resultant load on the ejectors, the temperature of the gas and water vapor mixture is reduced below the saturation temperature of the steam corresponding to the absolute pressure within the condenser. Ejectors are typically sized based on a gas and vapor inlet temperature equal to 7.5 °F below the saturation temperature corresponding to the design suction pressure of the venting equipment. Different sizing parameters may apply for geothermal and air cooled condenser applications.

Design parameters are a function of the requirements of the ejector application as previously described in section I of this article. The HEI *Standards for Steam Surface Condensers*, Section 6.0 and the HEI *Standards for Air Cooled Condensers*, Section 9.0, provide specific requirements for venting equipment (Section 6.0) which have been developed from the combined experience of the condenser and ejector industry.

Ejector systems are practical when motive steam is available. Typical motive steam pressures range from 80 to 300 psig. This supply pressure must be specified and should be the minimum maintained at all times. The size of a steam nozzle must be reduced as the operating steam pressure is increased, which increases the likelihood for fouling. The steam used may be slightly superheated to prevent nozzle erosion and the negative effects on ejector performance as a result of operation with wet steam.

The design of a system depends on the accuracy of the information that is provided. Complete information on the conditions at the suction of the ejector will be required. Mass flow and physical properties must be provided for each fluid component in the design load to the system. Pressure to be maintained at the suction flange must be specified along with the temperature of the load mixture. Pressure and temperature at the after condenser vent or ejector discharge are also required. If the ejector system requires surface inter- and or aftercondensers, then the maximum cooling water temperature, flowrate, and allowable pressure drop must be specified.

Evacuation time is sometimes an important consideration which needs to be specified. A hogger (a large capacity ejector provided in parallel) can be specified to achieve a vacuum level in a short period of time. The hogger typically moves a large volume of air and uses a large quantity of steam. As previously discussed, startup vacuum can also be achieved through the use of a twin element ejector system.

Construction standards are given in the HEI *Standards for Steam Jet Vacuum Systems*. Of particular importance are the materials of construction which must be specified for corrosion and erosion resistance concerns. Design standards such as TEMA and ASME may also be applied to inter- and aftercondensers.

The steam piping and ejector components which are exposed to high pressure steam should be capable of withstanding the maximum specified steam conditions. Test orifice connections should be provided to permit field testing after installation. Relief valves may be required for warning and protection in the event of over pressurization, which can result from steam being admitted to an ejector with discharge and inlet isolation valves closed.

### 3.0 Installation Requirements

The installation requirements of any power plant ejector system are site specific. Important to the operation of the ejector is the arrangement of the suction piping between the turbine condenser and ejector suction. The piping must be at least as large in diameter as the connection to the first stage ejector. To prevent pressure drop, this piping must be as short and direct as possible. Provision should be made so that low points in the piping can be drained back to the turbine condenser. Isolation valves should be provided for each element of twin element systems.

All piping must be supported to prevent the translation of excessive forces and moments on the ejector assembly. Cooling water inlet piping for surface inter and after condensers should be arranged and be as short as possible to prevent excessive pressure drop.

Condensers should be installed to allow for complete condensate draining. The intercondenser may be drained by a loop seal or liquid drain trap. The loop seal piping must be as straight as possible and installed so that no air pockets can be formed when feeding back to the turbine condenser. The after condenser is usually drained to the turbine condenser by means of a liquid drain trap. The draining and return piping arrangement of these lines are generally coordinated with the turbine condenser manufacturer. The aftercondenser atmospheric vent piping must be designed to minimize the back pressure imposed on the ejector system.

Motive steam piping should be appropriately sized and as direct as possible from the main steam line to keep the pressure drop to a minimum. The ejector steam supply line should be from the top or side of the main steam piping. A steam strainer, moisture separator, and pressure reducing valve, if supplied, should be located in this line and be as near as possible to the ejector. Flanged or union connections must be made as close to each ejector nozzle head in order that they can be readily removed for inspection. Adequate space should be allowed around each nozzle for easy removal. A reliable steam pressure gauge should be installed in the steam piping between the ejector and pressure control valve. Steam lines must be supported (and insulated if necessary) and drained with steam traps.

### 4.0 Operation and Maintenance

The two primary concerns for maintaining operation of steam ejectors are leak tightness and cleanliness. Condenser tubes should be inspected approximately every six months and cleaned as often as necessary. Steam strainers, ejector steam nozzles, and diffusers should be inspected at regular intervals and cleaned as necessary. To clean steam nozzles, it is recommended that the complete nozzle head assembly be removed and cleaned. At the same time, the steam piping should be thoroughly blown out, until all loose scale has been removed. It is advisable to switch elements at regular intervals to distribute wear, the element taken off line should be examined and cleaned if necessary.

All parts of the system under vacuum should be maintained tight at all times to prevent leakage of air into the system. Excessive air in-leakage will overload the ejector causing poor vacuum in the turbine condenser. Leaky condenser tube joints can easily be repaired by re-rolling the tube in the tube sheet. Many older condensers still in service contain packed tube joint ends and can simply be repacked or tightened. If leaks continue, the tube(s) should be replaced.

A source of dry steam at or slightly above design pressures must be available at the ejector nozzles at all times. In actual practice the steam pressure measured at the ejector nozzles should be maintained at least 10 psig. above the minimum operating pressure to allow for slight pressure fluctuations in the main steam supply line.

Operating a steam jet vacuum system at steam pressures lower than those specified in the system design will reduce stability. If moisture is present in the steam, a separator and trap should be used to improve steam quality to better than 99.5%. An ejector may work with as much as 2 or 3% moisture in the steam, but would then require greater design pressures.

Since the operating pressure of the intercondenser is sub-atmospheric (under vacuum), collected condensate must be continuously removed. This may be accomplished by gravity, through a liquid drain trap, a loop-seal tailpipe, or with the help of a condensate pump.

Be sure to consult the manufacturer's manuals for operating instructions.

## 5.0 Troubleshooting Tips

Malfunction of an ejector system like any other piece of plant equipment can be attributed to external as well as internal influences. Determining the cause of the problem should be done by qualified personnel using proper techniques, and test equipment.

External problems require locating the source. Examples are changes in service conditions requiring more demand on the ejector condenser cooling water supply or increases in average cooling water temperature especially during the summer. Also increased air in-leakage into the system or even changes in motive steam supply conditions due to poorly insulated steam lines and/or boiler loss in efficiency will impact the system. Steam quality is most important in its effect on ejector performance. Wet steam alters performance. It wears out ejector components, changing critical dimensions on nozzles, venturis etc. No ejector should ever be operated with steam quality below 97%; that is, with more than 3% water in the steam. High pressure steam can also be a problem; running ejectors at pressures substantially above design decreases capacity because of choking in the venturi. It is safe up to a certain percentage as associated with the design of the nozzle and is different for each manufacturer. High pressure steam to the ejector should always be throttled back.

Under normal operation air leakage into a turbine and condenser is often too low to be indicated by the air leakage meter supplied with the ejector system. The air leakage meter is intended to indicate measurable leakage. Air in-leakage is usually greatest when seals are not tight, and the turbine condenser is at low load. After determining that the correct cooling water flow, temperature, and motive steam conditions exist and that the pressure at the discharge of the final ejector stage is not excessive, determine whether the operational problem resides within the ejector system itself.

Internal problems require a step by step procedure in order to assess each component. The first step is to isolate the ejector by means of a "blank off" plate at the suction inlet of the first stage ejector, which is defined as the stage into which the vapor or gas being compressed first enters. With all units operating while the plate is in place, the ejector will evacuate the first stage suction chamber to the minimum pressure that the ejector is capable of producing. The following shut off pressure can be expected (each is approximate, and will vary with the system design):

- |                        |                            |
|------------------------|----------------------------|
| • Single stage ejector | 50 mm Hg. Abs.             |
| • Two stage ejector    | 4 to 10 mm Hg. Abs.        |
| • Three stage ejector  | 0.8 to 1.55 mm Hg. Abs.    |
| • Four stage ejector   | 0.1 to 0.2 mm Hg. Abs.     |
| • Five stage ejector   | 0.01 to 0.02 mm Hg. Abs.   |
| • Six stage ejector    | 0.001 to 0.003 mm Hg. Abs. |

If this test indicates that the ejector is operating at its approximate shut off pressure, then it can be assumed that the ejector will operate satisfactorily along its entire performance curve. Further troubleshooting would then be required on the vacuum system upstream to the ejector.

If the expected shut off pressure is not obtained or is unstable, then further troubleshooting should be confined to the ejector system. The most common method for determining leaks is the hydro test which should be done only after checking design specifications for allowable pressure and if the system can carry the extra weight of the water to perform the test.

If a hydro test cannot be utilized, a low pressure air test, using air pressurized to approximately 5 psig, can determine if the ejector system has a leak. Once again, system specifications should be checked to ensure that the unit will tolerate such pressure. During the test, a soap solution or spray should be applied to all joints, valve packings and other potential leak sites.

If an air leak is present, the soap solution will form a bubble over the leak. Another method to check for leaks while the unit is in operation is to apply shaving cream to all joints and potential leak points. The cream will be sucked into the opening to identify the leak source.

If the hydrotest, air, or vacuum test have not indicated any leakage, the next step is to check the internals of each component for damage or wear. Dismantle the ejector and check for deposits, scaling of internal parts, and/or wear in the nozzle and diffuser.

If the system uses multistage ejectors, begin with the final stage unit. Check the threads of the nozzle for telltale white or tan streaks, which indicate a steam leak through the threaded connection. Remove deposits from the suction chamber and make sure it is not cracked, rusted, or corroded. Shine a small light through the diffuser to make sure it is completely free from scale and is not pitted, grooved, or cut. After all stages and inter condensers have been cleaned, the throat diameters of the nozzles and diffusers should be measured as accurately as possible. Compare these with the original dimensions of the throat diameters, supplied by the manufacturer to determine wear.

If either diameter is larger than the original equipment specifications, calculate both original and present throat areas, and determine the percentage increase in areas.

If the percentage increase is greater than 7%, then the nozzle or diffuser will have to be replaced before satisfactory operation can be expected.

If the percentage increase in area is only 5%, replacement components should be ordered to restore original design performance.

## **B. Liquid Ring Vacuum Pumps**

### **1.0 Principles of Operation**

The liquid-ring vacuum pump is a specific form of rotary positive-displacement pump utilizing liquid as the principal element in gas compression. The compression is performed by a ring of liquid formed as a result of the relative eccentricity between the pump's casing and a multibladed impeller.\*

(\*For complete information on operating principles and design specifications, see the HEI *Performance Standards for Liquid Ring Vacuum Pumps*.)

The eccentricity results in near-complete filling, and then partial emptying, of each rotor chamber during every revolution. The filling and emptying actions create a piston action within each set of rotor or impeller blades.

The pump's components are positioned in such a manner as to admit gas when the rotor chamber is emptying the liquid, and then allowing the gas to discharge once the compression is completed. Sealing areas between the inlet and discharge ports are provided, to close the rotor areas, and to separate the inlet and discharge flows.

## 2.0 Design Parameters

### a. Main Condenser Exhaust Vacuum Equipment

- i. Suction Pressure/Temperature - Per the HEI *Standards for Steam Surface Condensers*, Section. 6.2, and the HEI Standards for Air Cooled Condensers Section 9.2 differentiate between “Electrical Generating Service” and “Pumps, Compressors, and Other Mechanical Devices” as far as establishing a design suction pressure. Basically the “Electrical Generating Service” is specified as a 1.0 inch HgA pressure unless the surface condenser has a lower design point. For the alternate applications, which generally appear in the private sector(Process Industries), the suction pressure becomes 1.0 inch Hg lower than the surface condenser design pressure with 1.0 inch HgA being a minimum level. Specific site considerations should be taken into account in arriving at the design suction pressure; that is, if the cooling water temperature can never be low enough to allow the Condenser to function at 1.0 inch HgA then a higher suction pressure can be selected.
- ii. Cooling water - The CW temperature associated with the condenser design point should be furnished so that the equipment can be designed properly. The cooling water may require special heat exchanger cold side materials.

Because of this, the chemistry of the water should be provided. Caution should be used when specifying materials to ensure that they will be compatible with the flow media.

- iii. Capacity - The HEI minimum recommended capacities can be found in HEI *Standards for Steam Surface Condensers*, Section 6.5, and the HEI Standards for Air Cooled Condensers Section 9.5. This capacity is based on the design steam flow to the condenser and the condenser design, including multiple shells. Additional capacity must be specified if the make-up must be deaerated in the hot well. Some Nuclear Plant applications require the addition of oxygen and hydrogen to the load gases leaving the Condenser. The capacities for Air Cooled Condensers may have to be adjusted based on larger volumes and the type of construction.

### b. Water Box and Circulated Water Pump Priming Equipment

- i. Initial Prime - Removing the air from the system to lift water up into the condenser before the circulating pumps are started.
  - A. Suction Pressure - This is determined by the amount of head required to prime the system and the pressure drops between the vacuum pump and the system.
  - B. Capacity - This is determined by the volume of the system and the time allowed to reduce the pressure in the system.
- ii. Continuous Prime - Removing the air liberated from the water during operation.



- A. Suction Pressure - This is dictated by the operating pressure in the water boxes or the pump eye and the pressure drops between the vacuum pump and the system.
  - B. Capacity - This is determined by the quantity and temperature of water being handled in the Condenser, and the lowest operating pressure in the water boxes or the pump eye.
- iii. Cooling Water - Because the cooling water temperature will have less impact on Priming Equipment than the Main Condenser Exhaust Vacuum Equipment, a closed cycle cooling water loop is usually considered as it will not force the use of exotic materials for the seal cooler heat exchanger. The system may also be run with a once through service water arrangement if the vacuum pumps are small and there is a source of clean water available. This will eliminate the need for a recirculated service water system and the associated maintenance.
- c. Shellside Evacuation Equipment (Hogger) - Removing the air from the system to allow the turbine and associated equipment to be brought on line.

### 3.0 Installation Requirements

The proper installation of a liquid-ring vacuum pump is critical to its subsequent operation and maintenance. The following installation guidelines are general recommendations that apply to nearly all types of liquid-ring vacuum pumps, but users should refer to the specific recommendations of each manufacturer to ensure the best performance.

As with any pump, care should be taken in unpacking the pump so as not to damage or misalign the assembly. For pump and motor units mounted on a baseplate, the unit should be lifted by the base only. Slings or hooks should not be attached to the pump or motor, since this can cause misalignment. Also, the pump should not be run until it is properly installed, nor should it be run without a sealing liquid.

If the pump has been shipped with a preservative coating on internal parts it should be flushed. If the pump is to be stored, care should be taken to prevent freezing of liquid inside the pump.

#### a. Setting up

Liquid-ring vacuum pumps are basically slow-speed, smooth-operating rotating devices. Nonetheless, it is important to ensure that the pump's frame or baseplate is mounted level and firmly anchored.

Pumps that are 50 hp and above are generally placed on a concrete pad and grouted. Smaller units may be mounted on existing floors and structures. All joints in piping, whether flanged or screwed, should be free of strain and checked for leaks prior to start-up.

Normally, pumps that are supplied with gears or are direct coupled to motors are aligned and/or test-run in the factory prior to shipment. However, because of unforeseen forces and moments imposed on the pump during shipment and installation, it is necessary to check the coupling's alignment prior to startup. To do this correctly, the guidelines of the coupling manufacturer should be followed.

#### b. Piping the service liquid

The working principle of the liquid-ring pump is dependent upon a continuous supply of clean service liquid. This liquid enters the pump through a connection on the casing and is discharged from the pump, along with the gas.

Three basic piping arrangements for the service liquid can be used for vacuum pump applications: once through, partial recovery, and closed loop. All these arrangements have four elements:

- A source for the seal
- A regulating device, to control the flow of liquid, if required
- A means of stopping the flow when the pump is shut off
- A means of separating the gas-liquid exhaust mixture

With partial recovery or closed loop arrangements, the service liquid level in the system should be at, or slightly below, the centerline of the pump shaft. Provisions may also be made for high-level overflow and low-level makeup on total recovery systems. These level controls help prevent the starting of the pump with the casing full of liquid, since this could overload the motor and damage the pump.

In fact, liquid-ring vacuum pumps in any piping arrangement should not be started with a full casing of service liquid. Thus, provisions are normally made to drain the pumps in the event they become flooded. These provisions may vary somewhat from one manufacturer to another.

Many liquid-ring vacuum pumps that incorporate a standard packing or gland arrangement for shaft sealing are also fitted with lantern rings and a gland connection provided for flush liquid. A suitable source of flush liquid must be provided, approximately 5 psig above the operating pressure. A common supply for both the service liquid and the gland cooling is normally used. If a suitable source of flush liquid is not available, liquid may be taken from the pump casing. Be sure to check with pump manufacturer for specific recommendations. If mechanical seals are employed, a supply of cooling and flush water may also be required.

### c. Piping

The suction and discharge lines should be the same size as the pump connections.

Ideally, the discharge line from the pump to the separator should be at as low an elevation as possible. However, if it is necessary, a discharge leg can be used with minimum elevation above the pump's discharge flange. Too high an elevation in the discharge line can cause a back pressure on the pump, overloading the motor and affecting the pump's capacity.

The seal-water supply piping should be the same size as the connection on the pump. For fully recirculated seal systems that do not use a recirculation pump, a larger pipe size is often used to reduce the pressure drop.

Remove the protective coverings from the pump openings just before connecting the pipe work. Check that all foreign matter, such as welding slag, nuts, bolts, rags and dirt, have been thoroughly cleared out of pipe work before connecting to the pump.

When connecting the pipe work, check that the flanges fit easily without strain, and that the flange holes are in perfect alignment. The flange gaskets must not protrude into the interior bore of the pipe or pump flange. All pipe work must be supported independently of each side of the pump, and must fit easily without transmitting strain to the pump casing. It is recommended that during the first 100 hours of operation, a protective screen be fitted at the pump's suction inlet.

Forces and moments caused by piping connections to the pump should be held to a minimum. Ideally, there should be no forces or moments exerted on the pump casing, which can be achieved by completely supporting the piping.

d. Electrical connections

Standard induction motors are suitable for driving liquid-ring pumps. Starting loads are low so across-the-line operation is normally employed.

It is recommended that a motor controller with over-current protection be used. The full-load current rating, stamped on the motor nameplate, should be used in making the selection for protection rating. A disconnect switch should also be installed between the motor controller and the power supply.

After the electrical work is completed, the pump should be turned by hand. It may be necessary to slacken the gland rings in order for the shaft to turn freely. The direction of rotation is marked by an arrow on the pump. Prime the system, turn on the seal liquid, bump the motor (turn it on and off) to check the pump's rotation, and turn off the seal liquid. If the direction is wrong, reverse any two of the three motor leads and recheck.

e. Accessories

Liquid-ring pumps come with many accessories, supplied by the manufacturer or by other companies in the field. An application's particular requirements, mode of operation, and type of control scheme dictate the necessity of various items. The operation of these items must be reviewed in the manufacturer's manual.

## 4.0 Operation and Maintenance

a. Main Condenser Exhaust Vacuum Equipment

On pump failure, the vacuum pump should automatically isolate itself from the system. This can be done with a check valve or fail closed automated valve tied to the motor starters.

A spare pump may be desired, so that it can be started when condenser vacuum falls below a certain point. This will allow the system to stay on line if there is a vacuum pump failure or excessive leakage. The vacuum level selected should be designed to prevent the turbine from tripping.

b. Water Box and Circulated Water Pump Priming Equipment

A priming valve or stack will be required at high points in the primed system to allow the gas to be pulled off of the system without excessive water being carried over into the vacuum system. A valve for priming service should isolate the primed system from the vacuum system when the water level in the primed system reaches a certain point.

Priming valve materials and parts of the vacuum system which may be in contact with any carryover should be designed to be compatible with the water primed. Because vacuum pump materials may be limited, the use of a drop out receiver tank ahead of the vacuum pumps can help to protect the vacuum pumps from corrosive water spray.

Because the flow of non-condensibles for continuously primed systems is relatively small, it may be suggested to have the vacuum pumps run intermittently to evacuate a vacuum control tank. The pump(s) can be started when the vacuum level drops below a certain point and stopped again once a certain vacuum level is achieved. The added volume of a control tank helps to prevent cycling of pump.

c. Shellside Evacuation Equipment

Typically the Main Condenser Vacuum Pumps serve as the hogging pump as well, therefore the same procedures would be employed.

d. Geothermal

Pumps in Geothermal service are always Stainless Steel material. The installation requirements would be as described above. Care should be taken to observe manufacturer requirements listed in the Installation Manual.

## 5.0 Troubleshooting

Like the proper installation of vacuum pumps, troubleshooting them is critical to their continued operation and maintenance. As a result, it is important that only qualified personnel, using proper equipment, be authorized to perform testing.

There are many factors that can influence the performance of a vacuum system. First, it is always good practice to inspect the equipment when it arrives at site, and then to make sure that the equipment is properly installed, and that all valves and flow switches are in correct direction as per the installation drawings. Verify that the pump rotates freely and in the proper direction, and that the system is properly primed before start-up. All these preliminary checks make troubleshooting of the system easier.

a. Malfunction of the vacuum system could be due to utility or process conditions or the equipment and it is important to determine the cause. A malfunction due to external influences can be determined as follows:

i. The first step is to compare the original design conditions, especially gas composition/flow and cooling liquid temperature to the existing condition.

Any change in the design conditions or the gas's composition may have an effect on the vacuum system. For example, an increase in the condensible load will raise the effective service liquid temperature and effect the vacuum system. High service liquid temperatures will also effect the vacuum level.

ii. Make sure that there is no excessive air in-leakage. Air leakage can be determined by a drop test per HEI *Standards for Steam Jet Vacuum Systems*.

iii. Back pressure on the system should be as per design conditions. Excessive back pressure increases the brake horsepower, and may have an effect on the capacity of the vacuum pump.

b. If it is determined that the malfunction is not due to external influences, troubleshooting of the equipment can be made as follows:

i. Check the service liquid temperature rise across the pump. This should be as per design. Even if cooling liquid temperature and gas composition meet design standards, a reduced flow could be due to a plugged strainer or partially closed valve in the recirculation line. Also, check the recirculating pump's performance (if furnished) and the recirculating heat exchanger for any fouling. Any of these factors could have an effect on the performance of the vacuum system.

ii. Check pump speed with a tachometer to make sure it meets design specification.

- iii. Test the vacuum pump per the HEI *Performance Standards for Liquid Ring Vacuum Pumps*, and compare with the manufacturer's performance curve. Internal clearances may have to be readjusted to meet the performance curve.
- c. A regular maintenance program is important even if the desired vacuum is achieved. The following items should be checked:
  - i. If the vacuum pump is furnished with packing, it is supposed to drip. However, excessive leakage of packing is due to improper adjustment. The packing should be re-adjusted, and the dripping checked to provide proper cooling. Pumps furnished with mechanical seals should not leak. Make sure that the seals are flushed with clean liquid that is compatible with material used.
  - ii. Check for excessive bearing temperatures. The normal temperature is around 140°F. Higher temperatures could be due to misaligned couplings, excessive piping stress, over greasing, worn bearings or contaminated lubricant.
  - iii. Check for excessive noise and vibration of the vacuum pump. This could be caused by coupling misalignment, high service liquid flow, high discharge pressure, an improperly anchored pump, bearing failure, liquid filled casing during startup, or a lack of air flow to the vacuum pump.
  - iv. Check the motor's amperage. A high amperage could be due to high discharge pressure, excessive service liquid flow, or motor malfunction.

## C. Hybrids

### 1.0 Principle of Operation

In the hybrid, a steam jet or air ejector can be used as the first stage of the unit. The ejector discharges into an intercondenser which is followed by a one or two stage liquid ring vacuum pump.

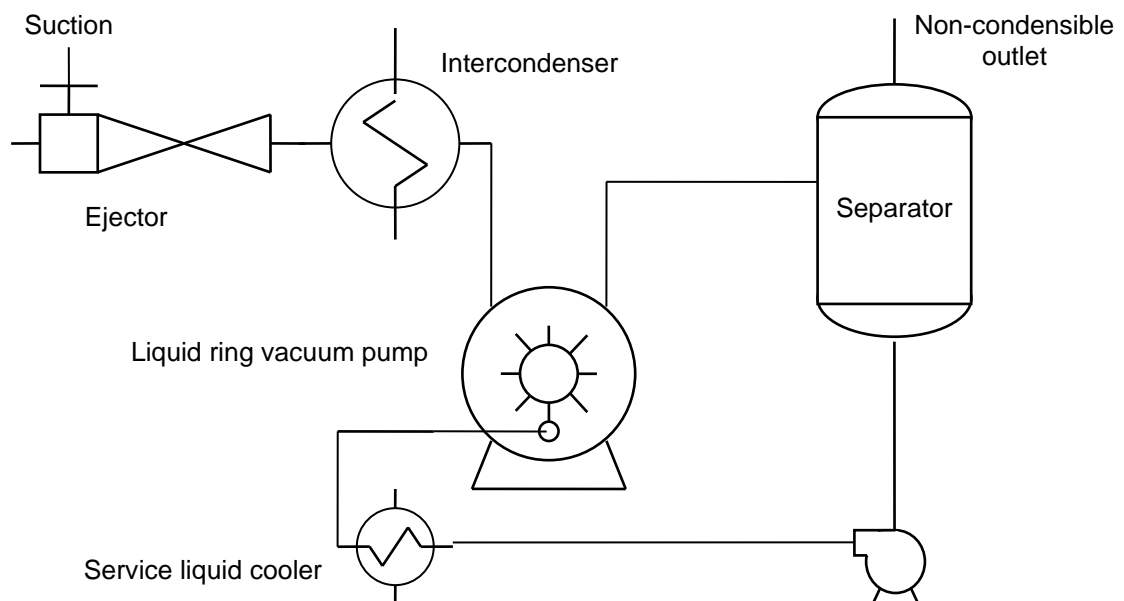

The first stage ejector boosts the interstage pressure to the vacuum pump, thus a smaller pump is required than if the entire compression was to be done by a vacuum pump.

Condensate from the intercondenser can be discharged directly into the liquid ring vacuum pump. Thus no barometric leg or special pumping device is needed for condensate discharge.

Cavitation can be a maintenance problem for stand alone liquid ring vacuum pump systems, which must operate at pressures close to the vapor pressure of the pump service liquid. This problem is minimized when a hybrid system is used, as the vacuum pump operates at a higher interstage pressure. Note that cavitation may still occur if air leakage is near zero.

The first stage ejector boosts the pressure, and the intercondenser condenses the majority of the motive steam and water vapor load, greatly reducing the load to the vacuum pump. Thus a smaller vacuum pump can be used. Hybrid units may be more energy efficient, and can be optimized to account for low cost steam or electric utilities, and can be optimized to achieve the best balance between steam and power usage..

Air motivated ejectors may be utilized, in which case, the intercondenser is not necessary, but will require a larger vacuum pump.

Cooling is by condensate and/or closed cycle cooling water. No raw water is required for the hybrid system.

## 2.0 Design Parameters

Capacity and design suction pressure is determined by the HEI *Standards for Steam Surface Condensers* Table 9 and the HEI *Standards for Air Cooled Condensers* Table 5.. These standards provide recommended venting capacity based on steam flow to the main condenser, as well as number of turbine exhaust openings. Design suction pressure per the HEI standard is 1.0 in.HgA or the condenser operating pressure, whichever is lower, for electric generating units. For mechanical drive units the design pressure is 1.0 inch below the condenser design pressure. This design is the same for a hybrid, all ejector, or liquid ring vacuum pump system.

The cooling water design temperature for a hybrid is normally the closed cycle cooling water temperature or condensate temperature when the main condenser is at its design operating point. Operating characteristics dictated by site specific conditions may require alternate design criteria.

Motive steam design pressure and temperature are site specific. The design steam pressure must be the minimum value that can be provided at the hybrid package.

## 3.0 Installation - New / Retrofit

The operating advantages of the hybrid can be achieved by retrofitting existing ejector or liquid ring vacuum pump systems.

In existing ejector systems, the second stage ejector and aftercondenser can be replaced by a liquid ring pump. This results in the more efficient hybrid arrangement.

Existing liquid ring vacuum pumps can be combined with a new first stage ejector and intercondenser to provide added capacity if the present system is not adequate. This can be due to increased air leakage, decreased pump performance, or operation of the main condenser at off-design conditions. The retrofit will also allow the system to achieve greater vacuum levels, with an improved ability to maintain optimum condenser performance as well as reduce oxygen levels in the condensate.

System design should include all possible countermeasures to prevent the leakage of live steam into the vacuum pump. The pump will be damaged if live steam enters the unit without cooling water supply to the intercondenser and/or no seal water supply during vacuum pump shutdown.

Under no circumstances should steam flow be permitted to enter the pump during vacuum pump shutdown. The following should be considered in the system design:

- A positive sealing valve should be used to isolate live steam from the pump during any time that cooling water to the system is shut off.
- If possible, the interlock system should be designed so that cooling water is continuously supplied to the intercondenser/pump when steam is on.

#### 4.0 Operation & Maintenance

Operation and maintenance of the hybrid system is basically a combination of the above sections covering ejectors and liquid ring pump systems. The hybrid reduces two areas of concern: First, the liquid ring vacuum pump is less susceptible to cavitation damage, as it operates at the relatively high interstage pressure. Setup and monitoring of the vacuum relief device that prevents cavitation is greatly reduced with the hybrid. Second, maintenance of a barometric condensate leg for the intercondenser is eliminated, as the condensate is handled directly into the liquid ring vacuum pump.

#### 5.0 Troubleshooting Tips

Again, troubleshooting hybrid systems is a matter of following the previous discussions listed above in the individual ejector and vacuum pump sections. As with all multi-stage systems, the atmospheric stage equipment should be checked for performance problems first.

### III. Summary/Conclusion

Vacuum systems have been used to service main condensers in power plant applications for over 100 years. Their proper operation is essential to the operation of the entire plant. It is therefore very important for plant personnel to have a good working knowledge of the theory and operating principals of this equipment.

The HEI has developed sizing criteria for vacuum equipment used to service main condensers, which has been used as an industry standard throughout the world since 1933. Useful information can be found in the *Standards for Steam Surface Condensers*, *Standards for Air Cooled Condensers*, *Standards for Steam Jet Vacuum Systems*, and *Performance Standard for Liquid Ring Vacuum Pumps*.

Vacuum equipment is used for numerous applications in the power industry. It serves the steam side and the cooling water side of main condensers in almost all types of power plants. Regardless of the application or the type of plant, the theory and principals of operation are the same for the basic equipment (ejectors, liquid ring vacuum pumps and hybrids). Therefore a review of Section II of this article with respect to the type of equipment encountered by plant personnel, will provide information useful in all applications.