



**OLYMPIC STEEL**

An Integral Piece of Your Metals Supply Chain

# Forward-Looking Statements

Statements contained in this presentation that are not historical facts are forward-looking statements, which involve risks and uncertainties that could cause actual results to differ materially from those expressed in the forward-looking statements. Such forward-looking statements are made pursuant to the safe harbor provisions of the Private Securities Litigation Reform Act of 1995. Please refer to the Company's Securities and Exchange Commission filings for further information, including its most recent reports on Form 10-K and its quarterly reports on Form 10-Q.

# North American Metals Service Center

What you need. Where you need us. Since 1954.

- Carbon and Coated Sheet, Plate and Coil
- Stainless Steel Sheet, Plate, Bar and Coil
- Aluminum Sheet, Plate and Coil
- Pipe, Tube, Valves and Fittings
- Tin Plate

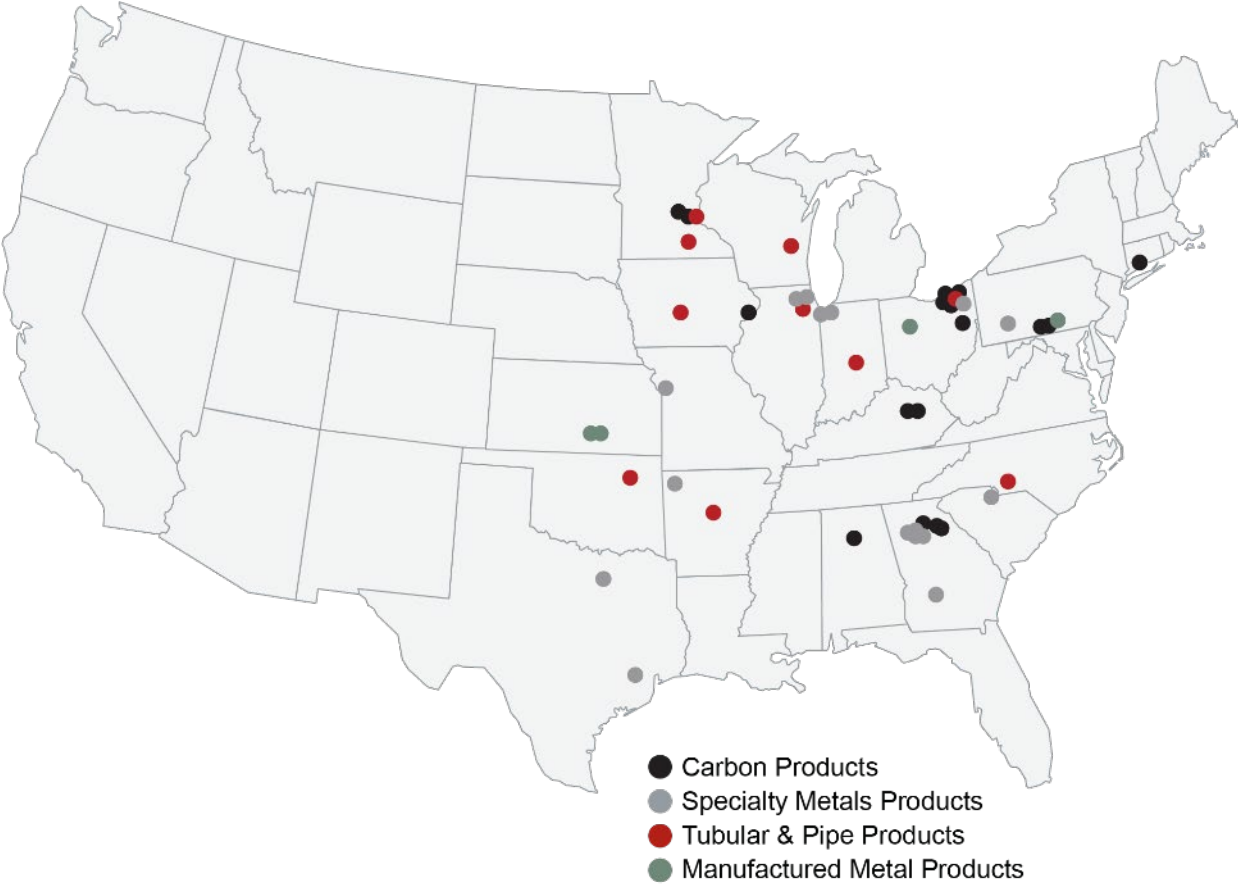

# A Leading North American Metals Service Center

We respond directly to customer needs and emphasize **value-added processing** of metals to meet specific customer demands.

Utilizing specialized equipment, our processes produce metals to specified lengths, widths, shapes and surface characteristics.

Headquartered in Highland Hills, OH.

Trades on NASDAQ under the symbol: ZEUS.

**1954**  
Founded

**47**  
Facilities

**~2,100**  
Employees

**\$2.2B**  
2023 Revenue

## Three Complementary Segments

### Specialty Metals Flat Products

Direct sale and distribution of processed aluminum and stainless flat-rolled sheet and coil products, flat-bar products and fabricated parts

### Tubular & Pipe Products (Chicago Tube & Iron)

Distribution of metal tubing, pipe, bar, valve and fittings and fabrication of pressure parts supplied to various industrial markets

### Carbon Flat Products

Direct sale and distribution of large volumes of processed carbon and coated flat-rolled sheet, coil and plate products and fabricated parts

# Three Complementary Segments

Diverse product offering, distinct value-added processing capabilities

## Specialty Metals Flat Products

- Stainless steel and aluminum
- Fastest-growing segment, serving growth markets
- Higher returns vs. carbon service centers
- Recent expansion of processing capabilities and M&A



## Tube, Pipe & Bar Products

- Less cyclical and higher returns due to niche markets
- Highly engineered value-added processing

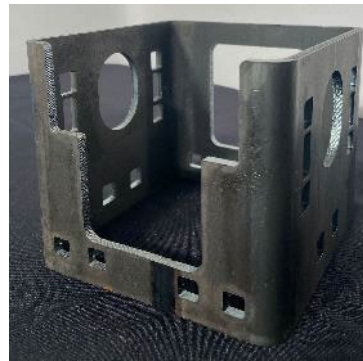

## Carbon & Coated Flat Products

- High-volume business
- Margin enhancement through value-added processing and acquisition of metal-intensive branded products
- Focus on higher margin products and fabrication

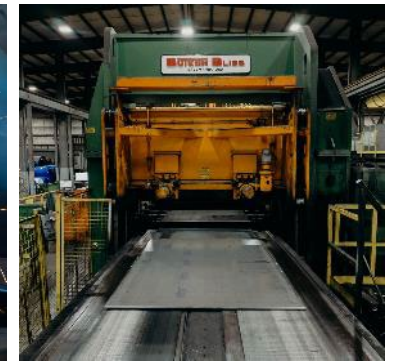

# Value-Added Processing

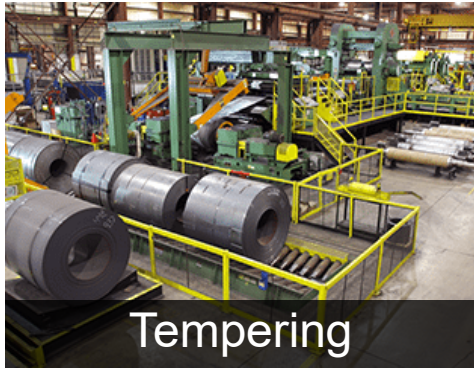

# Exceeding Customer's Unique Requirements

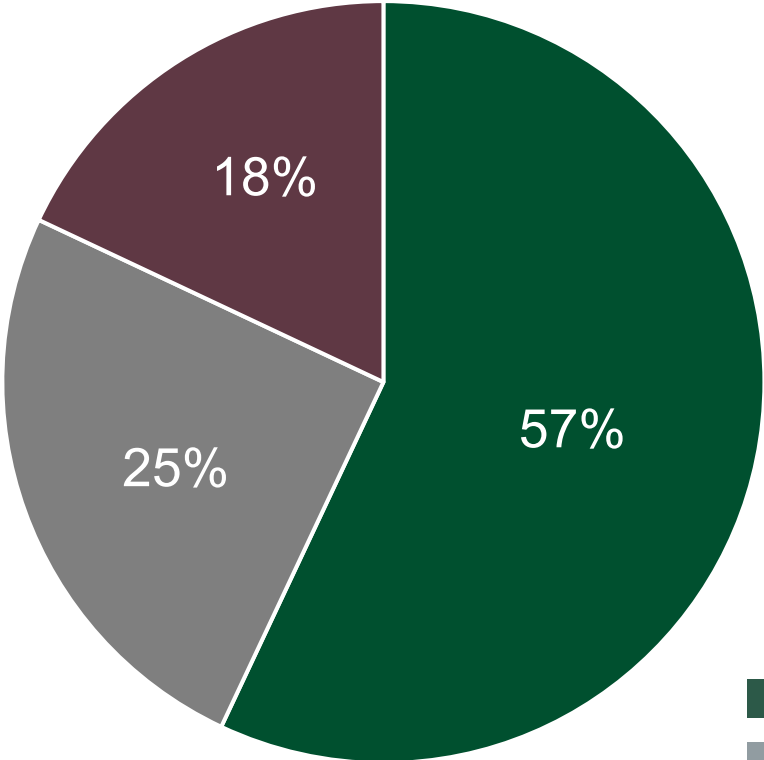

- Carbon Flat Products
- Specialty Metals
- Tubular & Pipe Products



# Unique Customer Programs

**Quick Pay Programs**

**Stock & Hold Inventory Programs**

**Consignment Inventory Programs**

**Quality & Technical Service**

**Just-In-Time Delivery**

**Buying Power & Strategic Sourcing**

**Hedging**

**Flexible Delivery Program**



# Product Processing

## Sheet & Plate Processing      Tube & Pipe Processing

	Bevel Head Burning	Centerless Grinding	CNC Machining	Cutting to Length	Deburring	Edge Conditioning	Faro Arm Inspection	Forming - Brake Press	Forming - Plate Rolling	General Inspection	Laser Burning	Mechanical Testing Lab	Oxy Fuel Burning	Painting	Plasma Burning	Polishing	Shearing	Shot Blasting	Slitting	Stamping/Blanking	Stretch Leveling	Tempering	Virtek Inspection	Waterjet Cutting	Welding/Laser Welding	Beveling	Coiling	Cut Grooving	Features Post Bend	Flaring	Heat Treating	Hot & Cold Bending	Hydro Testing	Laser Testing	Lathe Fabrication	Mitre Cutting	Roll Grooving	Rotary Draw Bending	Saw Cutting	Swaging	Threading	Xray								
<b>Olympic Steel</b>							X	X	X												X	X																												
- Bartlett, IL							X	X	X								X				X	X																												
- Bettendorf, IA	X	X	X	X	X	X	X	X	X	X	X	X	X	X			X				X	X		X	X																									
- Buford, GA	X	X	X	X	X	X	X	X	X	X	X	X	X	X			X							X	X																									
- Chambersburg, PA	X	X	X	X	X	X	X	X		X	X	X	X	X			X							X	X																									
- Cleveland, OH			X			X		X	X	X	X	X	X	X									X																											
- Dover, OH				X				X			X	X	X	X			X																																	
- Gary, IN								X	X												X																													
- Milford, CT			X				X			X								X		X			X																											
- Minneapolis, MN	X	X	X	X	X	X	X	X	X	X	X	X	X	X			X	X	X	X	X		X																											
- Mt Sterling, KY	X	X	X	X	X	X	X	X	X	X	X	X	X	X			X																																	
- Schaumburg, IL			X					X								X																																		
- Winder, GA			X					X	X									X	X	X																														
<b>Action Stainless &amp; Alloys</b>	X	X							X				X											X																										
<b>Berlin Metals</b>			X															X																																
<b>Central Tube &amp; Bar</b>		X	X		X	X		X			X													X	X			X	X	X	X	X	X	X	X	X	X													
<b>Chicago Tube &amp; Iron</b>		X	X								X													X	X	X	X	X	X	X	X	X	X	X	X	X	X	X	X	X	X	X	X	X	X	X				
<b>EZ-Dumper</b>																								X																										
<b>Integrity Stainless</b>			X	X									X	X		X	X	X																																
<b>McCullough Industries</b>						X		X			X	X	X		X		X							X																		X								
<b>Metal-Fab</b>			X	X		X		X		X		X		X		X		X	X					X					X													X	X							
<b>Shaw Stainless &amp; Alloy</b>		X	X			X		X		X		X	X		X	X							X	X														X				X	X							



# Doing Business the Right Way

## Our culture drives results

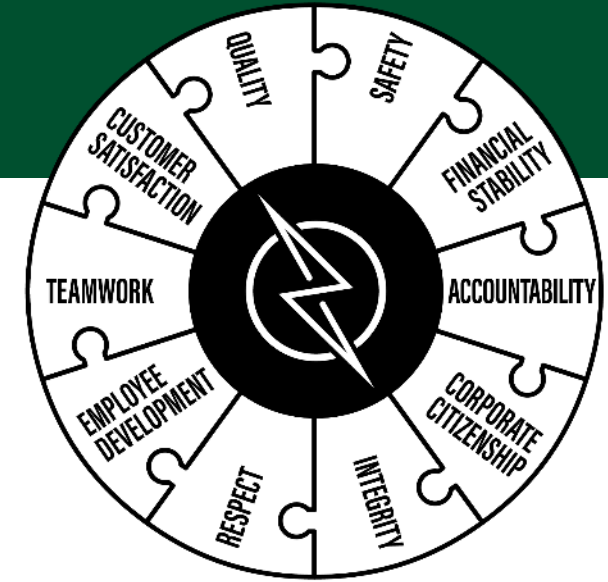
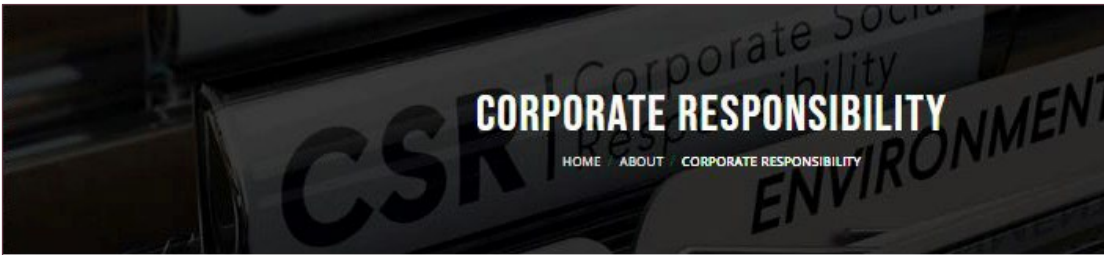

View our Corporate Responsibility Report on [olysteel.com](http://olysteel.com)

**Safety first. Always.**

### INVESTOR RELATIONS

- CORPORATE PROFILE
- CORPORATE RESPONSIBILITY
- NEWS RELEASES
- PRESENTATIONS
- ANALYST COVERAGE
- ANNUAL REPORTS
- PROXY STATEMENTS
- MANAGEMENT PROFILE
- DIRECTORS
- BUSINESS ETHICS POLICY
- CORPORATE GOVERNANCE GUIDELINES



### OUR COMMITMENT TO OPERATING RESPONSIBLY



At Olympic Steel, our mission is to achieve profitable growth by safely providing quality business solutions for metal product users. Since opening in 1954, we have been committed to operating responsibly and in compliance with all federal, state and local requirements in all facets of our business. This commitment is reflected in our **Core Values** and the ways in which we support our customers and the communities where we operate.

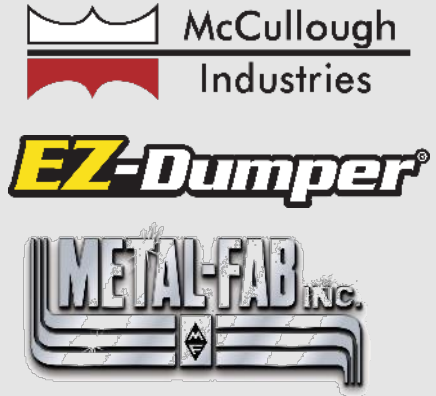

# Investing in Growth to Support Our Customers

	Specialty Metals (Stainless & Aluminum) Products Segment	Pipe, Tube & Bar Products Segment	Carbon & Coated Flat Products Segment
M&A			
Organic Growth	<ul style="list-style-type: none"> <li>Expanded Schaumburg, IL facility by 42,000 sq. ft. and added white metals cut-to-length line</li> <li>Added second stainless steel slitter in Streetsboro, OH facility</li> <li>Added 80,000 sq. ft. fabrication facility in Bartlett, IL</li> <li>Installing fully-automated packaging line in Streetsboro, OH - <i>to be completed in early 2024</i></li> </ul>	<ul style="list-style-type: none"> <li>Installed new, state-of-the-art tube laser equipment in CTI Romeoville, IL</li> <li>Increased from over 37% valued-added processing with the goal of moving to 50%</li> <li>CTI expanded distribution and fabrication in Southeast U.S.</li> </ul>	<ul style="list-style-type: none"> <li>Opened Buford, GA fabrication facility</li> <li>Added (2) automotive stamping lines in Winder, GA</li> <li>Enhanced robotic welding capabilities in Buford, GA and Mt. Sterling, KY</li> <li>Added new high efficiency lasers in Buford, GA</li> <li>Divested of Detroit, MI facility</li> </ul>

# Supplying Metals Markets Since 1954

## 1Q 2024 Net Sales by End Market

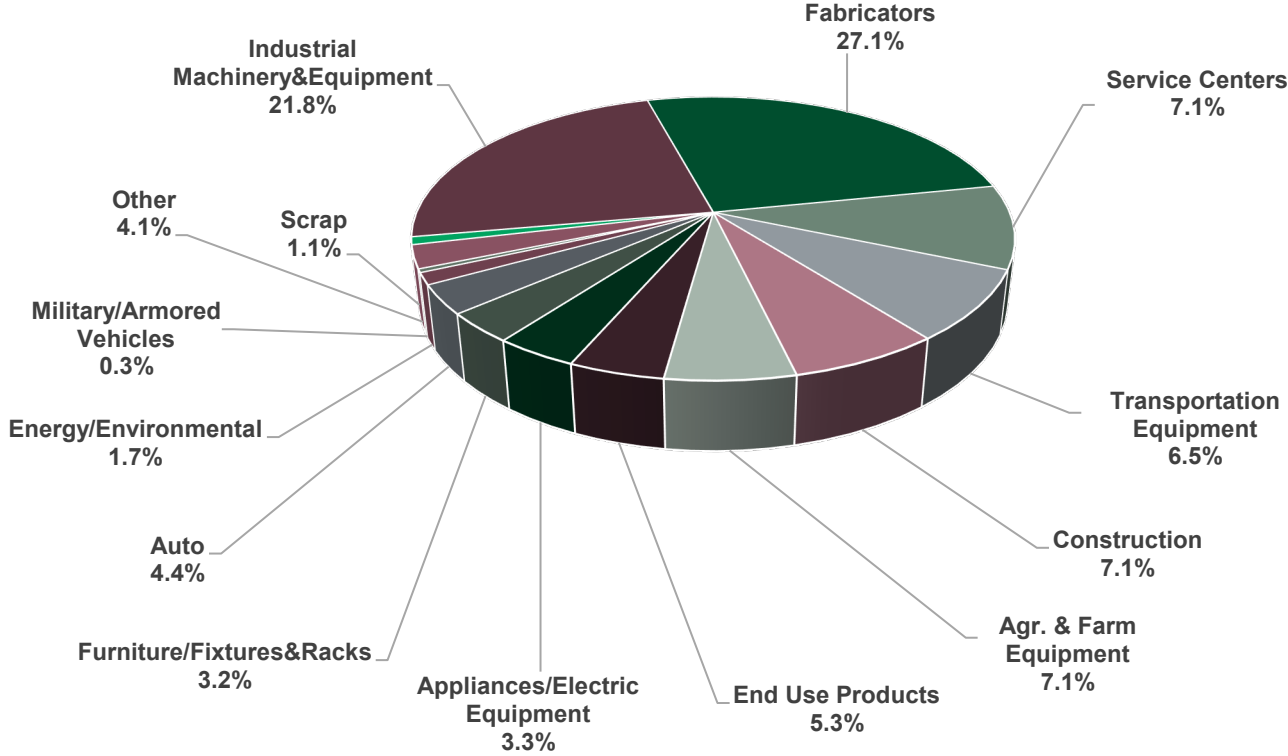

# SE Region

300,000 square feet

Stretcher Leveling

Cutting to Length

Slitting

Stamping

Laser & Plasma Cutting

Forming & Roll Forming

Machining & Shot Blasting

Projection Welding

Welding

Flattening

Hot Rolled Carbon Coil,  
Sheet & Plate

Hot Rolled P&O Coil  
& Sheet

Cold Rolled Carbon Coil  
& Sheet

Coated Coil & Sheet

Stainless Steel Coil  
& Sheet

Aluminum Coil & Sheet



# Winder, GA

285,000 square feet

Stretcher Leveling

Cutting-to-Length

Slitting

Stamping

Hot Rolled Carbon Coil,  
Sheet & Plate

Hot Rolled P&O Coil  
& Sheet

Cold Rolled Carbon Coil  
& Sheet

Coated Coil & Sheet

Stainless Steel Coil  
& Sheet

Aluminum Coil & Sheet

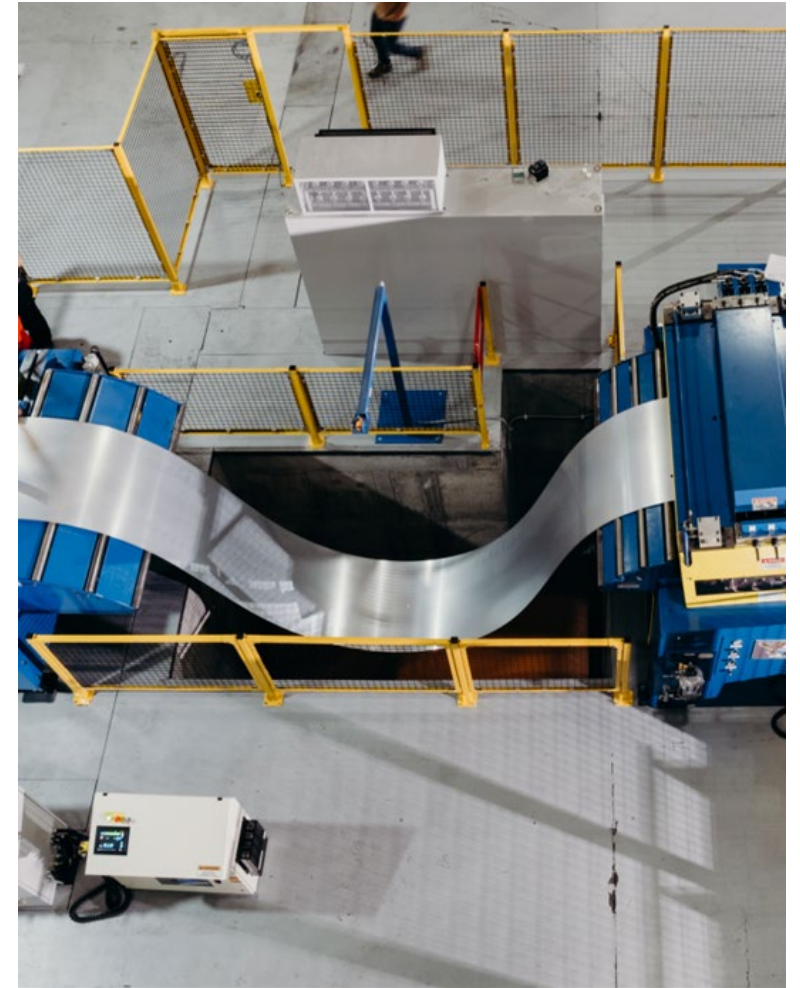

# Buford, GA

120,000 square feet

Laser Cutting

Plasma Cutting

Forming

Roll Forming

Machining

Blasting

Projection Welding

Welding

Flattening

Hot Rolled Carbon Coil,  
Sheet & Plate

Hot Rolled P&O Coil  
& Sheet

Cold Rolled Carbon Coil  
& Sheet

Coated Coil & Sheet

Stainless Steel Coil  
& Sheet

Aluminum Coil & Sheet

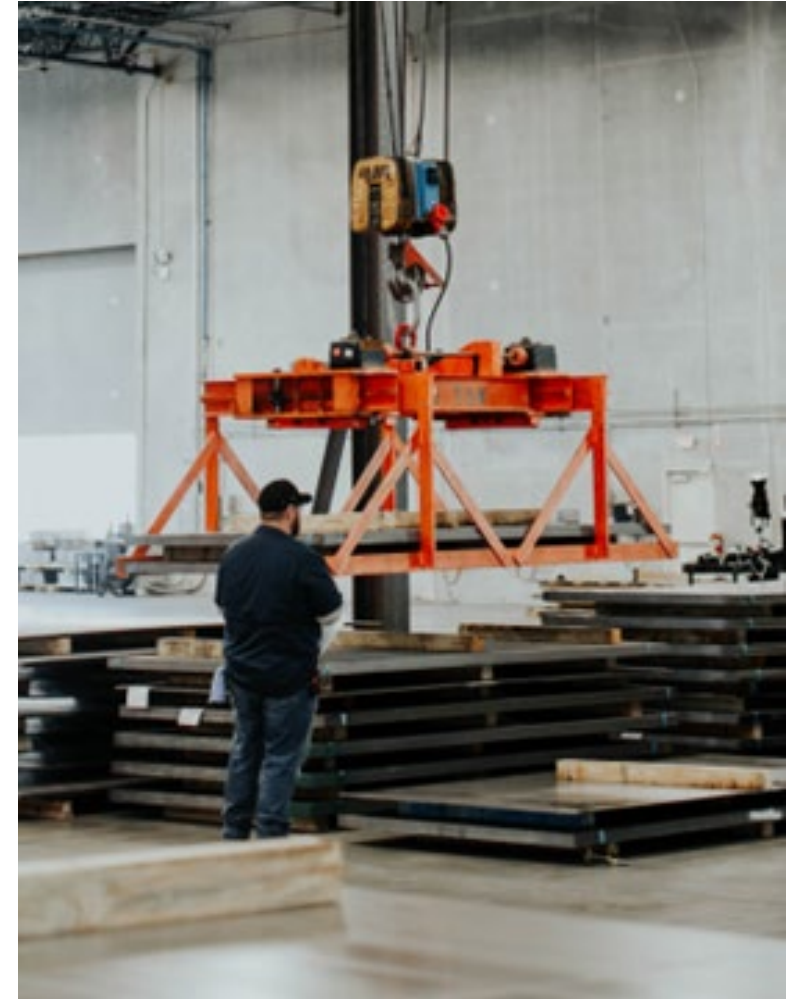



Founded in 1979

120,000 square feet

Facilities in Marietta,  
Hiram, Powder Springs  
and Albany, Georgia

3275 Florence Road  
Bldg. 100  
Powder Springs, GA 30127  
800.724.1521  
[stainlessandalloy.com](http://stainlessandalloy.com)

## FULL-LINE DISTRIBUTOR

Stainless Steel Sheet

Pipe

Tube

Bar

Angles

## MANUFACTURER & DISTRIBUTOR

Stainless Steel  
Bollards

Water Treatment  
Systems







Your One Stop Shop For All of Your  
Fabrication and Distribution Needs



# Stocking Distributor of Stainless-Steel Pipe Valves, Fittings, Flanges, Flat and Round Bar, and Structural Materials

Fully Stocked Warehouses Serving the Southeast





- 4 KW Fiber Laser 72 x 144
- Shuttle Table



### **AMADA (14' Bed High Precision Press Brake**

- FULL AUTO
- 20" CAPABLE
- MITER CUT



### **4 Roll Plate Rolling Machine**



### **Cobot Robotic Welding**



### **Pipe Fabrication**



MIG and TIG welders  
for both General  
Fabrication as well as  
our new Pipe  
Fabrication facility.



outfitting our facilities for both  
CNC Mills and Lathes.



**Laser Welding**

We have been greatly fortunate to have  
added several fantastic new faces with over  
40 combined years of experience in this field.

# Complex System Capabilities



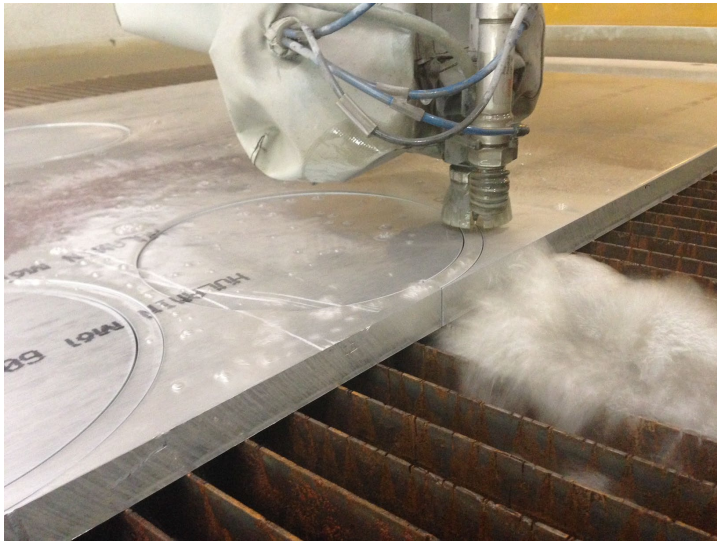
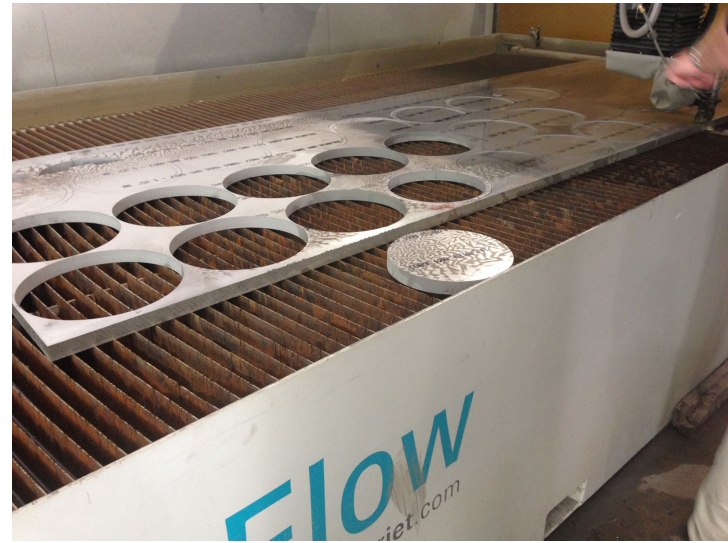

All In-House  
Fabrication  
Capabilities





## Barriers<sup>1</sup> and Stainless Covers

<sup>1</sup>Crash Rated and Non-  
Rated



# Barrier / Bollard Division

Freedom Tower / World Trade Center





# Bollard / Barrier Division

## Sports Complexes



# **Bollard Division**

Office Buildings – Comcast Headquarters

# Active Barriers

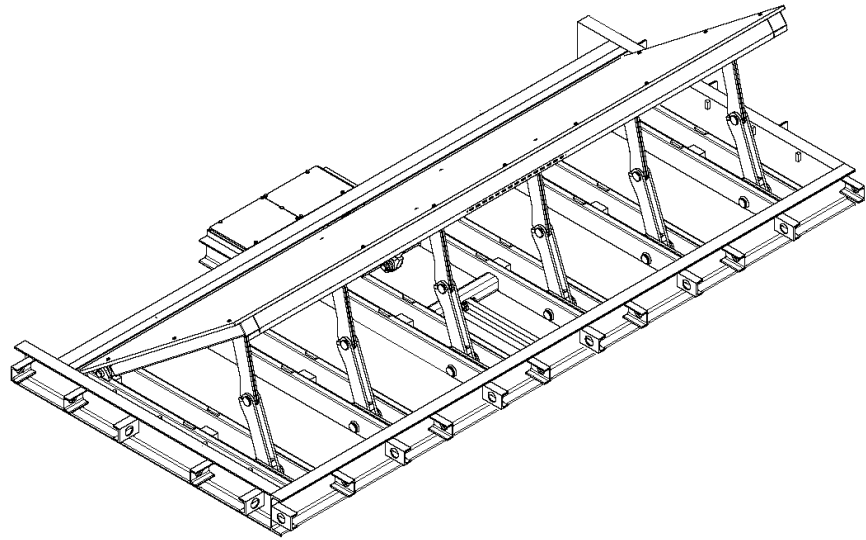





**McCullough  
Industries**

75,000 square feet

Industrial Storage and  
Material Handling  
Products

More Than 1,000  
Product Variations  
Available

Made in America  
Since 1965

13047 County Road 175  
Kenton, Ohio 43326  
800.245.9490  
[mcculloughind.com](http://mcculloughind.com)

## The Wright® One!

Quick Attach Hoppers

Self-Dumping Hoppers

Low Profile  
Dumping Hoppers

Bump-Release Hoppers

Heavy Steel Construction

Stainless Steel Available

1/4 Yard – 5 Yard  
Hoppers



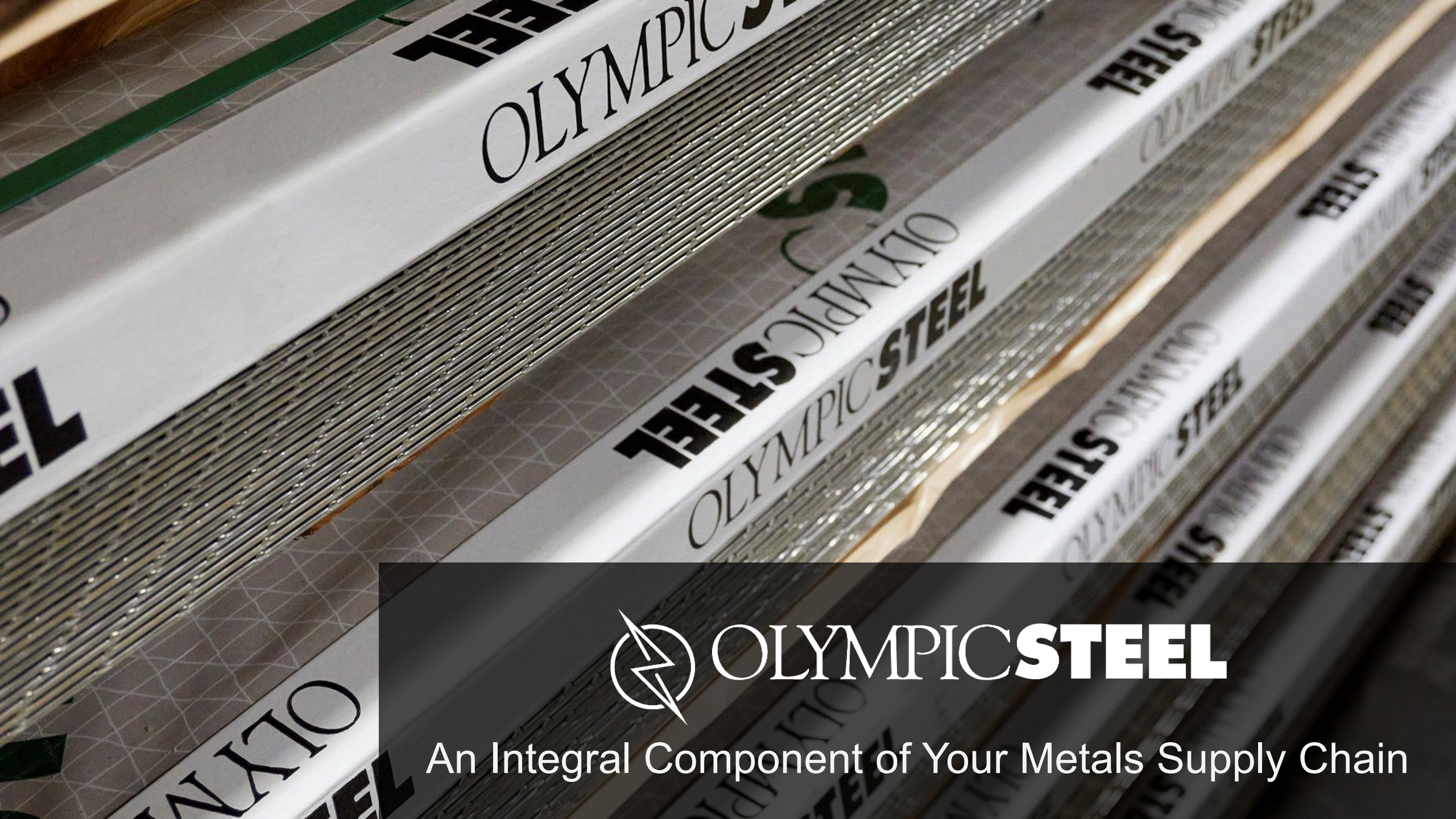

**OLYMPICSTEEL**

An Integral Component of Your Metals Supply Chain

# Appendix

# End-Use & Branded Products



Bollards & Custom Water Tanks



Self-Dumping Hoppers



Air Venting & Filtration



Metal Truck Inserts





# Bartlett, IL - 81,400 sq. ft.

## Equipment

### Burning

- Mitsubishi
- 4020 (8K) Laser w/Tower
  - 4020 (6K) Laser

### Forming

- Cincinnati Brake Presses
- 230 tons x 144" long
  - 90 tons x 120" long
  - 60 tons x 39" long
  - 40 tons x 39" long

### Welding

- MIG Weld Stations (2)
- TIG Weld Station

### Inspection

- Virtek Inspection
- Precision Measuring
- Rapid Scan
- ISO Certified



# Buford, GA – 120,000 sq. ft.

## Equipment

### Burning

- Plasma Bevel / Oxy
- CO<sub>2</sub> Laser 4.5k
- Fiber Lasers (8k – 20k)

### Forming

- 165-ton x 10'
- 350-ton x 12'
- Davi 10' 4 Pinch Roller

### Flattening

- 40-ton Flattener

### Machining

- HAAS VF7
- HAAS VF10

### Welding

- Resistance / Manual / Robotic

### Finishing

- Wheelabrator 5' Parts Blaster



Carbon Sheet & Plate – HR / CR / Coated / Plate ▪ Stainless ▪ Aluminum



# Mt. Sterling, KY - 207,000 sq. ft.

## Equipment

### Burning

- Plasma / Oxy

### Laser

- 10,000 Watt Mitsubishi 4020GX-F100 Fiber
- 2 x 6,000-watt Tanaka Lasers (66')

### Forming

- Cincinnati 600 Ton - 20'
- Pacific 230 ton - 12'
- 750-ton LVD press – 18'

### Machining

- Haas VF6
- Haas VF12

### Welding

- 4 mig weld station
- Lincoln Electric Dual Arm Weld Robot with 13' Dro

### Finishing

- Wheelabrator shotblaster



# Chambersburg, PA – 307,000 sq. ft.

## Equipment

### Burning

- MG MPC 2000 (2)
- MG MPC 2020 (2)
- MG MPC 2012 Multi-Process (2)

### Forming

- 320-ton Accurpress
- 750-ton Accurpress (2)
- 750-ton Cincinnati

### Machining

- PMC 5000 200" x 100"
- Haas VS-3 150" x 50"
- Haas VF-6 64" x 32" (2)
- Haas VF-5 60" x 26"
- Haas VF-7 84" x 30" (2)
- AWEA SP 3016 120" x 63"
- Cincinnati Lancer 120" x 30"
- V-Tech 5230 103" x 198"
- Haas EC 1600 64" x 34"
- V-Tech 5230 103" x 198"
- (2) Puma 12 LC Lathe
- Vertical lathe with 60" table

### Welding

- Robotic Weld Cells (2)
- Miller Deltaweld Stations (8)

### Finishing

- 6 Wheel Shotblasting Machine
- ABS Blast booth
- Mesh Belt Parts Blaster



Carbon Sheet (HRPO) & Plate (HT and Alloy) ▪ Stainless ▪ Aluminum



# Minneapolis, MN - 115,000 sq. ft.

## Equipment

### Burning

- Alltra 12 Torch
- Alltra 2 Torch Hi Def (2)

### Laser

- Mitsubishi 4020RX-45CF-R Lasers (2)

### Machining

- (3) HAAS GR 712 - 72" x 144"
- HAAS VF3YT - 25" x 40"
- HAAS VF5/50 - 26" x 50"
- HAAS VF8/50 - 40" x 64"
- HAAS VF11/50 - 120" x 40"

### Finishing

- Wheelabrator 6 Wheel Horizontal Shotblasting Machine

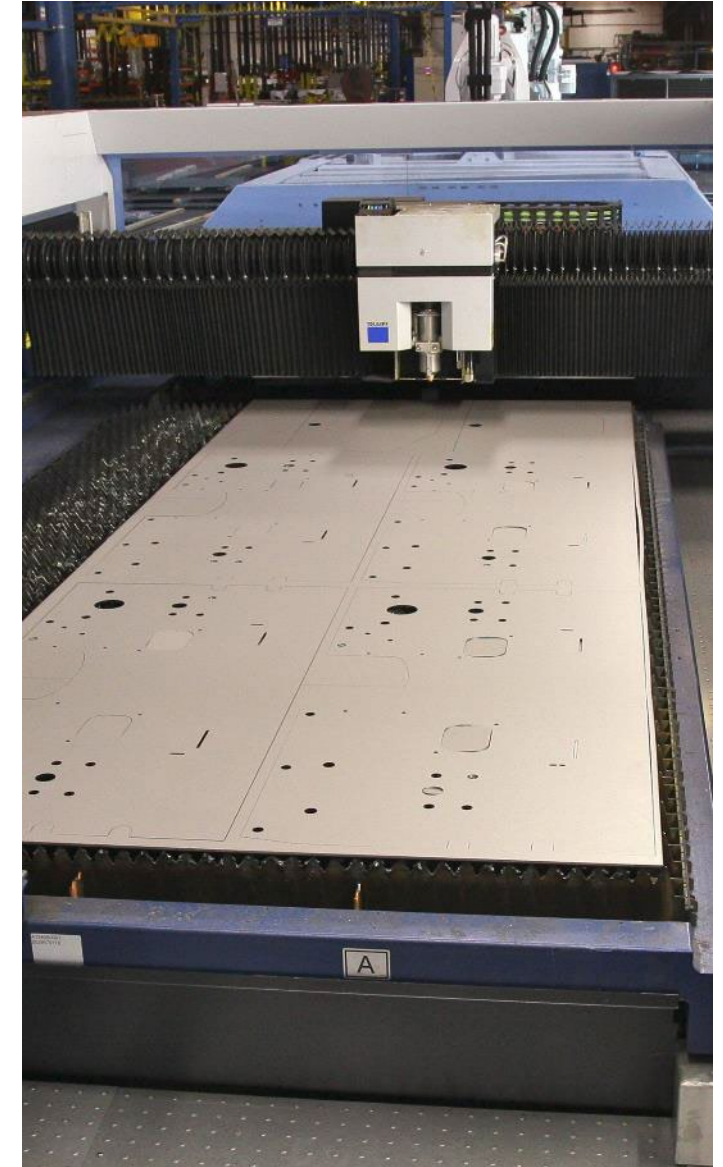
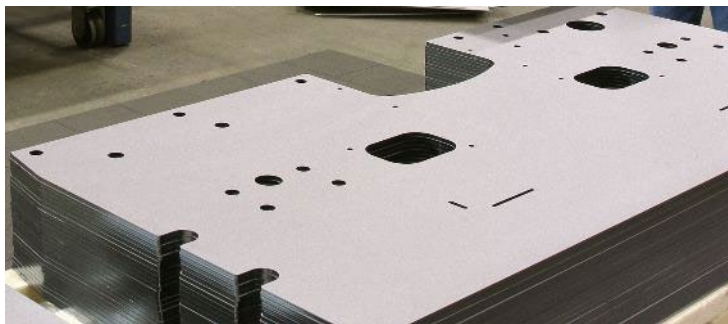

Carbon Sheet & Plate – HRPO / Cold Rolled / Ultra High Strength

# Bettendorf, IA – 244,000 sq. ft.

## Equipment

<b>Temper Mill</b>	<ul style="list-style-type: none"><li>• 14 ga - .5" Thick</li><li>• 32" - 74" Width; 42" - 530" long</li></ul>
<b>Burning</b>	<ul style="list-style-type: none"><li>• Alltra PG-14 10/12 Hydef Plasma</li><li>• Messer MG 4600 Plasma</li><li>• ESAB Avenger 2 Oxyfuel</li></ul>
<b>Laser</b>	<ul style="list-style-type: none"><li>• Trumpf 5060 Laser</li><li>• Mitsubishi Fiber Laser 6030 XL-F</li></ul>
<b>Forming</b>	<ul style="list-style-type: none"><li>• Cincinnati 600 ton - 20'</li><li>• Pacific 230 ton - 12'</li><li>• Cincinnati 1000 ton - 16'</li></ul>
<b>Machining</b>	<ul style="list-style-type: none"><li>• Haas VF4 (2)</li><li>• Haas VF8</li></ul>
<b>Finishing</b>	<ul style="list-style-type: none"><li>• Metcast M-4/96 - horizontal plate shotblasting</li><li>• LS Industries - parts blaster</li></ul>

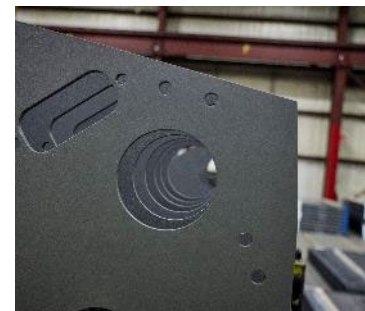
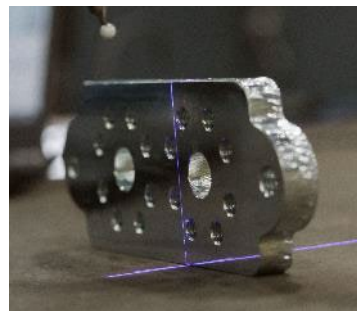
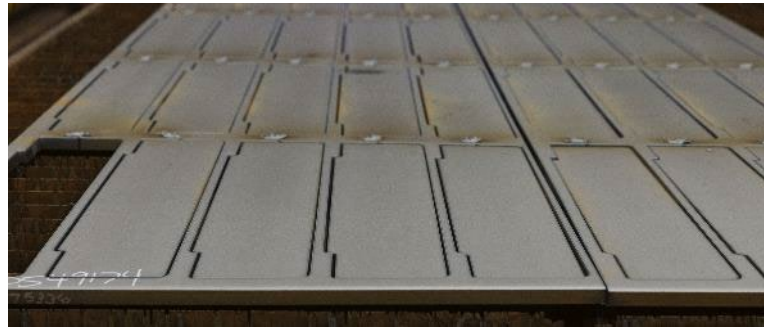

# Cleveland, OH – 310,000 sq. ft.

## Equipment

### Burning

- MG 8 Torch OxyFuel
- Messer Evolution High Performance/Definition Plasma System

### Laser

- Mitsubishi ML 6030 Laser
- Mitsubishi XL-F 6030 Fiber Laser (3)
- Mitsubishi 4020 GX-F80 Fiber Laser

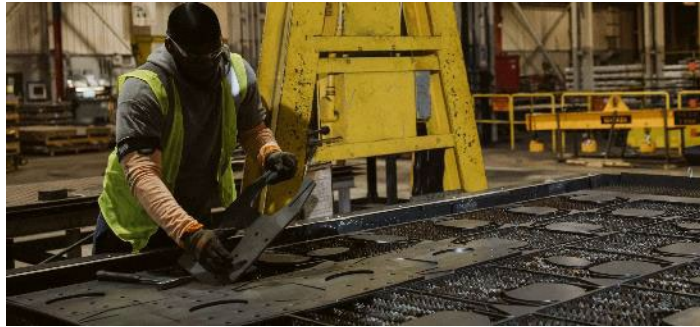

# Action Stainless & Alloys

## Equipment

### Centerless Grinding

1/4" to 9.5" diameter  
6' to 24' lengths  
+/- .001 or tighter

### Cutting

- Laser - up to 1/2"
- Water Jet - up to 5 1/2"
- Plasma (CAD) - up to 2"
- Saw - up to 18"

### Kitting

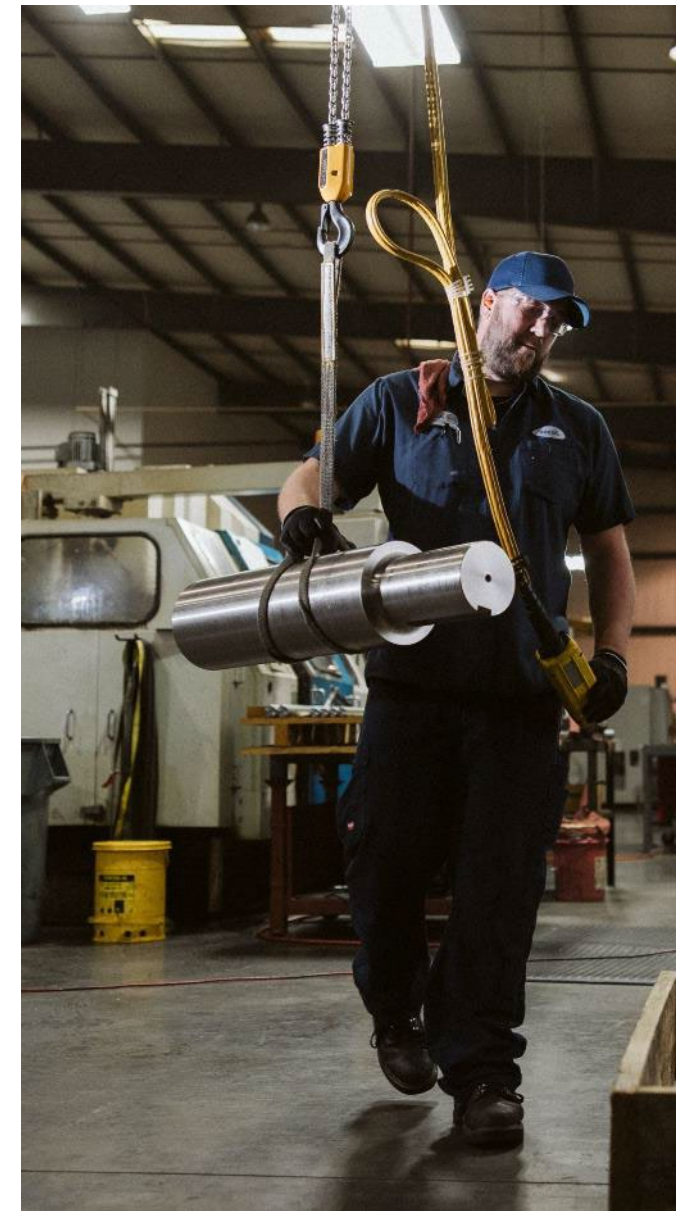
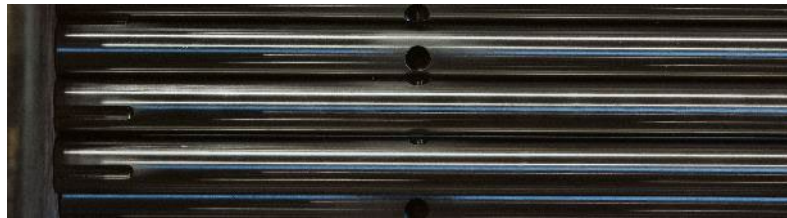



# CTI / CTB – (Multiple Locations)

## Equipment

<b>Burning</b>	<ul style="list-style-type: none"><li>• 10k Fiber Laser</li></ul>
<b>Tube Lasers</b>	<ul style="list-style-type: none"><li>• (18) Up to 40' In/Out, Round to 16", Square to 12"</li></ul>
<b>Tube Bending</b>	<ul style="list-style-type: none"><li>• 6 Axis, Weld Seam Direction, Full Mandrel</li></ul>
<b>Sawing</b>	<ul style="list-style-type: none"><li>• CNC Band Saws - 36"OD x 48' Length</li><li>• Tsune CNC Cold Saws - 4"OD x 20' length</li></ul>
<b>Welding</b>	<ul style="list-style-type: none"><li>• Manual and Robotic</li></ul>
<b>Assembly</b>	<ul style="list-style-type: none"><li>• Complete System Assembly Available</li></ul>

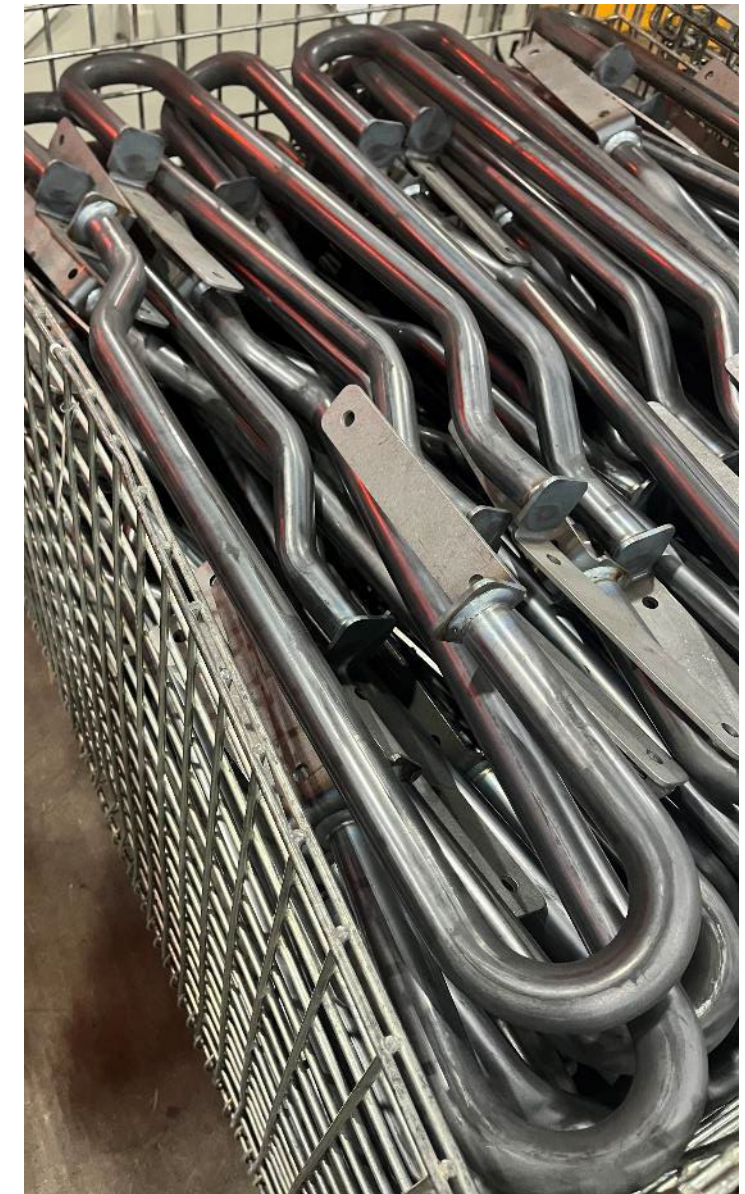

# Shaw Stainless & Alloy - 100,000 sq. ft.

## Equipment

<b>Burning</b>	<ul style="list-style-type: none"><li>• Fiber Laser</li><li>• Plasma</li></ul>
<b>Cutting</b>	<ul style="list-style-type: none"><li>• Band Saws</li><li>• Waterjet</li></ul>
<b>Forming</b>	<ul style="list-style-type: none"><li>• Press Break</li><li>• Plate Rollers</li><li>• Roll Grooving</li></ul>
<b>Welding</b>	<ul style="list-style-type: none"><li>• Manual</li><li>• Robotic</li><li>• MIG</li><li>• TIG</li><li>• Automatic Seam Welding</li></ul>
<b>Finishing</b>	<ul style="list-style-type: none"><li>• Stainless Polishing</li><li>• Electropolishing</li><li>• Passivation</li></ul>
<b>Assembly</b>	<ul style="list-style-type: none"><li>• Turnkey Wastewater Solutions, Security Bollards, Other Assembly</li></ul>





# Action Stainless

Dallas, TX

Houston, TX

Springdale, AR

Rock Hill, SC

Kansas City, MO

1505 Halsey Way

Carrollton, TX 75007

972.466.1500

[actionstainless.com](http://actionstainless.com)

## SERVICES

Plasma Cutting

Laser Cutting

Waterjet Cutting

Saw Cutting

Precision

Bar Grinding

Centerless Grinding

CNC Machining

Fabrication

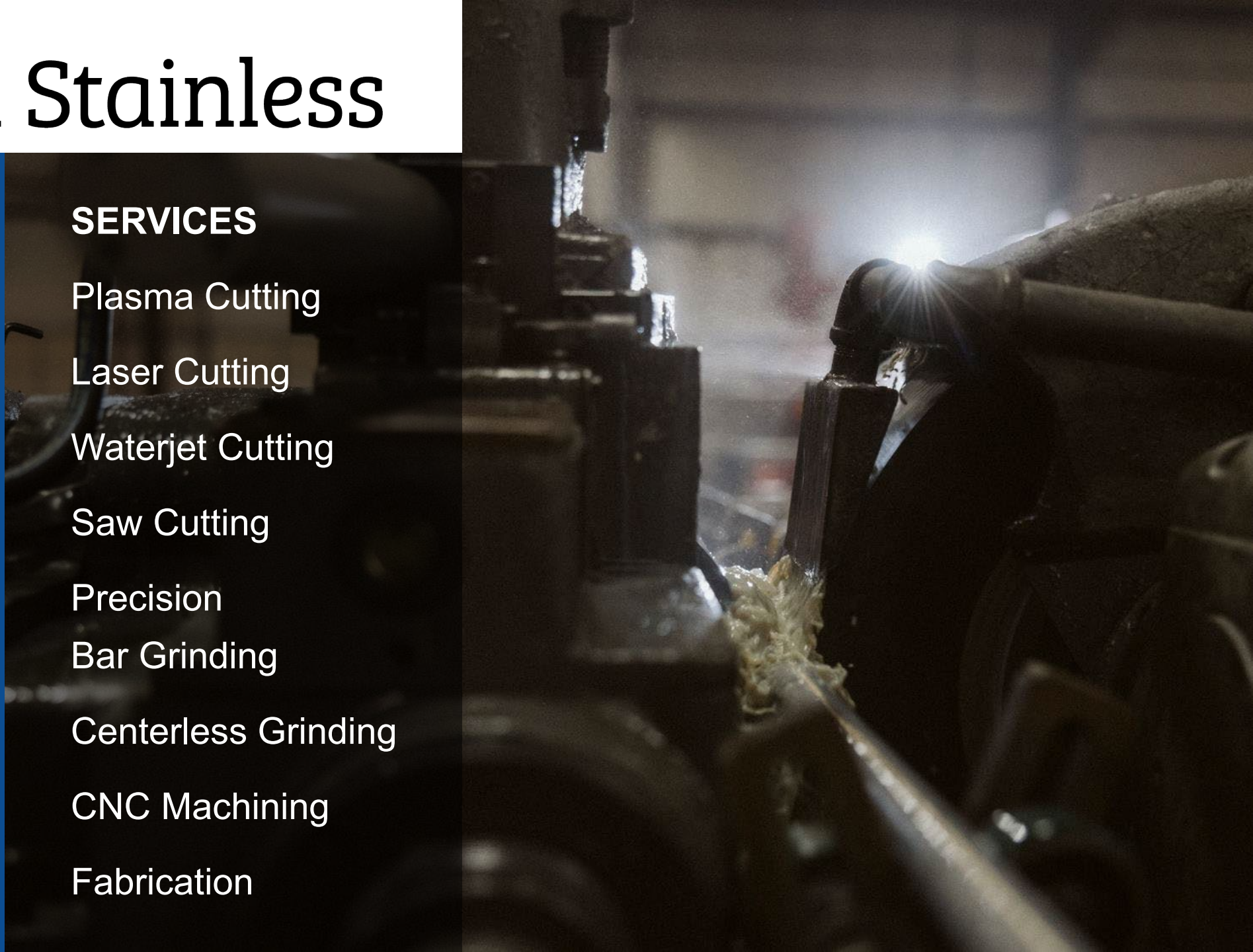



Hammond, IN

140,000 square feet

Precision Coil Slitting

Cutting to Length

3200 Sheffield Avenue

Hammond, IN

800.754.8867

[berlinmetals.com](http://berlinmetals.com)

Black Plate

Coated Steel Coil

Cold Rolled Steel  
& Strip

Galvanized Light  
Gauge Coil

Stainless Steel Strip

TFS Tin Free Steel

Tin Coated Steel

Tin Plate





Founded in 1996

3 Facilities

162,000 square feet

Conway, AR

Tulsa, OK

25 Middle Road

Conway, AR 72032

501.299.9223

[centraltubeandbar.com](http://centraltubeandbar.com)

## PRODUCTS

Carbon & Alloy Tube

Aluminum & Stainless  
Tube

Carbon & Alloy Bar

## SERVICES

Laser Tube Cutting

CNC Bending  
& Tube Bending

Robotic Welding

Sawing

Fab & Assembly

Contract  
Manufacturer





10 Facilities

1.2M square feet

30,000 line items

Precision Parts

Tube Laser Cutting

Bending

Welding

Kitting

Sawing

One Chicago Tube Drive

Romeoville, Illinois 60446

800.754.8867

[chicagotube.com](http://chicagotube.com)

Round Mechanical  
Tube

Square, Rectangular  
& Round Tube

Hydraulic Tube

Cold Finished /  
Hot Roll Bar

Stainless Pipe,  
Tube & Bar

Aluminum Pipe,  
Tube & Bar

Carbon Steel Pipe

Valves & Fittings

Boiler Tube

ASME Pressure Parts



# **EZ-Dumper®**

## **The Original Dump Insert**

Exceptional Quality  
and Customer Service  
Since 1972

1530 Nitterhouse Drive  
Chambersburg, PA 17201  
866.967.DUMP  
ez-dumper.com

### **INSERTS FOR EVERY NEED**

Steel Dump Inserts

Stainless Steel  
Dump Inserts

Custom Service Body  
Dump Inserts

Durable Construction

8' Model Fits Most  
Standard Pickup Trucks

Smaller 6' Model Fits  
Most Short Bed Trucks





110,00 square feet

Precision Slitting

Edging & Oscillating

Precision Blanking

Shearing

3000 Crane Center Drive

Streetsboro, OH 44241

440.287.0150

[integritystainless.com](http://integritystainless.com)

## PRODUCTS

Stainless Steel

Coil

Slit Coil

Flat Bar

Round Bar

## EQUIPMENT

(2) 60" slitters .015 – 3/16"

(1) 24" slitters .010 – 3/16"

(2) Edging &  
Oscillation lines

(5) Polishing &  
Finishing lines







44,000 square feet

Cutting to Length

Precision Blanking

Shearing

Edging

161 Devereux Drive

Latrobe, PA 15650

724.532.1550

[integritystainless.com](http://integritystainless.com)

## PRODUCTS

Stainless Steel

Coil

Slit Coil

Flat Bar

Round Bar

## EQUIPMENT

60" Cut to Length Line  
with paper interleave  
& PVC

(3) Shears

10ga – .25" x 72 wide

(2) Edging lines

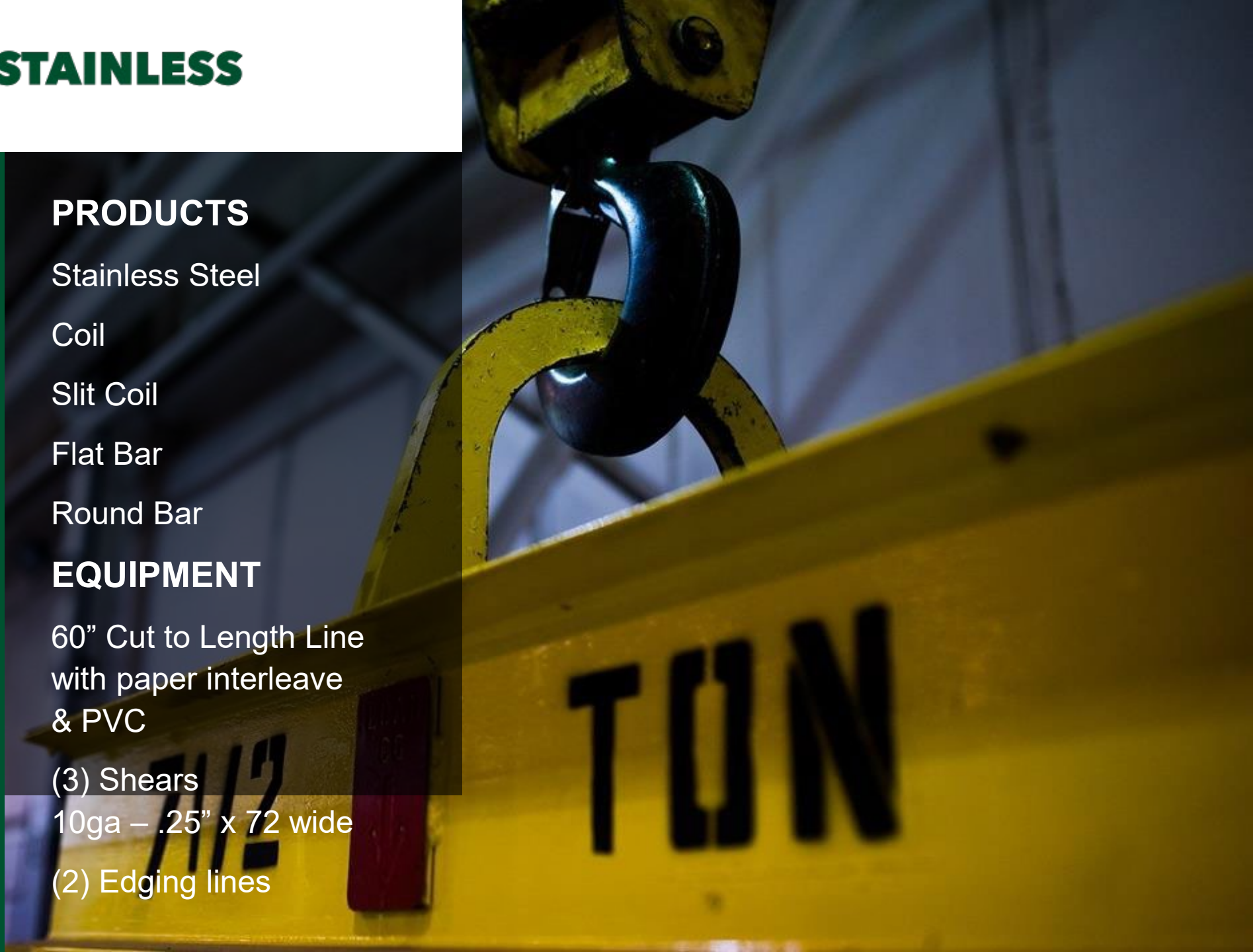



Founded in 1958

440,000 square feet

2 Fabrication and  
Warehousing Facilities

Metal-Fab provides  
complete venting  
solutions to the HVAC,  
Hearth and Plumbing  
markets, and Micro Air  
industrial air cleaning  
equipment.

3025 May Avenue  
Wichita, KS 67201

316.943.2351

mtlfab.com

## Residential and Commercial Venting Products

- Type B Gas Vent
- Temp/Guard
- Direct Vent
- Dampers
- Chimney Liners
- Grilles, Registers  
& Diffusers
- Corr/Guard
- Grease Duct
- Pressure Industrial  
Chimney

## Micro Air Industrial Air Cleaning Products

- Roto-Pulse Filter  
Cleaning System
- Dust Collectors
- Smoke Filtration



# More than a Century of Service

**1914**  
Founded:  
Chicago Tube & Iron, Chicago, IL

**1954**  
Founded:  
Olympic Steel,  
Cleveland, OH

**1956**  
Expansion:  
First Warehouse,  
Bedford Heights, OH

**1983**  
Expansion:  
Southeastern Sales  
Office, GA

**1984**  
Michael Siegal  
named CEO

**1985**  
Expansion:  
Philadelphia  
Sales Office

**1987**  
Acquisition:  
Viking Steel Co.,  
Chicago, IL

**1990**  
Acquisitions:  
Juster Steel,  
Minneapolis, MN  
Eastern Steel &  
Metal, Milford, CT

**1992**  
Expansion:  
Cleveland, OH

**1994**  
Initial Public Stock  
Offering Nasdaq:  
**ZEUS**

**1995**  
Expansions:  
Cleveland, OH and  
Minneapolis, MN

Acquisition:  
Lafayette Steel,  
Detroit, MI

**1996**  
Secondary Public  
Stock Offering

**1997**  
Expansion:  
Bettendorf, IA  
  
Acquisition:  
Southeastern  
Metal Processing,  
Winder, GA

**1998**  
Expansion:  
Chambersburg, PA

Acquisition:  
JNT Precision  
Machining,  
Chambersburg, PA

**2006**  
Expansion:  
Chambersburg, PA

**2007**  
**Surpassed  
\$1B in Sales**

**2009**  
Expansions:  
Chambersburg, PA  
and Dover, OH

**2010**  
Acquisition:  
Integrity Stainless

**2011**  
Acquisition:  
Chicago Tube & Iron

Expansions:  
Mt Sterling, KY,  
Monterrey, MX, and  
Gary, IN, 3rd Temper  
Mill commissioned

**2012**  
Expansion:  
Integrity –  
Streetsboro, OH

**2013**  
Expansions:  
Latrobe, PA and  
St. Paul, MN

**2014**  
SS market share  
eclipses 5% of  
U.S. market

**2015**  
Expansion:  
Winder, GA  
Stretch Leveling CTL

**2018**  
Acquisition:  
Berlin Metals  
  
Expansion:  
Schaumburg facility  
SS Cut to  
Length Line

**2019**  
Rick Marabito  
named CEO  
  
Acquisition:  
McCullough  
Industries – enters  
manufacturing &  
marketing of  
metal-intensive  
branded products

**2020**  
Expansion:  
New fabrication  
facility,  
Buford, GA

Acquisition:  
Action Stainless  
& Alloys

**2021**  
Acquisition:  
Shaw Stainless  
& Alloy

**Surpassed  
\$2B in Sales**

**2022**  
Expansion:  
Winder, GA  
2nd Stamping  
Press added  
  
Expansion:  
CTI facility  
Des Moines, IA  
**Record Sales  
\$2.6B**

**2023**  
Expansion:  
New Specialty  
Metals fabrication  
facility, Bartlett, IL  
  
Acquisition:  
Metal-Fab,  
Wichita, KS  
  
Acquisition:  
Chicago Tube & Iron,  
Romeoville, IL

1910

1950

1980

1990

2000

2010

2019

2021

2022

2023

# A Family of Brands

 Action Stainless

 BERLIN METALS

 Central TUBE and BAR

 CHICAGO TUBE & IRON

 EZ-Dumper®

 INTEGRITY STAINLESS

 McCullough Industries

 WRIGHT®

 METAL-FAB INC.

 SHAW STAINLESS & ALLOY

 OLYMPIC STEEL



OLYMPIC**STEEL**

---

[www.olysteel.com](http://www.olysteel.com)