



THE DAIRY PRACTICES COUNCIL®

**DPC 12
NRAES
120**

**TUNNEL VENTILATION FOR DAIRY
TIE-STALL BARNs
A COMPANION GUIDELINE TO NRAES/DPC 37
PLANNING DAIRY STALL BARNs**

Publication: DPC 12 / NRAES 120

MARCH 1998

Prepared by:

**THE DAIRY PRACTICES COUNCIL
FARM BUILDINGS & EQUIPMENT TASK FORCE**

Stanley Weeks, Director

AND

NORTHEAST REGIONAL AGRICULTURAL ENGINEERING SERVICE

Guideline Authors:

**John T. Tyson, Robert E. Graves
and Dan F. McFarland**

This Revision Sponsored by:

THE DAIRY PRACTICES COUNCIL®

Robert Turner, President

Lynn Hinckley, Vice President

Terry Musson, Executive Vice President

EXCEPTIONS FOR INDIVIDUAL STATES NOTED IN TEXT OR FOOTNOTES

Additional Guidelines may be ordered from:

<https://www.dairypc.org>

<https://www.dairypc.org/catalog/guidelines>

Tunnel Ventilation for Dairy Tie Stall Barns

A Companion Guideline to NRAES/DPC 37

Planning Dairy Stall Barns

John T. Tyson

Agricultural and Biological Engineering Department, Penn State University

Robert E. Graves, Professor

Agricultural and Biological Engineering Department, Penn State University

Dan F. McFarland

Agricultural Engineer, York County, Pennsylvania

GUIDELINE PREPARATION AND REVIEW PROCESS

The Dairy Practices Council (DPC) Guideline development and update process is unique and requires several levels of peer review. The first step starts with a *Task Force* subcommittee made up of individuals from industry, regulatory and educational institutions interested in and knowledgeable about the subject to be addressed. Drafts, called “*white copies*,” are circulated until all members of the subcommittee are satisfied with the content. The final “*white copy*” may be further distributed to the entire Task Force; DPC Executive Board; state and federal regulators; educational and industry members; and anyone else the Task Force Director and/or the DPC Executive Vice President feel would add strength to the review. Following final “*white copy*” review and corrections, the next step requires a “*yellow cover*” draft to be circulated to representatives of participating Regulatory Agencies referred to as “*Key Sanitarians*.” Key Sanitarians may suggest changes and insert footnotes if their state standards and regulations differ from the text. After final review and editing, the Guideline is distributed in the distinctive DPC “*green cover*” to DPC members and made available for purchase to others. These guidelines represent our state of the knowledge at the time they are written. Currently, DPC Guidelines are primarily distributed electronically in pdf format without colored covers, but the process and designation of the steps remains the same. Contributors listed affiliations are at the time of their contribution.

DISCLAIMER

The DPC is not responsible for the use or application of the information provided in this Guideline. It is the responsibility of the user to ensure that the information addresses their needs and that any action taken complies with appropriate regulations and standards.

DPC is a Registered Trademark of the Dairy Practices Council®

Reproduction or use in whole or in part of any text or graphic content without written permission from the DPC is prohibited.

Tunnel Ventilation for Dairy Tie Stall Barns
A Companion Guideline to NRAES/DPC 37
Planning Free Stall Barns

Table of Contents

INTRODUCTION	2
CALCULATING REQUIRED FAN CAPACITY AND INLET SIZE	3
FAN SELECTION	4
FAN INSTALLATION AND CONTROL.....	4
LOCATING INLETS AND FANS	5
TUNNEL VENTILATION SYSTEM	5
WINTERIZING TUNNEL VENTILATION SYSTEMS	6
ALTERNATIVE INLET AND FAN LOCATIONS	6
INLET ALTERNATIVES	7
FAN LOCATION ALTERNATIVES	11
SPECIAL BARNs	13

Tunnel Ventilation for Dairy Tie Stall Barns

INTRODUCTION

Shade, Air exchange (500 - 1000 cubic feet per minute (cfm) per cow), Airflow over cows (200 - 500 fpm), and plenty of cool Water (SAAW) are all important ingredients in providing hot weather cow comfort. At air temperatures above 75°F, a producing dairy cow must either decrease heat input (get in the shade or reduce feed intake) or increase heat loss (increase respiration rate, stand in a strong breeze, evaporate extra moisture from skin surface, or find a cooler location). Cows that are too hot quickly drop in milk production.

Tunnel ventilation is a special summer ventilation system that provides a combination of the high air exchange rates and high speed airflow over cows necessary for helping cows remove body heat during hot weather. Tunnel ventilation systems are not suitable for year round use because they provide inadequate fresh air distribution during low air exchange winter ventilation conditions. With tunnel ventilation, the calculation for fan capacity to provide the necessary air velocity is independent of the number of cows within the barn. The designs discussed in this guideline are best suited for two row tie stall barns with more than 40 cows. In barns with fewer than 40 cows it may be more economical to install a year round slot inlet system with capabilities of providing air exchange rates up to 1000 cfm per cow during hot weather. Tunnel ventilation systems in 2 row barns with more than 110 cows may require extra fan capacity to assure adequate air exchange for all cows.

To equip a barn for tunnel ventilation, place large exhaust fans along one end wall of the barn, and place large openings along the other end (see figure 1). Close all windows, doors or other openings along the sidewalls. The fans will pull fresh outside air through the inlet openings across the cows, exhausting hot air out the fans. A properly designed tunnel ventilation system can provide uniform air movement across the entire width of the barn. Research and experience indicates that air moving between 2.5 and 5 miles per hour will increase cow comfort at temperatures over 75°F. Velocities above 5 mph do not provide significant extra comfort or productivity. Tunnel ventilation systems are usually designed to provide air velocities inside the barn of between 220 feet per minute (2.5 mph) and 440 feet per minute (5 mph). The required fan capacity is based on the cross-sectional area (width times height) of the animal area and is independent of the number of cows in the barn. A wider barn or one with a higher ceiling will require more fan capacity to maintain the same air velocity over the cows.

Figure 1

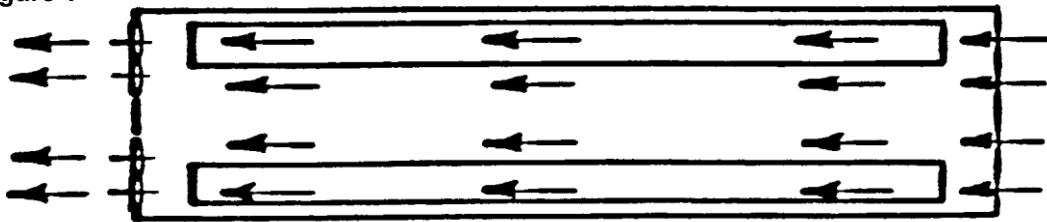

Plan view of two-row tie stall barn with air entering at one end and flowing through the barn to exhaust fans at the other end.

The critical steps in developing a tunnel ventilation system include:

- Determining fan capacity
- Determining inlet size
- Locating fans and inlets
- Selecting fans
- Installing fans and controls

CALCULATING REQUIRED FAN CAPACITY AND INLET SIZE

Tunnel ventilation designs are based on the cross-sectional area of the barn and air velocity. The **minimum air velocity** inside the barn should be 220 fpm to improve comfort, with the inlet sized at 2.5 ft² per 1000 cfm of fan capacity to provide proper inlet velocity. The required fan capacity is found by multiplying the cross-sectional area of the barn by the desired air speed. The inlet size is found by allowing approximately 2.5 ft² of inlet opening per 1000 cfm of fan capacity (or 1 sq. ft. per 400-cfm fan capacity). Finally, divide the total calculated fan capacity by the number of animals to assure that you have the desired air exchange rate per animal (500 - 1000 cfm).

Example: 70 cow tie stall barn, 38 feet wide, ceiling height 9 feet, barn length 160 feet

A. Cross-section area (width times ceiling height):

$$38 \text{ ft} \times 9 \text{ ft} = 342 \text{ ft}^2$$

B. Ventilation rate to provide 220 fpm air velocity inside barn:

$$342 \text{ ft}^2 \times 220 \text{ fpm} = 75,240 \text{ cfm (minimum)}$$

C. Inlet size:

$$75,240 \text{ cfm} \times 2.5 \text{ ft}^2/1000 \text{ cfm} = 188 \text{ ft}^2$$

D. Check ventilation rate per animal

$$75,240 \text{ cfm} / 70 \text{ animals} = 1075 \text{ cfm/animal}$$

This is well over the minimum of 500 cfm/animal.

Worksheet: _____ cow tie stall barn, _____ ft. wide, ceiling height _____ ft., barn length _____ ft.

A. Cross-section area:

$$___ \text{ ft} \times ___ \text{ ft} = _____ \text{ ft}^2$$

B. Ventilation rate to provide 220 fpm air velocity inside barn:

$$_____ \text{ ft}^2 \times 220 \text{ fpm} = ___________ \text{ cfm}$$

C. Inlet size:

$$___________ \text{ cfm} \times 2.5 \text{ ft}^2/1000 \text{ cfm} = _____ \text{ ft}^2$$

D. Check ventilation rate per animal (should be more than 500 cfm/animal)

$$___________ \text{ cfm} / _____ \text{ animals} = ___________ \text{ cfm/animal}$$

Fan and inlet requirements for tunnel ventilation of typical tie stall barns.

Barn Dimensions			2.5 mph or 220 fpm (minimum)		5 mph or 440 fpm (practical maximum)	
Width	Height	Area	Total Fan Capacity	Inlet Area (2.5ft ² /1000cfm)	Total Fan Capacity	Inlet Area (2.5ft ² /1000cfm)
(ft)	(ft)	(ft ²)	(cfm @ 1/8" spwg)	(ft ²)	(cfm @ 1/8" spwg)	(ft ²)
36	8	288	63,400	158	126,720	317
	10	360	79,200	198	158,400	396
38	8	304	66,900	167	133,800	334
	10	380	83,600	209	167,200	418
40	8	320	70,400	176	140,800	352
	10	400	88,000	220	176,000	440

Fan Selection

Select good quality, high efficiency fans. Fans will be working under load, so purchase those that deliver the desired capacity at a static pressure of 1/10" to 1/8" inch water gauge (spwg). The more air (cfm) a fan delivers for the same amount of electricity (watts), the cheaper it is to operate. For example, a 1 HP, 48" belt drive fan that was found in a supply house catalog is rated to deliver 13,000 cfm at 1/8" spwg. Another 1 HP 48" belt drive fan was found in another supplier's catalog is rated to deliver 20,000 cfm at 1/8" spwg. Ask your fan supplier for information such as cfm per watt and total cfm versus static pressure for specific fans you are considering. Be sure that the test data is given for fans with shutters, guards, or other needed accessories in place. The extra cost of high efficient fans and motors will quickly pay back in electricity savings.

In general, large diameter belt drive fans (48" or greater) should be selected. They tend to be more efficient and make less noise. All belts and blades should be guarded to protect workers, children, and animals from injury. Multiple fans provide for variation in ventilation rates and result in less loss of ventilation if a fan is broken.

Fan Installation and Control

Locate fans where they will cause minimal interference with movement of people, cows, or feeding equipment. Protect all belts, blades, pulleys, or other moving parts to be sure that people or animals do not become entangled. Anchor fans securely in place to minimize vibration.

Provide individual switches for each fan, allowing individual servicing. Also provide a properly-sized fuse, circuit breaker, or overload device for each fan that will turn off electricity to the fan should it become overloaded. Fan motors that are only protected by larger branch circuit fuses or circuit breakers may overheat and catch fire before they blow the larger fuse in the main supply panel.

Control fans manually as needed with an on/off switch, or install thermostats in the center of the barn that will begin to turn fans on as temperatures rise above 75°F. All fans should be operating if barn temperature rises above 80°F. Set thermostats so additional fans turn on at 1-2 degree intervals. Thermostats are required on any tunnel system fans that are also used for mild weather ventilation with a slot inlet system.

Locating Inlets and Fans

Ideally, inlets and fans are placed in opposite end walls at animal level (Figure 2). A continuous inlet is placed at animal level along one end wall of the barn. The fans are evenly spaced across the other end wall at cow level. However, this ideal situation very rarely occurs, especially when installing a tunnel ventilation system in an old or remodeled barn. Other buildings, banks, barn bridges, heavy stone walls, gutter cleaners, milkhouses and silos are often in the way.

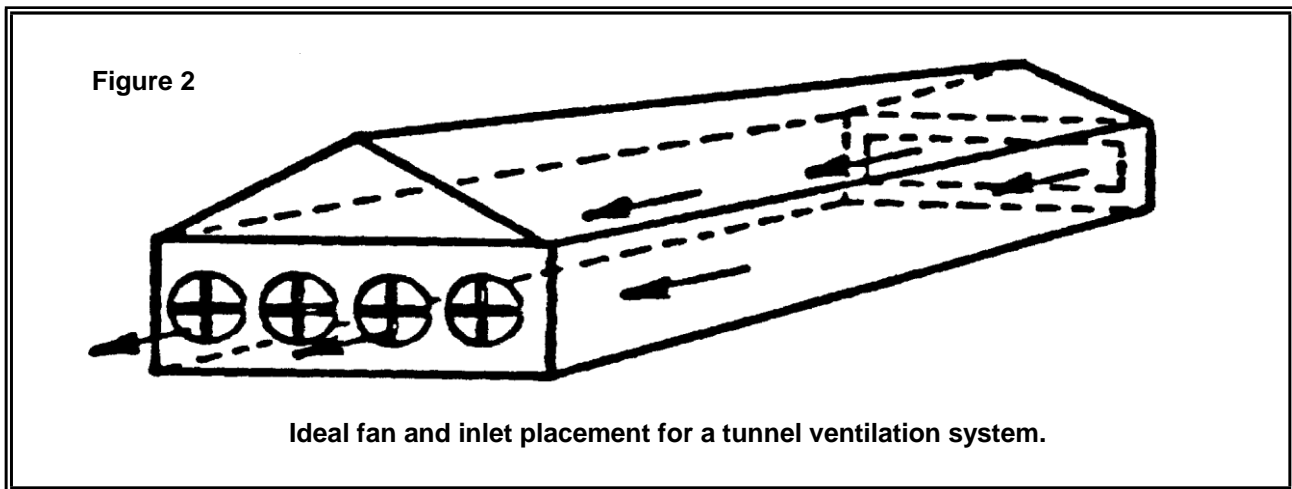

TUNNEL VENTILATION SYSTEM

The following general comments apply to any tunnel ventilation system:

- Have a plan for providing emergency ventilation or taking cows out of the barn if the tunnel ventilation system stops because of power failure. A closed up barn full of cows will warm up very quickly when fans are not operating. An alarm, flashing light or other appropriate warning device may be necessary.
- Consider fan noise and discharge of hot, smelly air when choosing fan location.
- Do not restrict any part of the airflow path through the system less than the calculated inlet area.
- Account for the area taken up by floor joists, studs, support posts, or other construction materials that pass through the opening when determining the effective area of inlets and air ducts.
- Account for loss of open space caused by screening, grates, grills or louvers. Galvanized 1 x 2 poultry wire provides protection with minimal blockage of airflow. Common window screening will block approximately 50 percent of the area even when clean and will quickly become plugged with dirt. Therefore, it is not recommended. Plastic bird meshes with wide bars may block up to 30 percent of the area.
- Inlet and fan openings for the tunnel ventilation system must be tightly closed with insulated panels during winter weather to prevent freeze up of the barn or air leakage that will affect distribution of winter ventilation air.
- Tunnel ventilation is a hot weather ventilation system and will not provide adequate air distribution at low winter ventilation levels (see figure 3). A slot inlet exhaust fan ventilation system with fresh air inlets for both rows of cows is needed for optimum winter ventilation.

Figure 3

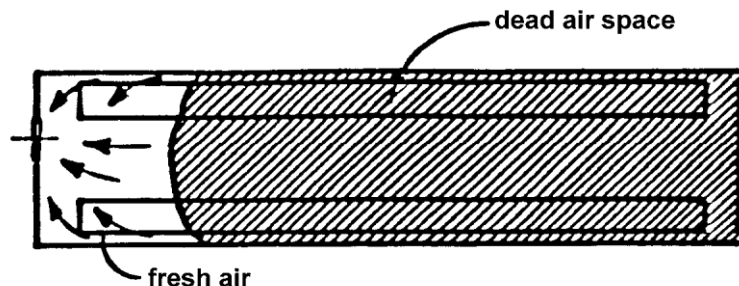

Tunnel ventilation is not a cold weather ventilation system. If it is used for winter ventilation, poor air distribution will be a problem. Enough air can filter through cracks and unplanned inlets to supply the fan(s) operating at low air exchange rates. Minimum winter ventilation rates (50 cfm/cow) may be only 5 percent of the tunnel ventilation rate. At near freezing (100-125 cfm/cow), it still may only be 10 percent of the tunnel ventilation rate. Therefore, an alternative ventilation system using sidewall fans and slot inlets is recommended for winter ventilation. Some of the tunnel ventilation fans may be used for mild weather (i.e. above 50°F outside) ventilation.

Winterizing Tunnel Ventilation Systems

The large inlet openings and fans involved with tunnel ventilation can interfere with operation of the winter slot-inlet exhaust fan system. Therefore, as part of preparing the barn for the winter, the inlet openings should be covered and sealed to prevent air leakage. Cover inlets from the mow area with panels and/or a layer of plastic sheeting and a closely stacked layer of hay bales to seal out air and provide insulation to prevent condensation. Fans that are not in use should be manually shut off or disconnected to prevent operation. A tight fitting insulated cover will prevent air leakage and condensation around the fan.

In many cases one or more of the "large" fans installed for the tunnel ventilation system can also be used to increase the air exchange of the slot inlet / sidewall exhaust fan system during mild spring and fall periods.

ALTERNATIVE INLET AND FAN LOCATIONS

Tunnel ventilation can be successful even when alternative fan or inlet locations are necessary. The areas closest to the ends of the barn will be affected most by modifying fan or inlet placement. Advanced planning and careful observation and corrections after installation can minimize performance problems. The most common problems are dead air spaces that do not have sufficient air velocity or fresh air. Additional small inlets can be used to provide fresh air to dead air spaces. Also, plywood baffles or deflectors can be located to divert airflow through dead air spaces. Following are illustrations of common problems and possible solutions. Inlet and fan design and location may be considered separately, because except in very short barns (less than 50 feet), modifying one does not affect the other's performance.

Inlet Alternatives

Figure 4

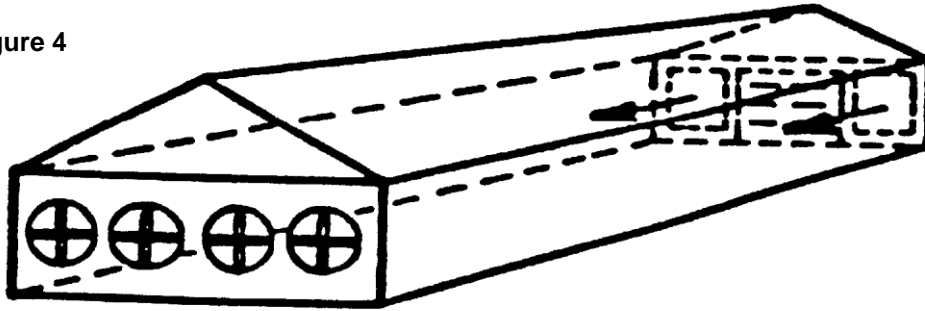

Inlets are placed on either side of an overhead door that is lined up with the center alley. Ideally, these two inlets represent the entire inlet area and are located directly in line with the two rows of cows. By placing these directly in line with the animals, it assures that all animals will feel the breeze. An adjustable curtain will allow the inlet area to be changed to match the number of fans that are operating.

Figure 5

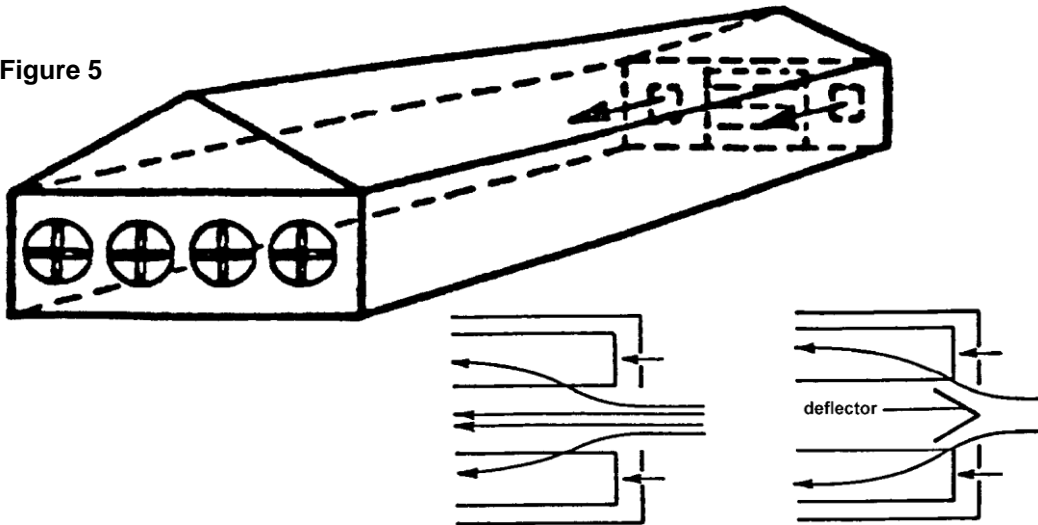

Figure 5a

Figure 5b

Openings such as an overhead door and windows may provide the proper area to cfm ratio; however, good air distribution may be lacking. In this case, most of the air will enter through the overhead door and travel part way down the center alley, leaving dead space on either side (Figure 5a). If a center overhead door is used, it may be necessary to direct the incoming air toward the outer two alleys with a V-shaped floor-to-ceiling deflector (Figure 5b).

Figure 6

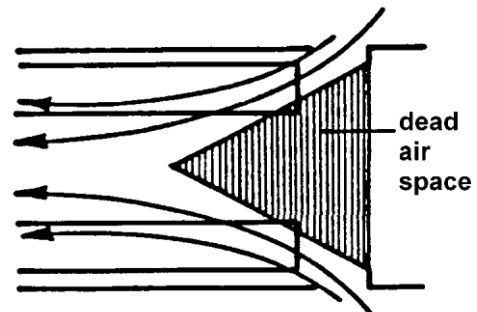
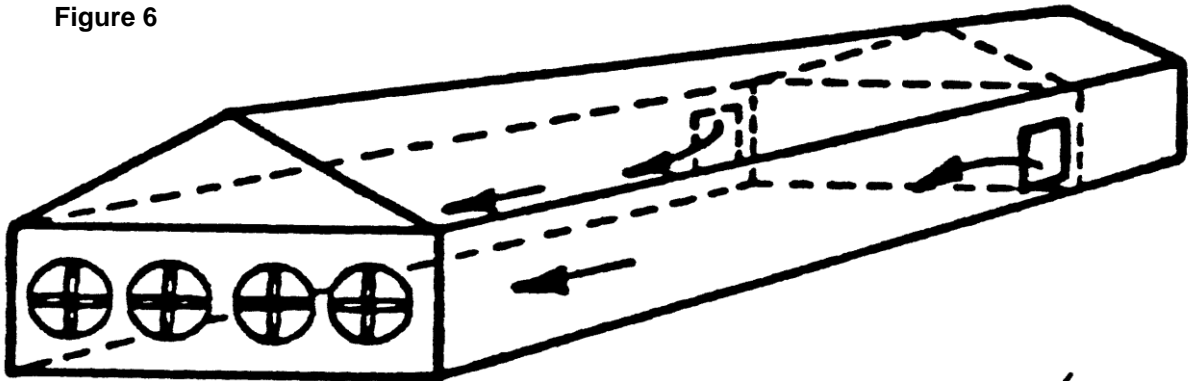

Figure 6a

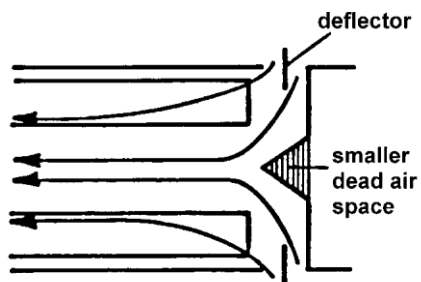

Figure 6b

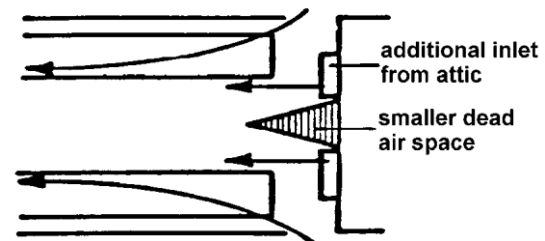

Figure 6c

If end wall inlets are not possible because of a milk house, shed, or other obstruction at the end, large side wall openings can be used. However, a dead air space may be created between the two sidewall openings (Figure 6a). Cows in this dead space will be uncomfortable. To alleviate this problem, one of two things can be done. First, deflectors can be added in the inlet to help push air toward the center of the barn (Figure 6b). Small inlets to draw additional air from the attic space or from the space at the end of the barn are another possibility (Figure 6c).

Figure 7

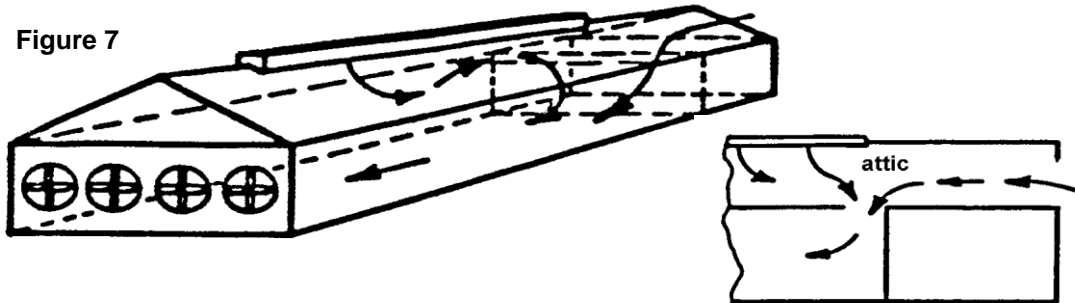

Figure 7a

Another alternative, if end wall inlets are not possible, is to draw air from the attic space over the animals. The flow of air through the attic is so large there is little effect on air temperature. Size the ceiling opening into the attic space at 2.5 ft^2 per 1000 cfm. Openings into the attic from outside should be 10 to 15 percent larger than the ceiling opening into the animal area. Adequate airflow into the attic can not be provided by simply removing the gable end from a single story barn. Inlets, dormers, or large ridge vents must also be added. If the gable end is opened it should be covered with a large opening screen to keep birds and rodents from entering, and the area blocked by the screen wires and studs must be subtracted from the total area of the opening.

Figure 8

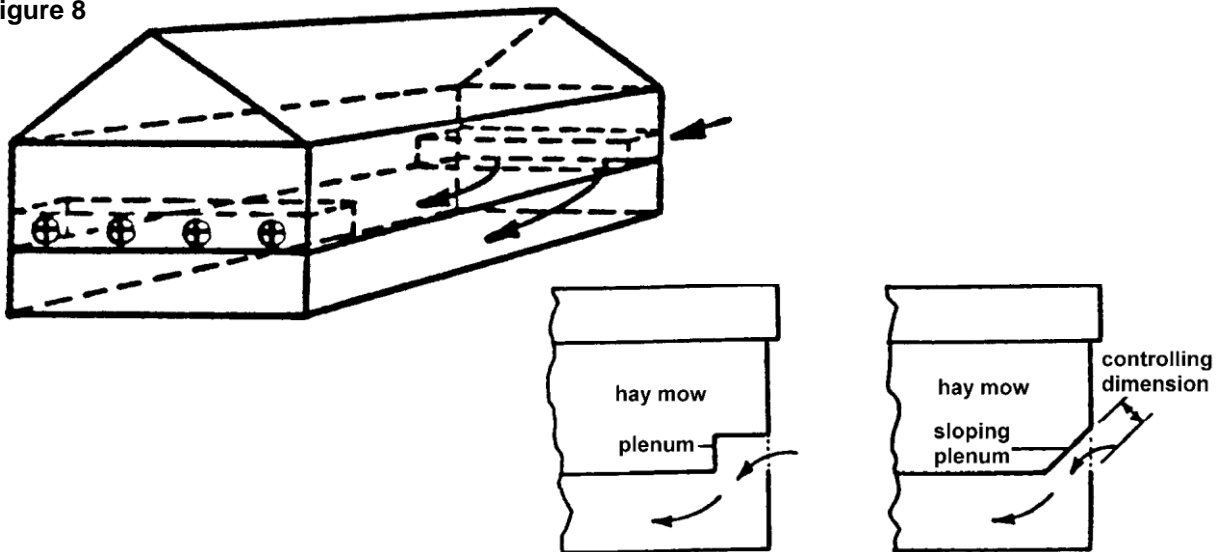

Figure 8a

Figure 8b

Two-story barns with heavy stone-end walls or one-story obstructions will require extra construction for inlets. An air plenum in the haymow will allow air to be drawn over the stone wall and into the animal area. If no obstructions exist at the end of the barn, this can be done with a simple plenum (Figure 8a). Typically, the opening from the plenum into the animal area is sized as the controlling opening. However, the area entering the plenum from outside should be at least as large as the air inlet so as not to block airflow. Consider the area occupied by floor joists, building supports, and screening when sizing the inlet area and plenum. Use sliding doors or curtain material to control the opening. If a sloping plenum is used, the shortest distance from the wall to the plenum becomes the controlling dimension (Figure 8b). If hay or other material is to be stored on the plenum, proper structural techniques must be used during design and construction.

Figure 9

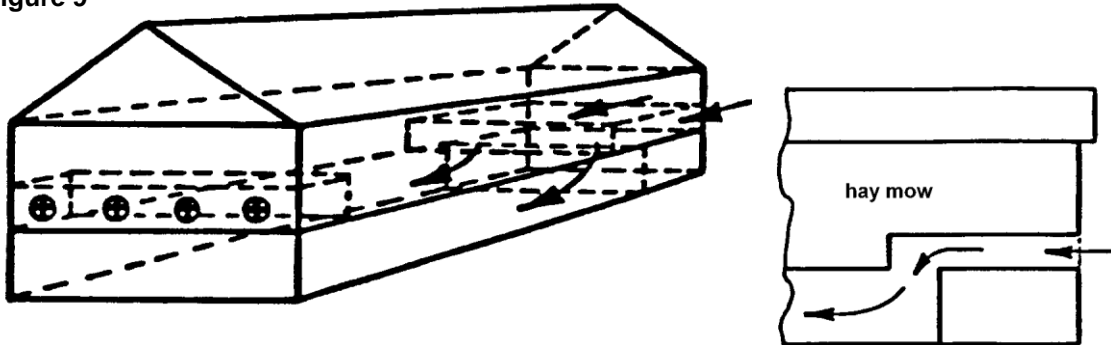

Figure 9a

If the inlet end is blocked due to a milk room or storage room, one alternative is to construct a duct over that room to the end wall (Figure 9a). Any obstructions, such as joists, support posts or screening, must be subtracted from the clear opening area. The cross-section area of the inlet duct should be slightly larger than that of the inlet itself. The opening of the duct into the animal area should be used as the control. If hay or other material is to be stored on the duct, proper structural techniques must be used during design and construction.

Figure 10

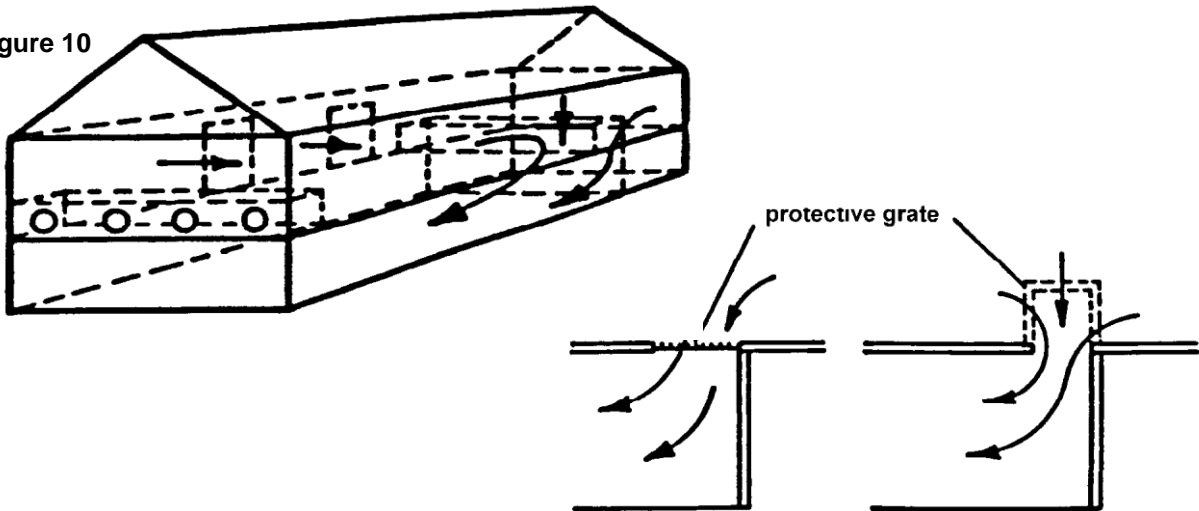

Figure 10a

Figure 10b

Another alternative is to draw air directly from the overhead storage space. If this is done, enough space must be left between the openings and the stored items. Safety also becomes a concern. Cover the floor opening with a grating or heavy screen to prevent people and animals from falling through (10a). The area of the grating or mesh must be subtracted from the clear opening. One way to do this is to construct a wooden frame or "box" over the hole and then cover the frame with mesh (Figure 10b). The floor opening into the animal space is the controlling dimension. Also, enough air must be allowed into the second story of the structure to provide the needed volume. It may be necessary to open outside doors or windows into the second story when the system is operating.

Fan Location Alternatives

Obstructions or thick stone endwalls may prevent installation of fans in the end wall at cow level as illustrated in Figure 2. The following figures describe possible alternative locations for fans.

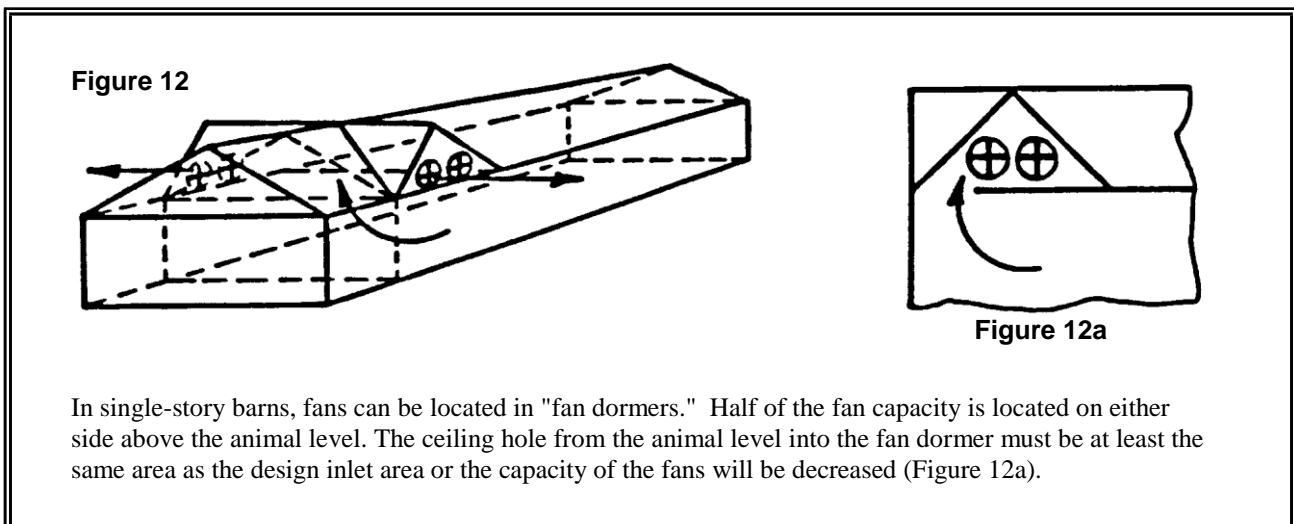
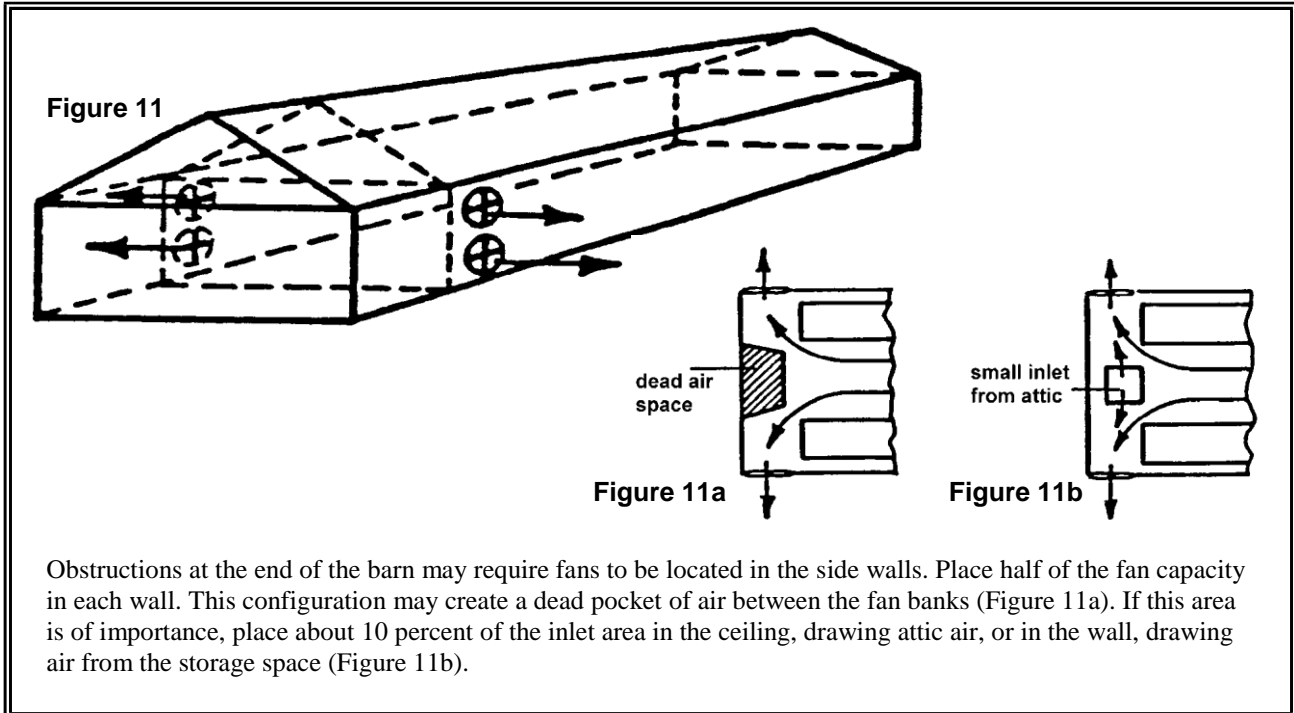

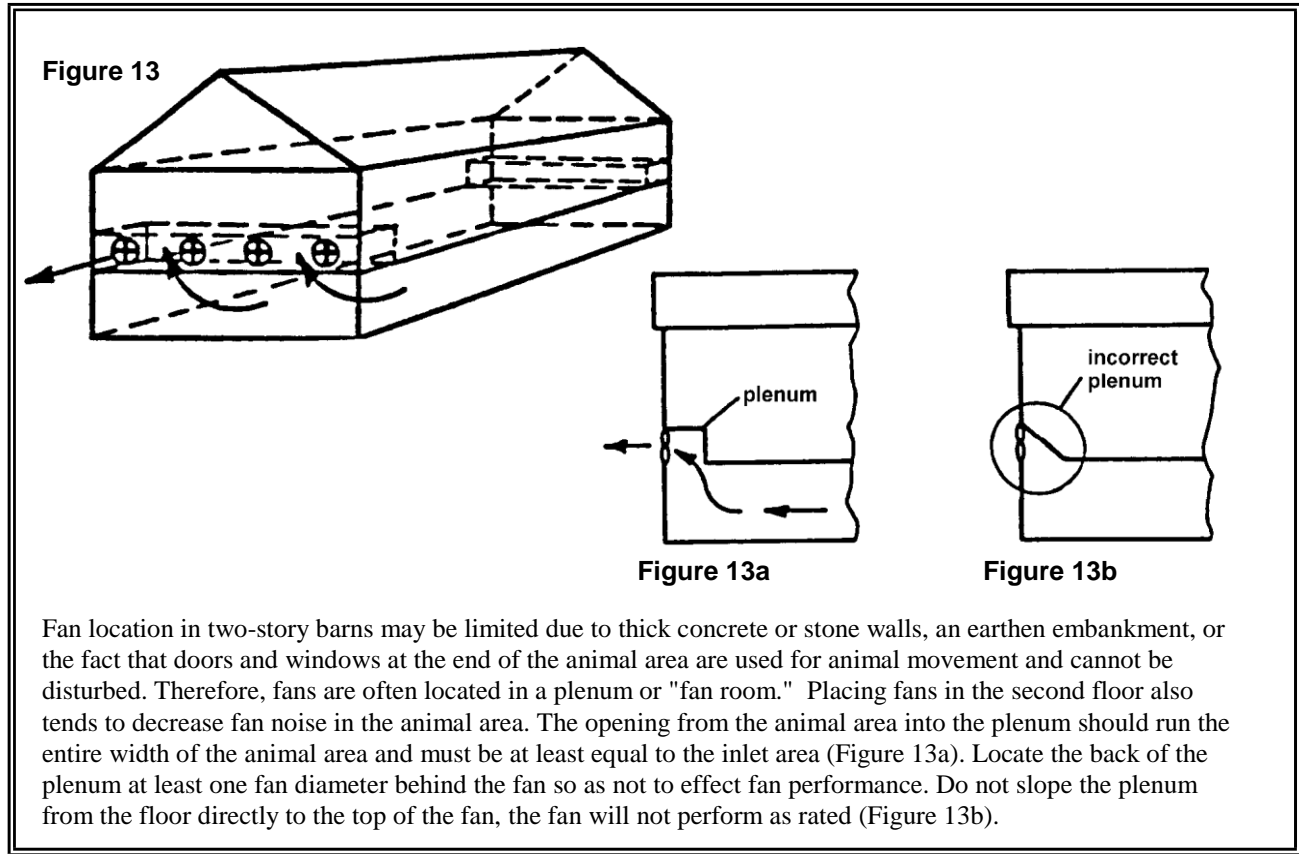

If a milk room or shed prevents fans from being placed directly in the end wall, two possible solutions exist. One is to duct air over the room to the end wall (Figure 14), and the other is to exhaust air through sidewall fans (Figures 15 and 16).

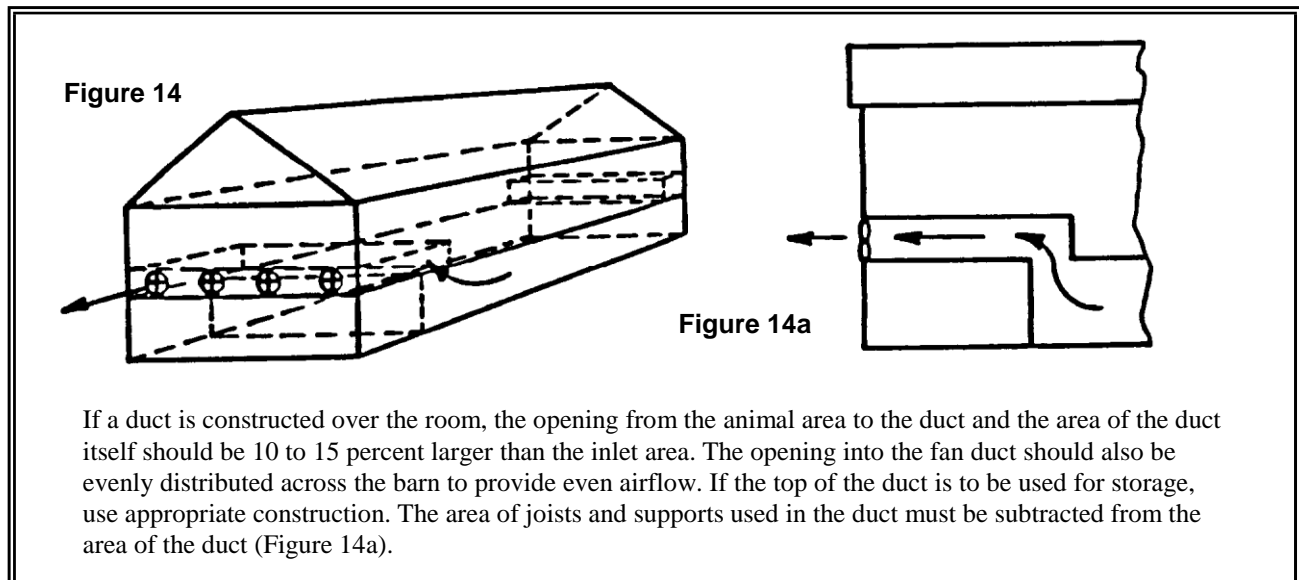

Figure 15

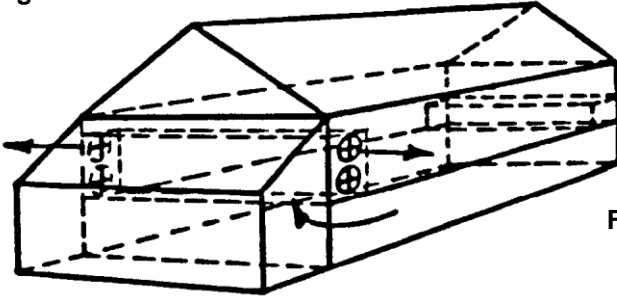

Figure 15a

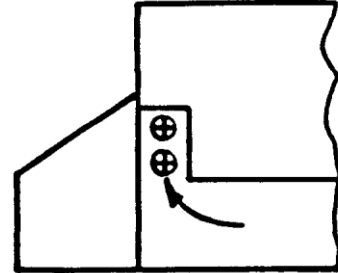

Figure 16

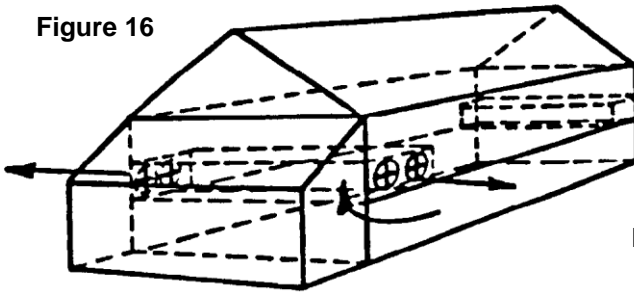
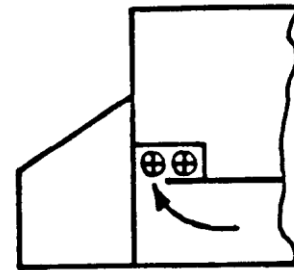

Figure 16a



If sidewall fans are used, a fan room must be constructed the full width of the barn connecting the fans with the animal space. The fans can either be positioned vertically (Figure 15) or horizontally (Figure 16). There is really little difference in the performance of the two positions and is a construction decision. The ceiling hole from the animal level into the fan room must be at least the same area as the design inlet area, or the capacity of the fans will be decreased (Figure 15a, 16a).

Special Barns

Barns that are L or T shaped are difficult to tunnel ventilate. When possible, use partitions to make rectangular spaces that can be easily ventilated. If the floor plan can not be altered, then some trial and error will be necessary to provide good ventilation in all portions of the barns.

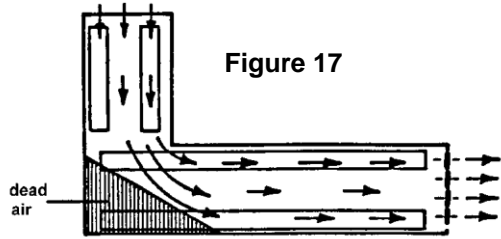

Figure 17

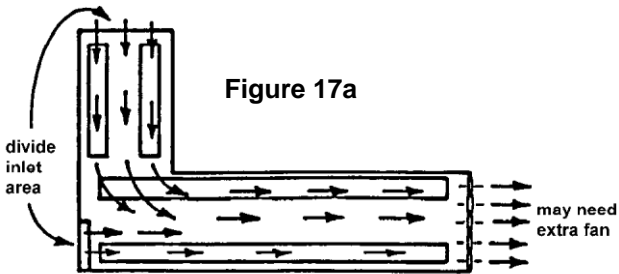

Figure 17a

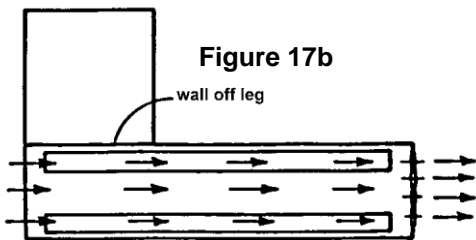

Figure 17b

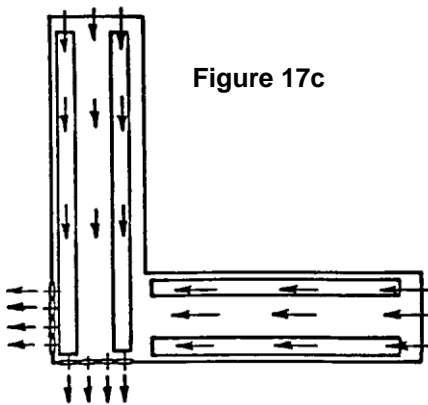

Figure 17c

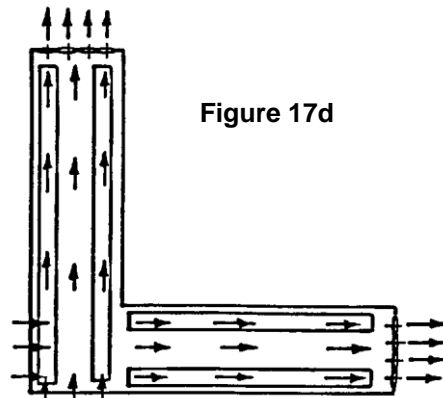

Figure 17d

L-shaped barns are a particular problem. If the legs of the L are of different lengths, fans may be placed in the long leg and inlets in the short leg. However, a dead air pocket will be created at the L as air turns the corner (Figure 17). To minimize this problem part of the inlet can be located at the base of the L to provide fresh air to the dead space. A first trial is to place 25 percent of the inlet at the base of the L and 75 percent in the end wall (Figure 17a). However, this may need to be adjusted after the system is started to get the best air distribution. This will also decrease the air velocity in the short leg of the L. It may be necessary to increase airflow rate as well as install additional inlets to provide the desired conditions in all portions of the barn.

If the shorter leg is significantly wider than the longer leg (i.e. more than 20% wider), this increases the potential size of the dead air pocket at the corner. The best alternative would be to wall off the wider leg and tunnel ventilate only the longer narrow leg and use an alternative ventilation system for the other (Figure 17b).

If both legs of the L are of equal length, another option is to place fans at the base of the L with inlets in both ends (Figure 17c) or fans in the ends and inlets at the base (Figure 17d). Each leg is designed as a separated system and works somewhat as an independent barn. This system will require twice as many fans to provide the uniform air velocity in all parts of the barn.

SUMMARY

Tunnel ventilation is an effective means of providing increased air exchange and high air velocity for improved hot weather cow comfort. A tunnel ventilation system can be easily installed in simple unobstructed rectangular barn layouts. However, with some advanced planning, creative thinking, experimenting, and modification of inlet size and location, this type of ventilation system can also be installed in barns with obstructions or unusual shapes.