

Part 3 of 3

Kennedy/Jenks Consultants
Engineers & Scientists



Water Use Efficiency Report
for
California League of Food Processors

11 February 2015

Prepared by

Kennedy/Jenks Consultants
and
Brown & Caldwell

Prepared for

California League of Food Processors
2485 Natomas Park Drive, Suite 550
Sacramento, CA 95883

Appendix E

Possible BMPs (table index)

Appendix E: Possible BMPs

General Topic	Specific BMPs Addressed	Reference ^(a)	Notes
Food Processing and Beverage manufacturing, specific	<ul style="list-style-type: none"> • Fruit and Vegetables: <ul style="list-style-type: none"> - Washing - Fluming for Transport - Processing Preparation - Equipment and Facility Cleaning - Concentrating 	CII Task Force BMPs Report to Legislature, Volume II, Section 7.2.2.3, page 221-224 2014	This section of the CII task force has one reference.
Food Processing and Beverage manufacturing, specific	<ul style="list-style-type: none"> • Conduct a survey • Look for water reuse opportunities • Employee education • Shutoff nozzles • Adjust flow rates • Clean up procedures 	CA Department of Water Resources brochures: <ul style="list-style-type: none"> • “Food Processing Industries: Water Use Efficiency Ideas” and • “Beverage Industries: Water Use Efficiency Ideas” 	Although these brochures are directed at Food Processing and Beverage industries, they are more general in nature.
Cleaning	<ul style="list-style-type: none"> • Clean in Place (CIP) BMPS • Clean out of Place (COP) BMPS • Bottle/Can/Container Cleaning • Crate and Pallet Washers 	CII Task Force BMPs Report to Legislature, Volume II, Section 7.3.4, page 298-305 2014	This section of the CII Task Force Report gave one reference (www.mksinst.com).
Cleaning	<ul style="list-style-type: none"> • Dry cleaning (i.e., waterless) • Pipe Cleaning/pigging • High pressure cleaning systems • Trigger operated controls for hoses • Selection of processing equipment • Clean in place • Scheduling product changeovers • Automatic container washers 	Pagan, Robert et. al. The UNEP Working Group for Cleaner Production in the Food Industry, <i>Eco-Efficiency Toolkit for Queensland Food Processing Industry</i> , 2004. Section 3.3, pages 68-74.	
Cleaning	<ul style="list-style-type: none"> • Cleaning and Sanitation • Transportation and Cleaning • Equipment Cleaning • Container Cleaning • Lubricating Conveyor Belts • Can and Bottle Warming and Cooling • Ingredients 	EBMUD, Water Smart Guidebook, 2008. pages PROC 1 – Proc 9	

General Topic	Specific BMPs Addressed	Reference ^(a)	Notes
Pipes and equipment	<ul style="list-style-type: none"> • Efficient spray nozzles • Optimum rate of water flow • Monitoring • Leaks 	Pagan, Robert et. al. The UNEP Working Group for Cleaner Production in the Food Industry, <i>Eco-Efficiency Toolkit for Queensland Food Processing Industry</i> , 2004. Section 3.2, pages 61-67	
Thermodynamic Processes	<ul style="list-style-type: none"> • Cooling Systems • Heating Systems – Boilers 	CII Task Force BMPs Report to Legislature, Volume II, Section 7.3.3, page 270-298 2014	This section of the CII Task Force included several dozen references.
Thermodynamic Processes	<ul style="list-style-type: none"> • Cooling Towers <ul style="list-style-type: none"> – Evaporation and Blowdown – Drift and Wind – Cycles of Concentration • Boilers and Water Heating <ul style="list-style-type: none"> – Steam Boilers – Hot Water Boilers 	EBMUD, Water Smart Guidebook, 2008. pages THERM 1 – THERM 15	
Thermodynamic Processes	<ul style="list-style-type: none"> • Blowdown in cooling towers and boilers • Cooling tower operations • Alternative cooling processes • Boilers and steam generators • Pump seals 	R Pagan, Robert et. al. The UNEP Working Group for Cleaner Production in the Food Industry, <i>Eco-Efficiency Toolkit for Queensland Food Processing Industry</i> , 2004. Section 3.4, pages 75-77	
Thermodynamic Processes	<ul style="list-style-type: none"> • Cooling Towers • Steam Generation • Refrigeration Compressors 	Brewers Association, Water and Wastewater Treatment/Volume Reduction Manual, page 30	
Water Reuse	<ul style="list-style-type: none"> • Alternate Sources of Water • Recirculated Water Use 	CII Task Force BMPs Report to Legislature, Volume II, Section 7.2.2.3, page 224-225 2014	
Water Reuse	<ul style="list-style-type: none"> • Water and Wastewater Recycling and Reuse 	Pagan, Robert et. al. The UNEP Working Group for Cleaner Production in the Food Industry, <i>Eco-Efficiency Toolkit for Queensland Food Processing Industry</i> , 2004. Section 3.9, pages 86-90	

General Topic	Specific BMPs Addressed	Reference ^(a)	Notes
Water Reuse	<ul style="list-style-type: none"> • Process water recovery and reuse 	US EPA, Technology Transfer Seminar Publication Pollution Abatement in the Fruit and Vegetable Industry. Volume 2: In Plant Control of Process Wastewater. July 1977. Pages 45-57	
Water Treatment	<ul style="list-style-type: none"> • Sediment Filtration/Removal • Softeners • Ion Exchange • Distillation • Membrane Processes 	CII Task Force BMPs Report to Legislature, Volume II, Section 7.3.8, page 2014	This section of the CII Task Force included several dozen references.
Water Treatment	<ul style="list-style-type: none"> • Evaluate need • Filtration • Ion Exchange • Softeners 	EBMUD, Water Smart Guidebook, 2008. page TREAT 1 – TREAT 6	
Summary of Key Water Efficiency BMPS	<ul style="list-style-type: none"> • List of possible water efficiency options 	Katie Bromley-Challenor, Mark Kowalski, Richard Barnard, Stephen Lynn. Technical report. "Water use in the UK food and drink industry. A review of water use in the food and drink industry in 2007 and 2010, by sub-sector and UK nations." For WRAP. July 2013. Table 75, page 101	
Summary of Key Water Efficiency BMPS	<ul style="list-style-type: none"> • List of possible water efficiency options 	WA Department of Ecology, Pollution Prevention in Fruit and Vegetable Food Processing Industries, pages 23-24	
Summary of Key Water Efficiency BMPS	<ul style="list-style-type: none"> • Recycling cooling or process water • Sequential reuse • Improved control systems • Dry cooling • Improved clean-up procedures • Etc. 	Pequod Associates, Inc. Texas Industrial Water Use Efficiency Study – Final Report. October 1993. Prepared for the Texas Water Development Board. Pages 17-19	
Alternative On-Site Sources	<ul style="list-style-type: none"> • Rainwater harvesting • Stormwater • Air Conditioner condensate • Filter and Membrane Reject Water Recovery • Foundation Drain Water • Cooling tower Blowdown • Onsite Treatment of Gray Water and Wastewater 	EBMUD, Water Smart Guidebook, 2008. page ALT 1 – ALT 7	

General Topic	Specific BMPs Addressed	Reference ^(a)	Notes
Alternative On-Site Sources	<ul style="list-style-type: none"> • Stormwater Collection 	Pagan, Robert et. al. The UNEP Working Group for Cleaner Production in the Food Industry, <i>Eco-Efficiency Toolkit for Queensland Food Processing Industry</i> , 2004. Section 3.93, page 91	
Alternative Sources	<ul style="list-style-type: none"> • Reclaimed municipal water <ul style="list-style-type: none"> - Cooling tower make-up water 	Alan Plummer Associates, Inc. State of Technology of Water Reuse. Final Report. August 2010. Prepared for the Texas Water Development Board. Page 8	
Case Study	<ul style="list-style-type: none"> • Cadbury Water Reduction <ul style="list-style-type: none"> - Grants - Water Audit - Water Recycling - Cooling tower upgrades - Retrofitting bathrooms - Rainwater harvesting - Employee education 	Australia Food and Grocery Council, "Towards Sustainability 2007-2008"	
Case Studies	<ul style="list-style-type: none"> • Case studies are integrated throughout the section 	Pagan, Robert et. al. The UNEP Working Group for Cleaner Production in the Food Industry, <i>Eco-Efficiency Toolkit for Queensland Food Processing Industry</i> , 2004. Section 3	Small paragraphs scattered throughout Section 3 of the Toolkit. Not included in Appendix F.
Case Studies	<ul style="list-style-type: none"> • Bottle Washer • Tap Room 	Brewers Association, Water and Wastewater Treatment/Volume Reduction Manual, page 30	
Case Studies	<ul style="list-style-type: none"> • Cannery Water Reduction <ul style="list-style-type: none"> - General clean-up (floors) - Can rinsing - Re-using water to wash vegetables 	"Georgia Prison 'Cans' Excess Water Use", WE&T, page 72	
Case Studies	<ul style="list-style-type: none"> • Chicken McNugget Water Reduction <ul style="list-style-type: none"> - Employee education and involvement - Water Audit - Evaluate plant process - Dry Cleanup - Product recapture/reuse 	"Reducing Water Use and Wastewater in Food Processing Plants", North Carolina Cooperative Extension Service, Water Quality and Waste Management	

General Topic	Specific BMPs Addressed	Reference ^(a)	Notes
Case Studies	<ul style="list-style-type: none"> • Fruit Cannery <ul style="list-style-type: none"> - Renovating (filtered and chlorinated) fruit canning wastewater for reuse as a finished process water supply: cleaning process equipment, conveying raw product, cooling product containers, and boiler feed - Steam generated from reclaimed wastewater evaluated for use in equipment cleaning, exhausting, and product cooking and blanching 	"Reclamation and reuse of Fruit Processing Wastewater", Summer Meeting of American Society of Agricultural Engineers, 1978	Large document, not included in Appendix F. Can provide upon request.
Case Study	<ul style="list-style-type: none"> • Poultry processor water reduction program <ul style="list-style-type: none"> - Recycling and reuse - Sideboards to prevent spillage - Counter-flow rinsing system 	Climatewise Information Bulletin. October 1996.	
Case Studies	<ul style="list-style-type: none"> • Seneca Foods – conserving water in flumes • Del Monte – reducing solids in wastewater • Company name redacted - Water shutoff for filler outfeed • Pacific Pure Aid – Boiler piping improvements to reduce water • Sierra Nevada – Waste water treatment and biogas recovery • Quincy Foods – Water reduction and reuse 	DRAFT Sustainability Micro Case Studies for Food Processors" Northwest Food Processors Association	

Note:

(a) See Appendix F for pages identified here.

Appendix F

BMPs from Literature Review

BMP Options – *Food Processing and Beverage Manufacturing*

The BMPs identified below were included based on input and expertise from representatives within the industry, experts working in the area of water conservation, and recognized studies and documents on water conservation. These BMPs are generally used and proven in industry, but they may not be applicable to every site. A specific site assessment would be needed to determine whether a particular BMP is applicable and appropriate.

General BMPs that apply commonly to the food industry can also be found in Section 7.3.4 Cleaning Industrial Vessels, Pipes, and Equipment, and Section 7.3.3 Thermodynamic Processes. Therefore, these are not described as BMPs in this section. BMPs specific to Food Processing and Beverage Manufacturing Industries are presented below:

Fruit and Vegetable Processing

Washing Operations

- Use vibration and air to help clear fruit and vegetables of debris and dirt before fluming or washing
- Use brushes to clean produce
- Spray wash instead of submerging fruits and vegetables to wash them
- Use countercurrent washing
- Reduce overflow
- Use can cooling water for first flush water

Fluming for Transport of Raw, Peeled, or Blanched Products:

- Where the fruit or vegetable will not be damaged by mechanical handling, use conveyor belts, use pneumatic systems and totes to move product instead of water.
- Use flumes with a minimum cross section to reduce water volume.
- Recirculate flume water where allowed by code.
- Use flumes with parabolic cross-sections rather than flat-bottom troughs.
- Eliminate fluming water and use dry removal of dirt.
- Sorting, culling, and grading should occur before fluming or washing. This will also reduce wastewater and save energy.

Processing Preparation, Use:

- Dry peeling and blanching
- Mechanical peeling
- Chemical peeling
- Steam blanching

Equipment and Facility Cleaning

- Reuse pump seal waste water for washing crates and pallets.
- For rinsing and cleaning cans and beverage bottles (including wine bottles):
 - Use self-closing valves and/or automatic shutoffs or sensors that only allow timed sprays run to rinse bottles and cans when they are passing the spray nozzle.
 - Clean bottles with air.
- For cleaning sweep-and-use squeegees to remove solid waste, in place of using a hose.
- For clean-in-place processes, the list below articulates methods for reducing water use:
 - Dry recovery of refuse.
 - Eliminate wet transport of wastes where possible.
 - Installing drip and catch equipment to keep floor clean.
 - Use squeegees to remove bulk waste from floor before cleaning.
 - Use floor scrubbing and vacuum systems.
 - Hand clean larger parts from equipment.
 - Place level indicators on tanks and overflow alarms on vessels.

Concentrating

When concentrating food and juices, use filtration and membrane processes as an alternative to thermal/steam operations. The following summarizes some applications of membrane processes:

- Micro-filtration for:
 - Cold sterilization of beverages
 - Clarification of fruit juices, beers, and wines
 - Continuous fermentation
 - Separation of oil-water emulsions
 - Wastewater treatment

- Use Ultra-filtration for:
 - Concentration of milk
 - Recovery of whey proteins
 - Recovery of potato starch and proteins
 - Concentration of eggs
 - Clarification of fruit juices and alcoholic beverages
- Use Nano-filtration for:
 - Removal of micro-pollutants
 - Water softening
 - Wastewater treatment
- Reverse osmosis for:
 - Desalination
 - Concentration of food juice and sugars
 - Concentration of milk¹²⁷

General

- When coring, pitting, and dicing, use dry transport and conveyor belts as an alternative to transporting product by water.
- For conveyor belt operations, investigate use of dry lubrication systems. Early attempts at dry lubrication systems were not always successful, but dry lubrication is now becoming commonplace.

Meat and Poultry Operations

The principal opportunities for reducing water use in meat and poultry processing by moving from wet to dry cleaning include:

- Dry recovery of manure, drippings, intestines, and other product waste.
- Eliminate wet transport of waste where possible.
- Install drip and catch equipment to keep floor clean.
- Use squeegees to remove bulk waste from floor before cleaning.
- Use floor scrubbing and vacuum systems.
- Hand clean larger parts of equipment.

If the meat or poultry is breaded or cooked, the following water efficiency measures can be employed:

¹²⁷ Nóra P, Pongrácz E, Myllykoski L, Keiski R. 2004. "Waste minimization and utilization in the food industry: Processing of arctic berries, and extraction of valuable compounds from juice-processing by-products."

- Use drip pans and splash guards to catch breaching or parts.
- Practice manual cleaning procedures before washing.
- Only wash equipment once dry waste has been removed.
- Many of the cooking, autoclaving, drying, and similar operations require steam. Thus, capturing and returning steam condensate represents a water saving measure.

General - Alternate Sources of Water and Recirculated Water Use

Use of alternative sources and recirculated water is a best management practice for all industries. Issues and uses specific to Food Processing and Beverage Manufacturing are discussed in this section. These BMPs may include:

- Recycling water within the plant
- Use of alternate sources for non-food processing areas
- Reuse of plant effluent for irrigation

Limitations on Water Reuse

The U.S. Federal Food and Drug Administration and the U.S. Department of Agriculture's strict guidelines for food safety often means that much of the water used in meat and poultry processing, as well as other food processing operations, may only be used once. The use of ozone and membrane treatment of wastewaters are techniques now being tested within the poultry industry, and the use of recovered water for non-contact uses such as cage cleaning, dust control, and others are now common.

Wastewater Reuse for Irrigation

One of the most important considerations is that most food processing wastewaters can be used for irrigation. Nutrients in the wastewater can help fertilize the crops, and irrigation removes pollution from receiving streams or wastewater treatment plants. When examining food processing water use, this reuse is often left out of the analysis.

Where water is to be used for crop irrigation, water quality (e.g., salts, especially sodium salts) becomes a major concern. Organic loading, irrigation rates, nutrient levels and other factors are important to consider. Many companies are using potassium salts for recharging softeners and pH adjustment, isolating waste streams with very high concentration of salts, and providing "end-of-the-pipe" treatment technologies to make their effluent usable for irrigation. (See the *Manual of Good Practice for Land Application of Food Processing/Rinse Water*. Prepared for the California League of Food Processors 2007 by Brown and Caldwell)

FOOD PROCESSING INDUSTRIES

WATER USE EFFICIENCY IDEAS



GENERAL SUGGESTIONS

Ask your local water agency about rebates or financial incentives for water use efficiency.

Appoint a water conservation coordinator with the responsibility and authority for a water use efficiency program.

Make the plant manager and other employees aware of the water conservation coordinator's duties.

Conduct contests for employees (posters, slogans, or efficiency ideas).

Install submeters and read water meters regularly (daily, weekly) to monitor success of water use efficiency efforts and to help detect leaks.

Make it way for employees to report leaks.

SURVEY THE PLANT

A plant survey helps to identify areas where water is wasted or where water could be reused.

Identify all points where water is used, including hose connections, and determine the quantity of water used at each point.

Determine the capacity of each water-containing unit (washers, flumes) and frequency of emptying.

Identify major water lines and determine the quality, quantity, and temperature of water in each.

Determine the quality of each continuous discharge not yet being re-used.

Determine flow rates in floor gutters and whether the flows are adequate to prevent solids accumulation.

Review the information developed during the survey to identify the major water-using operations and review the water re-use practices.

Develop plans to improve re-use. Evaluate the feasibility of installing cooling towers. Study the potential for screening and disinfecting reclaimed water to increase the number of times it can be re-used

MAXIMIZE WATER USE

Install high-pressure, low-volume nozzles on spray washers.

Use fogging nozzles to cool product. Inspect nozzles regularly for clogging.

Adjust pump cooling and flushing water to the required minimum.

Determine whether discharges from any operation can be re-used in other operations.

Use conveying systems that use water efficiently, such as:

- handling waste materials in a dry state
- using conveyor belts for product transport - preference should be given to those that are easy to clean
- using pneumatic conveying systems wherever possible; and use flumes with parabolic cross sections rather than flat-bottom troughs.

Establish optimum depth of product on conveyors to maximize wash water efficiency.

Replace water-intensive units with alternatives.

Divide the spray wash units into two or more sections and establish a counter flow re-use system.

Use discharge water for flushing floor gutters.

Replace high-volume hoses with high-pressure, low-volume cleaning systems.

As equipment wears out, replace with water-saving models.

Handle waste materials in a dry state when possible.

AVOID WASTE

Equip all hoses with spring-loaded shutoff nozzles. Be sure these nozzles are not removed.

Tell employees to use hoses sparingly and only when necessary.

FOOD PROCESSING INDUSTRIES

Adjust flows from recirculation systems by controlling the rate of makeup water. You can:

- Install automatic valve on the makeup line.
- Close filling line during operation.
- Provide surge tanks for each system to avoid overflow.

Turn off all flows during plant shutdowns (unless flows are essential for cleanup). Use solenoid valves to stop the flow of water when production stops. The valves could be activated by tying them into drive motor controls.

CLEANUP PROCEDURES

Sweep or shovel solid materials from the floor instead of using hoses.

Provide enough receptacles for collecting solids. Empty the receptacles frequently to prevent odor and insect problems.

Inventory all cleaning equipment (such as hoses) in the plant:

- number and types of units provided
- frequency of operation

Make sure cleaning chemicals are being used correctly.

Control belt sprays with a timer to allow for intermittent disinfection.

EXTERIOR

Don't use water to clean sidewalks, driveways, loading docks, and parking lots. Consider using mobile sweepers.

Wash cars, buses, and trucks less often.

Avoid fertilizing and pruning that would stimulate excessive growth.

Remove weeds and unhealthy plants so remaining plants can benefit from the water saved.

Adopt a water budget irrigation schedule. In many cases, older, estab-

lished plants require only infrequent irrigation.

Limit landscaping additions and alterations. In the future, design landscapes requiring less water.

Install soil moisture overrides or timers on sprinklers.

Time watering to occur in the early morning or evening when evaporation is lowest.

Make sure irrigation equipment applies water uniformly.

Mulch around plants to reduce evaporation and discourage weeds.

Remove thatch and aerate turf to encourage movement of water to the root zone.

Begin a flexible watering schedule, watering only when needed.

Avoid runoff and make sure sprinklers water just the lawn or garden, not sidewalks, driveways, or gutters.

Do not water on windy or rainy days.

Water in winter only during prolonged hot and dry periods (during spring and fall, most plants need about half the amount of water that they need during the summer).

FOR FURTHER INFORMATION

And to request this brochure in an alternate format, contact:

**California Department of
Water Resources**

Office of Water Use Efficiency

901 P Street, Third Floor

P.O. Box 942836

Sacramento, California

94236-0001

Simon Eching at:

seching@water.ca.gov

(916) 651-9667



BEVERAGE INDUSTRIES

WATER USE EFFICIENCY IDEAS



GENERAL SUGGESTIONS

Ask your local water agency about rebates or financial incentives for water use efficiency.

Appoint a water conservation coordinator with the responsibility and authority for a water use efficiency program.

Make the plant manager and other employees aware of the water conservation coordinator's duties.

Conduct contests for employees (posters, slogans, or efficiency ideas).

Install submeters and read water meters regularly (daily, weekly) to monitor success of water use efficiency efforts and to help detect leaks.

Provide an easy way for employees to report leaks.

SURVEY THE PLANT

A plant survey identifies areas where water is wasted or where water could be reused.

Identify all points where water is used, including hose connections, and determine the quantity of water used at each point.

Determine the capacity of each water-containing unit (washers, flumes) and frequency of emptying.

Determine the quality, quantity, and temperature of water carried by each major water line.

Determine the quality of each continuous discharge not yet being re-used.

Determine whether flow rates in floor gutters are adequate to prevent solids accumulation.

EVALUATE SURVEY

Identify the major water-using operations. Review the water re-use practices currently employed.

Evaluate the feasibility of installing cooling towers.

Study the potential for screening and disinfecting reclaimed water to increase the number of times it can be re-used.

MAXIMIZE WATER USE

Install high pressure, low volume nozzles on spray washers.

Use fogging nozzles to cool product. Inspect nozzles regularly for clogging.

Adjust pump-cooling and flushing-water to the minimum required.

Determine whether water discharges can be substituted for fresh water being supplied to any other operation.

Potential water re-use:

- First rinses in wash cycles
- Can shredder, bottle crusher
- Filter backflush
- Caustic dilution
- Boiler makeup
- Refrigeration equipment defrost
- Equipment cleaning, floor and gutter wash

Potential discharge re-use:

- Final rinses from tank cleaning, keg washers, and fermenters
- Bottle and can soak and rinse water
- Cooler flushwater, filter backwash
- Pasteurizer and sterilizer water

Use water-efficient conveying systems, such as:

- handling waste materials in a dry state when possible
- using conveyor belts for product transport - preference should be given to those that are much easier to clean
- using pneumatic conveying systems wherever possible; and use flumes with parabolic cross sections rather than flat-bottom troughs.

Replace high-volume hoses with high-pressure, low-volume cleaning systems.

As equipment wears out, replace with water-efficient models.

BEVERAGE INDUSTRIES

AVOID WASTE

Handle waste materials in a dry state when possible.

Equip all hoses with spring-loaded shutoff nozzles. Be sure these nozzles are not removed.

Instruct employees to use hoses sparingly and only when necessary.

Adjust flows from recirculation systems by controlling the rate of makeup water by:

- Installing automatic valve on the makeup line.
- Closing filling line during operation.
- Providing surge tanks for each system to avoid overflow.

Turn off all flows during shutdowns (unless flows are essential for cleanup). Use solenoid valves to stop the flow of water when production stops. The valves could be activated by tying them into drive motor controls.

Adjust flows in sprays and other lines to meet the minimum requirements.

CLEANUP

Sweep and shovel solid materials from the floor instead of using hoses.

Provide an adequate number of receptacles for collecting solids. Empty the receptacles often to prevent odor and insect problems.

Inventory all the plant's cleaning equipment (such as hoses):

- number and types of units provided
- frequency of operation

Check all cleaning chemicals used in the plant to determine whether they are being used correctly.

EXTERIOR

Convert from high water-using lawns, trees, and shrubs to water efficient landscapes, incorporating plants that

provide beautiful color and require less water. Design landscapes that will require less water.

Inventory water use for landscaped areas.

Water landscapes only when needed; two to three times a week is usually sufficient for lawns. Trees and shrubs require less frequent but deeper watering.

Wash cars, buses, and trucks less often.

Use a broom to clean sidewalks, driveways, loading docks, and parking lots instead of hosing down. Consider using mobile sweepers.

Avoid landscape fertilizing and pruning that would stimulate excessive growth.

Remove weeds and unhealthy plants so remaining plants can benefit from the saved water.

In many cases, older, established plants require infrequent irrigation. Look for indications of water need such as wilt, change of color, or dry soil.

Install soil moisture overrides or timers on sprinkler systems.

Time watering for the morning or evening when evaporation is lowest. Do not water on windy days.

Make sure irrigation equipment applies water uniformly.

Investigate the advantages of installing drip irrigation systems.

Mulch around plants to reduce evaporation and discourage weeds.

Remove thatch and aerate turf to encourage movement of water to the root zone.

Avoid runoff. Set sprinklers to

cover only the lawn or garden, not sidewalks, driveways, or gutters.

Water in winter only during prolonged hot and dry periods. During spring and fall, most plants need about half the water needed during the summer.

Install native vegetation landscapes that require little to no irrigation once established.

Use turf only where necessary - such as picnic and play areas.

Consider installing a recycled water system.

FOR FURTHER INFORMATION

And to request this brochure in an alternate format, contact:

**California Department of
Water Resources**

Office of Water Use Efficiency

901 P Street, Third Floor

P.O. Box 942836

Sacramento, California

94236-0001

seching@water.ca.gov

(916) 651-9667



From the table, the heat recoverable corresponding to a six percent blowdown ratio with a 150-psig boiler operating pressure is 1.7 MMBtu/hr. Since the table is based on a steam production rate of 100,000 lb/hr, the annual savings for this plant are:

Equation 7.40

$$\text{Annual Energy Savings} = [1.7 \text{ MMBtu/hr} \times (50,000 \text{ lb/hr}/100,000 \text{ lb/hr}) \times 8,000 \text{ hr/yr}]/0.80 = 8,500 \text{ MMBtu}$$

$$\text{Annual Cost Savings} = 8,500 \text{ MMBtu/yr} \times \$8.00/\text{MMBtu} = \$68,000$$

Table 7.40 - Recoverable Heat from Boiler Blowdown (MMBtu/hr)

Blowdown Rate % Boiler Feed Water	Steam Pressure, PSIG				
	50	100	150	250	300
2	0.45	0.5	0.55	0.65	0.65
4	0.90	1.0	1.1	1.3	1.3
6	1.3	1.5	1.7	1.9	2.0
8	1.7	2.0	2.2	2.6	2.7
10	2.2	2.5	2.8	3.2	3.3
20	4.4	5.0	5.6	6.4	6.6

Based on a steam production rate of 100,000 pounds per hour, 60°F makeup water & 90% heat recovery.
Source: Recovery Heat from Boiler Blowdown - www.eere.energy.gov

7.3.4 Cleaning Industrial Vessels, Pipes and Equipment

Overview

Proper cleaning and sanitation represent a critical practice for such industries as food processing and pharmaceutical and cosmetics manufacturing. For food and pharmaceutical facilities, the U.S. Food and Drug Administration, U.S. Department of Agriculture, and state and local health agencies all have regulations overseeing these processes.

Cleaning and sanitizing is one of the more human-interactive operations within a facility. The use of hoses and spray equipment, physical removal of waste materials, timing of cleaning cycles, and the way in which cleaning equipment is used, are all controlled by the employees responsible for the operation. Any modification of these cleaning and sanitizing procedures requires that employees are part of the improvements. They must be trained, be aware of the need to reduce water use, and most importantly, be allowed to participate in the accomplishments. Some cleaning techniques, such as hand cleaning, the use of spray hoses, "manual scrub and wash down," and "fill and flush" are effective,

but can use excessive amounts of water. This section examines ways to design facilities for ease of cleaning while reducing water use in the process.

Cleaning in these industries can be divided into several different areas discussed below:

- Clean in place (cleaning of pipes, tanks, processing vessels and transport tanks and trucks without taking them apart)
- Clean out of place (removing and cleaning and sanitizing parts)
- Can/bottle/package cleaning
- Crate and pallet washing
- Equipment and floor cleaning

7.3.4.1 Clean In Place

Overview – CIP

One of the most common cleaning and sanitizing operations is the cleaning of pipes, tanks, mixing vessels, cooking vessels, and other equipment that is permanently installed. Clean in place (CIP) systems use water, chemicals, and recirculation systems to clean the permanently installed pipes, vessels, and tanks. Factors that determine the cleaning effectiveness include circulation time, temperature, degree of agitation or spray action, and the formulation of cleaning solutions. Modern, efficient CIP systems typically use multiple tanks including chemical solutions tanks, and rinse water and water recirculation vessels. Multi-tank CIP systems (three or more tanks) are now considered the norm for most efficient facilities because of their water and chemical solution recovery versatility.

An example of a multi-tank CIP would be a five-tank system in a brewery that includes a caustic/surfactant tank, a phosphoric acid tank, caustic and acid wash recovery tanks, and a rinse water tank. Filtration, and even membrane processes, can also be used to clean washing fluids for reuse.

Three factors that promote water efficiency are:

- Good design
- Product recovery
- Efficient cleaning methods

Product Recovery

Maximizing the recovery of product from vessels, pipes, and tanks increases the amount of sellable product recovered and reduces the amount of material that must be cleaned. In food processing, options for product recovery include recovering edible product, recovering product for animal feed, and recovering

product for other uses. All of these have the effect of reducing the amount of water needed to clean and sanitize, as well as reduce wastewater loading.

For pipe systems, recovering product includes:

- Using air to blow product out.
- Slug or pulse rinsing, where a small initial slug or pulse of water will carry a significant concentration of recoverable product.
- Pigging, which is the process of running a device (usually a soft rubber plug) through the piping to push and squeegee the product out. Pigging requires the installation of a "launch and recovery" system that allows the rubber device to be inserted at the front end and caught and recovered at the back end. The cost of these devices depends on the size of the pipe, the type of pig, and system design characteristics. The installed cost for such devices starts at under \$20,000 but can go much higher for large diameter pipes. The product is pushed out of the pipe and can be recovered.

Ice pigging is the process of using flake ice to push the material ahead of it through the piping system. It has gained favor in some situations since the ice only needs a launcher, can be incorporated in the product, and only small amounts of ice are needed. The pig is most often pushed with water, air, or the next product to be processed. An example of a pig pushed by a product is the switch from white to chocolate milk; the pig can help separate the products in the pipe without having to waste any product.

Cost considerations for CIP include cost of product lost, cost of water, solvent, chemicals, energy used, and waste disposal. In chemical and cosmetics plants, solvent use can also lead to air quality issues.

Cleaning Methods

For both vessel and pipe cleaning, the CIP system uses a combination of several steps to clean and sanitize pipes, tanks, and other vessels. The design of these systems and the sequence of cleaning determine their water, chemical, and energy use. Most CIP systems clean with a four step process: (1) first flush, (2) chemical cleaning, (3) sanitizing, and (4) intermediate and final rinses. In the parlance of the industry, CIP systems include wash and dump systems, which are the most wasteful kind, and single and multi-tank systems, which allow for better control, water recycling, and other advantages.

- **First Flush.** The first flush is designed to flush out remaining product from the pipe or tank. As the name implies, it is a way of "getting rid of" good product. The amount and intensity of this process is directly related to the amount of product left in the pipe or vessel and the characteristics of the product being flush out. That is why product recovery is important to water efficiency.

- **Chemical Cleaning.** Chemical cleaning formulations vary with the type of product being processed. Beer stone, milk stone (solid residues left behind in beer and milk processing), and food solids are examples of materials to be removed. Cleaning formulations include alkaline and acidic detergent washes.
- **Sanitizing.** Sanitizing involves either hot water or sanitizing chemicals. Peroxides, chlorine and bromine compounds, ozone, quaternary ammonia compounds, peroxyacetic acid, iodine compounds, and anionic acids have all been used.
- **Intermediate and Final Rinsing.** Intermediate and final rinses are used to remove chemical and sanitizing agents.

Operation, Maintenance, and User Education BMPs – CIP

- Train employees in proper CIP operations
- Maintain CIP equipment according to manufacturer's specifications and/or a regular inspection and maintenance program
- Allow adequate drain time for product recovery in vessels and tanks (including transport trucks).
- Use only a small amount of water or solvent to quickly spray the vessel to encourage better drainage of product adhering to the vessel. If the amount is small enough, the product recovered can often be incorporated into the final product.
- In pipe systems, optimize turbulence, time, temperature, and chemical cleaning agents to minimize water and energy use.
- Test water regularly and discharge only when its useful life is over.

Design BMP Options – CIP

Good design in the first step in water efficient CIP systems. Type of materials used and configuration of the system will make CIP operations more efficient.

Consider the following design factors to make CIP systems more efficient:

- Ensure that piping systems do not have sharp curves, joints, bolts and protrusions, or any areas where materials being processed can accumulate. Butt and flange welding, ball valves, and long radius elbows are examples of good piping systems.
- Tanks and vessels should be easy to clean.
- Eliminate "low places" in systems where material can accumulate.
- Using only easy-to-clean materials.
- Providing good access to all areas of equipment so it can be inspected and hand cleaned where necessary.

- Installing automated cleaning procedures to ensure constant operation.

Equipment BMP Options – CIP

Multi-Tank Systems

CIP equipment can have several configurations. Old wash and dump systems have given way to multi-tank systems that carefully control water use, capture and reuse water, and treat and filter water to be recirculated within the cycle. When replacing old wash and dump systems or installing new CIP systems, choose multi-tank CIP systems. Single- and two-tank systems are not considered to be as water efficient as multiple-tank systems, and are therefore not recommended as a BMP. Membranes and other treatments may be used to maximize recirculation of water. The reuse of filtered detergent water is common. Multi-tank operations also save energy and allow maximum recirculation.

Multi-tank CIP systems are available on the market. Costs depend on the size of the equipment needed, the nature of the substances to be cleaned, and the type of vessels and pipes to be cleaned. Costs range from \$20,000 to over \$1,000,000 depending on the application. Literature indicates that water use reductions of 30 to 50 percent are possible.

Automated Controls

With all of these systems, modern control technology and real-time analytical equipment help control temperature and determine optimal detergent and chemical concentrations, as well as the amount of waste products in rinse water, all of which contribute to both energy and water efficiency. Choose new or replacement equipment with automated controls to improve water efficiency.

Product Recovery

Large Vessels and Tanks

In the chemical industry and similar non-food industries, solvent used for washing can be recovered and product separated. Where the solvent is used to carry the product, the tank purge solvent can be used for the next batch of product.

Pipe Systems

Pigging systems – launcher, sensor, and retrieve and return systems – can be purchased for \$20,000 and higher. Installation costs depend on the specific layout of the plant where installed. Water savings achieved by pigging system depend on the type of material being processed. Thick or semi-solid products, such as sour cream, are hard to rinse from pipes, so they can contaminate large volume of water. Pigging both recovers marketable material and reduces the amount of water needed to flush the product out.

Efficient Cleaning

While the overall process of efficient cleaning methods is similar for pipes, vessels, and tanks, there are some differences that need to be considered for tank and vessel systems compared to pipe systems.

Large Vessels and Tanks

- For vessels and tanks, the first step to efficient cleaning starts with good process control and, as mentioned above, good design. For process control, options to consider include optical devices to determine when rinse water is clear, level controls, and other methods ensure efficient operation.
- CIP systems for tanks and vessels typically employ spray ball technology. These devices range from simple balls with holes in them to high-pressure devices with multiple high-pressure nozzles that actuate turning devices that spray in multiple directions. The more pressure and directed force the ball has, the more efficiently it can clean. Some systems use booster pumps to increase pressure. Selection of the type of system to use depends on many factors, and many models are available. These systems are also useful for cleaning beer and wine casks, barrels, and vessels.
- CIP can also include use of manual spray hoses, including water jetting, or high-pressure sprays for hand cleaning of vessels such as tanks. These methods tend to be labor intensive, they often require entry into confined spaces, and they may consume large amounts of water, energy, and chemicals. Automated CIP systems offer many advantages.

Pipe Systems

- For pipe systems, cleaning and rinsing fluids are pumped through the pipes. Turbulence, time, temperature, and chemical cleaning agents are the factors that determine the optimum time required to clean pipe systems.

Ozone Sanitation

Example of a CIP Cycle Using Ozone

Typical 5-Step CIP Process

- Ambient temperature water rinse: removal of water-soluble residues
- Alkaline wash: removal of water-resistant residues
- Ambient-temperature or hot water and intermittent draining: removal of the bulk of the alkaline cleaning agent
- Peracetic Acid wash: neutralization of residual alkaline cleaning agent, de-mineralizes the surfaces of process equipment, and provides some corrosion control by neutralizing the caustic cleaning fluids.
- Final rinse and sanitization: hot water passed once through the circuit in bursts with intermittent drains, removing the acid cleaning agent and all other passivation residues. Final air blowing and draining.

Three-Step Ozone CIP Process

- Ambient temperature water rinses water-soluble residues from process equipment and interconnecting piping
- Alkaline wash: removal of water-resistant residues
- Ozone sanitization, rinse and flush. Final air blowing and draining

Source: Web: www.mksinst.com

In some systems, ozone can be used as a sanitizer. It is powerful, and it does not leave a residue, so rinse cycles may be eliminated, thus saving water and reducing wastewater strength. Since hot water use can often be reduced, hot water energy use may be reduced, but energy is also needed to produce ozone. Ozone applications require a benefit to cost analysis to determine their economic applicability on a case-by-case basis.

7.3.4.2 Clean Out of Place

Overview – COP

As the name implies, clean-out-of-place (COP) equipment is taken apart and washed. The simplest systems consist of vats that parts are placed in for hand cleaning. Modern equipment includes tunnel, cabinet, and emersion tank mechanical recirculation systems, as well as ultrasonic cleaning.

Operation, Maintenance, and User Education BMPs – COP

- As with CIP, It is important to test the water regularly so it is not discharged until its useful life is over. It is also important to minimize the vat size.
- Employee training and awareness helps workers' pay attention to small details.

Equipment BMP Options – COP

- The pharmaceutical industry commonly uses automated systems with verification-of-cleaning software. These systems may be applicable in other industries as well.
- Sanitizing baths (clean water with sanitizer) are often used to "soak" parts. Again, analyzing the water is important so sanitizer strength can be maintained instead of dumping. Sanitizer water can also be reused as first flush rinse water or even as wash water for the parts to be cleaned or for floor and area washing.
- The use of whitewater or ozone for cleaning and sanitizing offers opportunities to reduce the amount of rinse water needed in cleaning operations. Since hot water use can often be reduced, hot water energy use may be reduced, but energy is also needed to produce ozone. Ozone applications require a benefit to cost analysis to determine their economic applicability on a case-by-case basis.

7.3.4.3 Bottle/Can/Container Cleaning

Overview – Bottle/Can/Container Cleaning

The use of disposable bottles and cans has eliminated the dominance that returnable bottles used to have in the market. However, new bottles and cans can still contain foreign debris.

Bottle washers have two basic configurations: soaker washers and hydro-spray-washers. Steps in pre-used bottle washing include:

- Pre-rinse
- Label removal
- Caustic wash
- Rinse

Water use depends on such variables as the type of bottle being washed and the organic matter in the bottle.

General BMPs – *Bottle/Can/Container Cleaning*

- Water efficiency can be achieved through caustic water recovery, recirculation of final rinse water for caustic makeup, and reuse of water for the pre-rinse and label removal stages.
- For bottle washing systems, the water used for first flushing can often be recovered and reused.
- Membrane technology can also be used in some instances to recover water and chemicals used in the bottle washing process.
- Air blowing to clean new bottles saves water while ensuring that particles are removed before the bottles are filled.

7.3.4.4 Crate and Pallet Washers

Overview – *Crate and Pallet Washers*

Crates and pallets are integral parts of the food processing industry. Although they do not come into direct contact with the food, they need to be cleaned and kept free of debris so they do not soil the food containers. Crate and pallet washers have much in common with commercial dishwashers and laboratory cage washers. While both tunnel and cabinet washers are in use, tunnel washers are more common in larger operations. Tub, tote (wheeled container), and basket washers are also used. Baskets allow liquids to drain while tubs and totes are designed to contain liquids.

Equipment BMP Options – *Crate and Pallet Washers*

Water efficiency standards for crate and pallet washers have not been established. The company purchasing this equipment should compare equipment because these systems use significant volumes of water, energy, and detergent.

- Crate washers and pallet washers should be designed to recirculate water within the individual wash phases and to capture and reuse final rinse water for wash water use.
- Tunnel washers offer both water and energy saving potential. High-volume efficient models use five stages of cleaning. The pallets or

3.3 Reducing demand for water: cleaning

A large proportion of many food processors' water use is for cleaning equipment and surrounding areas of the plant. This can range from less than 10% of total water use for a 'dry' process such as nut processing, up to well over 40% for a meat processor or a dairy. There are numerous opportunities for reducing water use in cleaning, as this section outlines.

'One of the surprising findings of the eco-efficiency assessment was the amount of water consumed for cleaning, around 51%, in addition to a further 19% on the flume line. The installation of a second fume washer to enable the reuse of sanitiser water, the attachment of auto shut-off valves on hoses, and a very successful staff awareness program linked to an incentive scheme has seen water consumption on the site reduced by 15.7%.'

David May (Chief Operations Officer) Harvest FreshCuts 2003

3.3.1 Dry cleaning

Dry cleaning not only reduces water and chemical use, but also reduces the volume of wastewater and improves its quality. As much product as possible should therefore be removed from plant and equipment using dry cleaning techniques before washdown. Wet and dry industrial vacuums can be used in most factories for easy collection and transfer of solids. In some cases usable product can also be recovered.

Although dry cleaning is practised widely in many businesses, there may still be room for improvement. Operator training and commitment are key factors in achieving good dry cleaning. Behavioural changes for manual cleaning can be achieved by raising awareness of water conservation issues, and perhaps also by incentive schemes.

Scrubber and vacuum cleaners can wet or dry clean and remove gross soiling before washing with water, to reduce the amount of wastewater that would normally be discharged to the drain. These cleaners are fast and efficient, and reduce chemical use; but they may be unsuitable for small areas, or areas with restricted access.

Case studies

Dry cleaning: poultry processor, Australia

Bartter Enterprises in New South Wales reduced its water consumption by 10 000 L a day by mopping and sweeping where possible instead of hosing. Minimising the need to flush out drains by preventing build-up saved a further 3000 L per day.¹

Dry cleaning of floors and equipment: chicken nugget processor, USA

The Equity Group in North Carolina produces chicken nuggets for McDonald's restaurants. By using dry cleaning methods to remove all dry waste from the floor and equipment, the Equity group was able to reduce BOD levels in the wastewater by 50%.²

¹ NSW Department of State and Regional Development

² Carawan 1996



Eco-efficiency action

- Sweep, squeegee or vacuum-clean floors and equipment to remove solids before washing down.
- Design or install drip trays or lips onto equipment and benches to help reduce the amount of material finding its way onto the floor and down drains. Trays and tubs should be easy to empty, and emptied regularly.
- Use scrapers, brushes and vacuum devices to pre-clean containers, equipment and conveyors before washing.
- Consider the use of scrubber dryers or vacuum cleaners to clean large areas of floor space.

3.3.2 Pipe cleaning

Pipes are usually cleaned manually or with a 'clean-in-place' system. Before any wet cleaning commences as much product should be removed as possible, to avoid increasing wastewater loads and wasting product. 'Pigging' systems or low-pressure blowers that propel a 'pig' (usually a solid material plug) to push out product can often be used to clear pipes. Pigs are particularly useful for the removal of viscous liquids, but usually need specifically designed or modified pipework because the pig cannot get through pumps or valve clusters.

The design of pipes and pipe run also affects cleaning efficiency. Pipes should not be oversized for the job and should be installed with a 'fall' leading to a drain point. They should be designed with minimal bends and dead legs where contamination can occur. Smaller pipework can be more easily vacuumed or air-purged of product.

Case studies

Line pigging and vacuuming of sumps: jam processor, UK

Nelsons of Aintree vacuum-cleans its sumps, gulleys and food traps and has installed a new pigging system. The amount of water used to flush the pipeline has now fallen from 2020 kL/year to 310 kL/year. In addition, 173 tonnes of saleable product is recovered annually. The COD level of the site's effluent has fallen by 76%. The payback period was only 4.2 weeks.¹

Line pigging: toppings, syrups and blends processor, Australia

Food Spectrum in Queensland produces stabilised fruit product which is used as an ingredient in syrups and other food products. The stabilised fruit is pasteurised in a heat exchanger before being packed. Formerly, the lines were flushed with water at the end of each product run, producing a water product interface that was packed off and blended with other product batches. After this the pasteuriser underwent a 10 minute water rinse which was sent to drain. Food Spectrum has previously used starch plugs and pigs to reduce this interface, with varying degrees of success. A change to the pasteuriser allowed the company to introduce a new silicon rubber pig that better adheres to the pipework, thereby eliminating the need for flushing between product batches. This has avoided the use of about 10 minutes of water rinsing per batch and saved around \$700 per year in water supply and discharge costs. The new system enabled about 7300 kg of product, worth \$14 600, to be recovered.²

¹ Envirowise 2000d

² UNEP Working Group for Cleaner Production 2003d



Eco-efficiency action

- Investigate the use of 'pigging' systems or low-pressure blowers in pipelines to push out product.
- Optimise the time spent flushing pipes for cleaning and rinsing.
- Consider pipe design and layout for new installations to optimise cleaning needs.

3.3.3 High-pressure cleaning systems

High-pressure water cleaners are often used to clean floors and equipment. Cleaning with high-pressure water can use up to 60% less water, compared with using hoses attached to the water main (Envirowise 1998b). Mobile high-pressure cleaners can have flow rates ranging from 4 L/min to 20 L/min and pressures of up to 500 kPa.

It is important, however, that high-pressure cleaners complement cleaning procedures, and they should not be used in place of dry cleaning. In some 'high-risk' factories high-pressure cleaners can create aerosols, possibly causing the deposition of micro-organisms from the floor and drains back onto equipment and product. The use of high-pressure cleaning systems may therefore not be suitable in some instances and, if they are used, should be used carefully.

Case study

High-pressure cleaning systems: Mexican processor, USA

Sparta Foods in North Carolina replaced its water main pressure hoses with high-pressure cleaners to clean the equipment used to process flour products. The equipment can now be cleaned using half the quantity of water. The payback period was less than three months.¹



¹ Carawan 1996

Eco-efficiency action

- Replace mains-pressure hoses used for cleaning floors and open equipment with high-pressure washers.
- Reduce the time to set up mobile pressure washers by fixing them to a ring main.

3.3.4 Trigger-operated controls for hoses

A hose left on unnecessarily for a total of one hour a day can waste between 470 kL and 940 kL of water in a year. That represents \$1090–2180 a year per hose. The cost of a trigger gun can range from \$20 to \$100 for a heavy-duty item. Staff may need to be encouraged to use trigger guns, as they may consider them cumbersome, and possibly more susceptible to damage than open-ended hoses.*

Case studies

Trigger-operated controls on hoses: syrup, toppings and blends processor, Australia

Food Spectrum in Queensland fitted trigger-operated controls on all hoses used for cleaning, reducing water consumption for cleaning by 10%.¹

Trigger-operated controls on hoses: poultry processor, Australia

Bartter Enterprises in New South Wales reduced its water consumption by 30 000 L per day by investing \$1000 in efficient hose nozzles. This resulted in a saving of \$19 000 annually.²



¹ UNEP Working Group for Cleaner Production 2003d

² NSW Department of State and Regional Development 2003

Eco-efficiency action

- Fit trigger-operated controls or water guns on hoses so that, wherever practicable, they are turned off immediately after use or when unattended.
- Install automatic reel-up hoses to help protect the hose and its trigger gun.

'To leave a 3/4 inch hose running on the floor can cost more each hour than paying the person that left it there.'

Marcus Cordingley, Environmental Systems Coordinator, Golden Circle

*Assumptions: \$2.33 kL for true water cost; 260 days each year; hose flow rate of 0.5–1.0 L/s

3.3.5 Design and selection of processing equipment

Processing equipment should be designed to promote easy cleaning. This will reduce consumption of water and chemicals, as well as reducing the time taken to clean equipment. When selecting processing equipment give preference to those items that have fewer moving parts and are easier to clean. Keep in mind what difficulties operators may have in using and cleaning the equipment.

Case study

Redesigning pipework to reduce cleaning requirements: brewery, Australia

The South Australian Brewing Company's old cellar area had a long pipe run and complicated manifold system, which meant that extensive cleaning was required between batches. A new pipe layout was designed with waste reduction in mind. The new design saved \$55 000 in water, beer, energy and cleaning, plus a further \$10 000 in wastewater savings. The payback period was less than one year.¹

¹ South Australian Environmental Protection Agency 1999



Eco-efficiency action

Ensure equipment allows easy access for cleaning, to avoid excessive use of chemicals and water. Ensure that all internal angles and corners are smooth and curved, and there are no exposed fasteners or rough welding at joins. All equipment should be self-draining and contain no dead legs.

3.3.6 'Clean-in-place' systems

A 'clean-in-place' (CIP) system is an automatically operated cleaning system that is designed to clean tanks, piping or other items of equipment. A CIP system usually consists of several chemical and rinse water-holding tanks, and associated pumps and piping to allow the recirculation of rinse waters and cleaning chemicals. A well-designed system minimises the use of water and chemicals, and saves labour required for manual cleaning. CIP systems are usually custom designed for specific applications.

Spray balls and nozzles are frequently used as part of a CIP system. Spray nozzles for tank cleaning usually come in three main types:

- fluid-driven tank wash nozzles that are rotated by the reactionary force of the fluid leaving the nozzle
- motor-driven tank washers controlled by air or electric motors, which rotate the spray head for high-impact cleaning
- stationary tank wash nozzles or spray balls which use a cluster of nozzles in a fixed position.

Spray balls and nozzles should be selected to suit the application, particularly with regard to the spray pattern and the temperature and corrosive nature of the cleaning fluids. More information on efficient spray nozzles can be found in Section 3.2.1.

Case studies

Reuse of water by CIP system: milk processor, Australia

Pauls Ltd previously utilised a single-use CIP system where all water and chemicals were used once and then discharged to waste. The system has been replaced with a multi-use CIP system that recycles final rinse water for the pre-rinse cycle. All chemicals used in the system are also returned and circulated through holding vats, where temperature and conductivity are monitored and automatically adjusted to meet specifications. The new CIP system saves Pauls \$40 000 annually, with a payback period of only one year.¹

Reuse of water by CIP system: fruit and vegetable processor, Australia

Golden Circle in Queensland conducted trials on its hot fill/cordial line designated CIP unit and found that the second-step rinse could be eliminated by extending the time for the first rinse. Eliminating the second rinse could save around 1700 kL or \$4000 a year. The installation of an additional CIP tank would allow final rinses to be collected and used as a first rinse on the next wash. This would save 4350 kL per year and an additional \$10 300.²

¹ Environment Australia 2003b

² UNEP Working Group for Cleaner Production 2003f



Eco-efficiency action

- Use sensors to shut off rinse water as soon as the solids (waste or product) have been washed out, and to avoid detergent wash cycle water from being diverted prematurely to the drain.
- Design CIP systems to allow for storage of rinse water and recovery of chemicals for reuse.
- Use membrane filtration to recover recirculated solution, thereby reducing the need to drain and refill storage tanks regularly.
- Review the operation of existing CIP systems to determine whether the settings are optimum.
- Consider 'pulsed' rinses which can reduce water usage.
- Investigate automatic 'proof of clean' checks for your system.
- Review cleaning needs (e.g. a full clean versus a simple rinse).
- Contact your supplier to determine the most suitable spray nozzle for your cleaning needs.
- Ensure the spray ball or nozzle fits the application, especially with regard to spray pattern and temperature, and chemical corrosion of materials

3.3.7 Scheduling product changeovers

If equipment needs to be cleaned after each product changeover, modify or schedule production so that the number of product changes is kept to a minimum. It may be possible to reduce or eliminate the amount of cleaning required between changeovers by processing similar products sequentially. For example, schedule more highly flavoured or dark products last.



Eco-efficiency action

- Schedule product changeovers to reduce or eliminate cleaning requirements.
- Improve production scheduling to ensure that washers are used only when fully loaded.

3.3.8 Automatic container washers

Automatic container washers can vary from front-loading automatic washers for small quantities to large conveyor washer systems. Washers are designed to carry out various duties including soaking, pre-washing, washing, rinsing, disinfecting and sometimes drying. Automatic container washers can achieve water savings of up to 95% when compared with pressure cleaning, as shown in Table 3.6.

Table 3.6: Comparison between using an automatic tray washer and using a high-pressure hose and gun to clean 2500 dirty trays each day

	Tray washer	Pressure washing
Water used (kL/day)	1	27.5
Time required (h)	6	21.0

Envirowise 1998b

Case study

Recycling wash water and system control on container washer: cordial, jams and toppings processor, Australia

Schweppes Cottee's in New South Wales has installed a collection tank, piping and pump on a cordial line container washer to enable the reuse of final rinse water for 'first wash' water. It has been estimated that the system has halved the washer's consumption of mains water.¹

¹ Environment Australia 2003a



Eco-efficiency action

- Investigate using purpose-built automatic washers to clean containers, rather than using hoses or high-pressure cleaning methods.
- Reuse final rinse water for pre-rinse cycles in washers. If the washer already reuses water, ensure that fresh water is kept mostly for the final rinse, rather than for other sections of the process.
- Investigate adjusting the washer speed and length of cleaning cycles, to achieve the most efficient clean while still meeting hygiene standards.

Process Water

Water used by industries and businesses to produce a product or affect a process is known as “process water.” This section discusses the following industries and their uses of process water:

- food and beverages
- auto repair and service
- paper manufacturing
- metal finishing

The chapter will not cover opportunities to save water by using efficient plumbing fixtures and irrigation systems, since these are covered elsewhere in this report.

While much of the information herein is specific to the product being manufactured or service being provided, the potential to design water conservation into the process ranges from simply adjusting the equipment or process to use less water to adopting new practices or processes that use no water at all.

Food-and-Beverage Processing

The food-and-beverage-processing industry includes a wide range of products and manufacturing processes:

- bakery/pastry shops
- industrial bakeries
- breweries
- wineries
- soft drink and juice manufacturers
- dairy-food processors
- meat, fish, and poultry processing
- frozen-food producers
- canneries
- snack-food manufacturers
- grocery stores and restaurants that produce food products for sale
- other food and drink processors

The food-and-beverage industry uses water for many purposes. The quality and purity of the water is of primary concern since it is used to make products that will be consumed. Water is also used to clean and sanitize floors, processing equipment, containers, vessels, and the raw food products prior to their processing. Hot water, steam, cooling, and refrigeration also require source water. Designing and building a facility that has a reduced requirement for water includes:

- designing the facility for ease of cleaning
- providing adequate metering, submetering, and process control
- taking advantage of dry methods for cleanup and transport

Few industrial processes involve no need for water. In every industry that uses water, careful planning and design can minimize water waste and optimize the benefits received from the water that is consumed.

- using product- and byproduct-recovery systems
- incorporating water reuse and recycling
- designing for minimal or no water use

Description of End-Use and Water-Savings Examples

Because of the complicated and highly varied nature of the food and beverage manufacturing industry, providing a simple guide to water efficiency that covers all types of facilities is not possible. Before beginning this discussion of water conservation in food processing, one should remember that health and sanitation are overriding concerns. All actions to reduce water use must be measured against this primary consideration.

The following example illustrates ways water can be used in the soft-drink industry. Potable water is first treated to soften it and, if needed, to remove additional minerals. It is chilled and blended with flavorings and sweeteners, then carbonated. Cans or bottles are filled and sealed, then rinsed and sent through a warming bath to avoid creating condensate in the open air and ensure they are dry before packing. The eight major water-using processes are:

- water softening, which requires periodic filter backwash
- water included in the product
- water to clean and rinse cans
- water to warm cans after processing
- water sprayed on the conveyor line as a lubricant
- water to operate cooling towers for refrigeration equipment and boilers for heat
- water to sanitize and clean the plant and vessels
- water for employee sanitation, irrigation, etc. (North Carolina Department of Environment, Health, and Natural Resources, 1998).

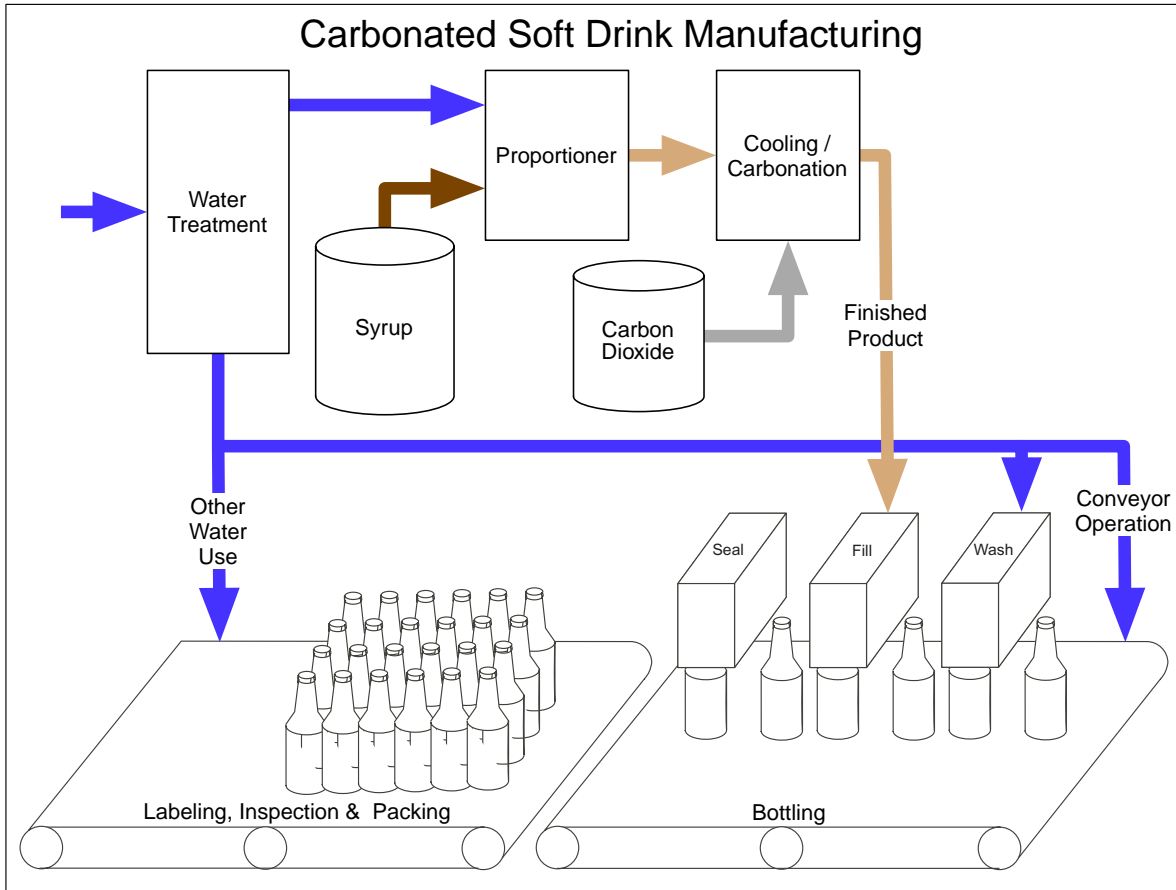

Based upon concise.britannica.com/ebc/art-54000

Each of eight major water-using activities in the food- and beverage-manufacturing sector will be described, along with examples from specific industries where appropriate:

- cleaning and sanitation
- thermodynamic processes
- transportation and cleaning of food products
- equipment cleaning
- container (bottles, cans, cartons, etc.) cleaning
- lubricating can and bottle conveyor belts
- can and bottle warming and cooling
- product ingredients

Cleaning and Sanitation

Information on floor cleaning and the cleaning of outdoor areas is found in all sectors (see “Food Service”). Dry cleanup, preventing spills by controlling processing equipment and leaks, and proper storage and handling of ingredients all reduce water needed for cleaning.

The following table summarizes the importance of water for cleaning in four food-processing sectors (Environmental Technology Best Practices Program).

Water Use by Major Food-Processing Types

Type of Process	Percent of Water for Cleaning
Bakery	70
Soft drink	48
Brewing	45
Jam	22

Thermodynamic Processes

Another common use of water is in the production of steam and hot water and in cooling towers, as discussed in the section on Thermodynamic Processes. Metering and submetering are important in understanding how much water is used in each process or type of equipment. Proper process controls are essential to managing water and energy use.

Transportation and Cleaning of Food Products

The use of flumes to both transport and clean produce (fruits and vegetables) is common. Water is also used in the cleaning and processing of meat, poultry, and fish. Common water-conservation techniques begin with reducing water use by:

- recycling transport water
- adjusting design of flumes to minimize water use
- using flumes with parabolic cross sections
- providing surge tanks to avoid water loss
- using float control valves on makeup lines
- use solenoid valves to shut off water when equipment stops

All these techniques can reduce the need for water, but changing the process has even more potential.

- Replace fluming with conveyor belts, pneumatic systems, or other dry techniques to move food products.
- Install sprays to wash food.
- Use mechanical disks and brushes.
- Install counter-flow washing systems.
- Control sprays on belts.
- Control process equipment to reduce waste.

Grocery stores and smaller bakeries should follow good food-service sector washing practices for meats, fruits, vegetables, and other food products before final packaging. Further, ensure that all water-using process equipment has proper level and flow controls (Costello).

As an example, a Minnesota vegetable-processing firm reduced water use for conveying corn by 20 percent, or 1,000 gpd, just by employing proper controls and recycling 20 percent of the water in the flumes (North Carolina Department of Environment and Natural Resources).

Equipment Cleaning

Equipment to be cleaned ranges from large process facilities and equipment to the hand-held equipment and cooking utensils found in smaller bakeries and grocery stores. Smaller utensils should be washed following the ware-washing considerations found in the “Food Service” section. Larger equipment that cannot be disassembled easily must be cleaned in place. Choices of procedures for cleaning equipment can yield multiple advantages including:

- product recovery
- reduced wastewater loading
- reduced water use
- reduced chemical use

Good design and layout of equipment are essential to easy cleaning.

- Design equipment that minimizes spills, leaks, and residual product that must be removed before cleaning.
- For closed systems such as tanks and piping, eliminate “low spots” so equipment can easily and completely drain.
- Provide easy access to all areas of the equipment that must be cleaned.
- Select materials and surfaces that are easily cleaned.
- Change procedures to reduce the need for cleaning.

As an example, a medium-sized bakery in Minnesota used 65 to 100 buckets a day for storing icing. Washing these buckets required approximately three hours of labor each day, and icing that stuck to the bottom and sides was wasted. They replaced the one-bucket-at-a-time preparation method with a large vat. This reduced the number of containers that had to be washed to three large ones and saved up to \$2,000 a year in icing that was being wasted. It also reduced washing time from three hours a day to a few minutes, thus saving water (Minnesota Technical Assistance Program).

Clean-in-place methods range from flooding the equipment with hot water, detergent, and chemicals, to dry cleaning. Dry cleaning as a first step is essential for saving water, since it reduces the water needed in the wet-cleaning phase, sometimes eliminating it completely. Dry cleaning includes:

- removing as much otherwise-wasted product as possible by pouring and storage for future use
- scraping equipment and vessels to remove as much waste as possible

- using dry brushes, cloths, and paper towels to remove waste
- using wet towels

Dry cleaning can be labor intensive, but the labor costs are offset by the potential to recover product, reduce pollution loading, and potentially clean equipment more thoroughly. It also allows employees to closely examine equipment and discover possible mechanical problems at an early stage.

Where water is used for cleaning, it is important to employ the “multiple aliquots” concept, in which it is better to use a number of smaller volumes of water to clean than one very large volume. For mixers, extrusion and molding equipment, conveyor belts, and other open equipment to which one can gain direct access, cleaning should start with physical removal of residual materials and then be followed by wet washing. Four principles of wet cleaning are:

- use high-pressure, low-volume sprays
- install shutoffs on all cleaning equipment
- use detergents and sanitizing chemicals that are easily removed with minimum water
- install and locate drains and sumps so water and wastes enter quickly to prevent the use of a hose as a broom

For closed vessels, pipes, and delivery tubs, cleaning techniques are very different. They require “Clean in Place” (CIP) and “Sanitize in Place” (SIP) methods. Before cleaning a process piping system, it is essential to remove as much of the product as possible. At its simplest, this involves draining the tank or piping system. Designing the piping to eliminate low spots that can trap product is a major aid in this process. Following this, several methods can be employed to remove extra product and clean the vessel and piping. For piping, three methods find common use, including:

- slug rinsing
- air blowing
- “pigging”

Pigging is a process in which a flexible rubber or plastic projectile is forced through a pipe to push the product out. In Europe a technique using “ice pigging” has recently been developed that uses ice slurry. The pig is forced through the pipe with air, water, or cleaning fluids. CIP systems can also be designed to reuse water and chemicals, if product safety allows.

For vessels, a ball that sprays water in all directions has historically been employed for washing. Replacing that with a high-pressure, low-volume rotating spray that washes product down the sides can reduce the amount of water needed. In many cases, this dilute first rinse can be captured and product recovered. In the dairy industry, pasteurization tanks must be filled with hot water after cleaning to pre-pasteurize the vessels. This water is often captured and reused as wash water for other CIP needs, thus saving both water and energy, since the water is already hot.

Vessel-, barrel-, and cask-cleaning water can also be used for irrigation in the winery industry and, to some extent, in the brewing and vegetable- and fruit-processing industries. The use of this water for irrigation also removes solids and BOD from the waste stream and places it where it becomes an asset to growing plant material.

Container (Bottles, Cans, Cartons, etc.) Cleaning

Cleaning bottles, cans, and containers prior to filling is common throughout the industry. For returnable bottles, the use of air bursts to remove loose debris and materials and the reuse of water from can

warming and other operations are common ways to reduce water use. Other methods include use of pressure sprays and steam instead of high-volumes of hot water to clean containers.

One brewery recovered the bottle wash water and used it for washing the crates in which the bottles are placed. This saved more than 4,500 gallons of water a day (Hagler).

Cleaning cans, bottles, and containers after they have been filled offers other opportunities. Some spillage and overfilling is inevitable, but with proper equipment control this can be minimized. Reducing water use to a minimum and passing the wash water through nanofiltration can recover both the sugars and product for use as animal feed or for growing yeast, while the water is cleaned and made available for additional reuse.

Lubricating Can and Bottle Conveyor Belts

One of the most unusual uses of water in the food and beverage industry is as a lubricant for conveyor belts that move cans and bottles, so they can “slip” easily on the high-speed conveyor belts and not tip over. This water is softened and mixed with biocides and soaps before it is sprayed onto the conveyors. Many attempts have been made to use dry lubrication systems or find other ways to move the cans and bottles at the high speeds needed in modern operations, but the use of water as a lubricant remains the standard for this industry. Many have been able to reduce water use or even capture and recover belt lubricant water. In Australia, eight Cadbury Schweppes plants are testing dry lubricant conveyor systems (Smart Water Fund of Australia). For now, ensuring that the spray nozzles are properly sized, well aligned, and equipped with automatic shutoffs is the best that can be done.

Can and Bottle Warming and Cooling

Water has a variety of applications, ranging from cooling or heating cans to use as a heat-transfer agent. This water remains relatively clean and is an excellent source of water for reuse. Water is used to cool cans after they have been removed from pressure cookers in the canning process. In most cases this water is cooled in a cooling tower or a refrigeration unit that employs a cooling tower in the process. In the warming process, cans and bottles from the beverage industry that have been filled with cold liquids are heated so condensate does not form on them and they dry more quickly before packing. These operations offer significant opportunities for reuse for almost all of the other water needs in the operation, except where potable quality is required by regulation. Examples of reuse include:

- first rinse in the wash cycle
- can and bottle shredder and crusher operations
- filter backwash for product filters
- chemical-mixing water
- defrosting of refrigeration coils
- use for equipment or floor cleaning
- flushing out shipment containers and crates
- cleaning of transport truck and rail cars
- gutter and sewer flushing
- fluming and washing of fruits and vegetables
- makeup water for conveyor lubrication systems
- irrigation
- cooling-tower makeup water

Product Ingredients

Most food products contain water and, in the case of the beverage industry, water is usually a major component of the product. To both reduce water use and loading on wastewater systems requires proper instrumentation and control of filling and packaging operations. The solid waste by-products of brewery, winery, fruit and vegetable processing, and meat processing operations, as examples, can often be used as animal feed or be rendered for other uses. Liquid wastes can also find use in other industries, for example, fruit juice by-product can be used to produce alcohol.

Water-Savings Potential

Examples of practices and water savings are provided above. Because of the varied nature of the products and processes found in the food-and-beverage-processing industry, water-savings potential is slightly different for each. These six design principles will help build water efficiency into a facility:

- design the facility for ease of cleaning
- provide adequate metering, submetering, and process control
- set up the facility to take advantage of dry methods for cleanup and transport
- use product and by-product recovery systems
- incorporate water reuse and recycling
- design for minimal or no water use

Cost-Effectiveness Analysis

Because of the highly varied nature of the food-and-beverage-manufacturing industry, a cost analysis across the industry is not possible. However, several cost areas need to be taken into consideration, including these seven:

- water
- wastewater disposal
- pretreatment
- chemicals for cleaning and sanitizing
- solid waste handling
- energy
- potential to produce a marketable by-product

Recommendations

Proven Practices for Superior Performance

- Require that new facilities provide a list of possible areas of water recovery and reuse.
- Require that all major water-using areas be separately metered.
- Require automatic shutoff and solenoid valves on all hoses and water-using equipment, where applicable.

Additional Practices That Achieve Significant Savings

- Use pigging, air blowing, or slug washing as part of CIP systems for process pipes.
- Use floor cleaning and vacuum machines where possible.
- Minimize the use of water-lubricated conveyor belts.
- Minimize the need to use a hose as a broom by installing drains close to areas where liquid discharges are expected.
- Provide pressure-washing equipment in place of washdown hoses.

References

A&B Processing Systems (201 South Wisconsin Ave, Stratford, Wisconsin). **A Guide to Clean In Place (CIP).**

_____. **Product Recovery Systems (Pigging Systems) in the Process Industry.**

Aquacraft, Inc. for the California Department of Water Resources and U.S. Bureau of Reclamation. 2003. **Demonstration of Water Conservation Opportunities in Urban Supermarkets.**

Carawan, Roy E. **Liquid Assets for Your Bakery.** March 1966. North Carolina Cooperative Extension Service Publication No. CD-41.

Commonwealth of Pennsylvania. Department of Environmental Protection. **Water Conservation Ideas for the Beverage Industry.**

Costello, Jim. Spring 2001. "Brewing Up Prevention Ideas." **Newsletter.** University of Minnesota Technical Assistance Program.

Encyclopedia Britannica. "Carbonated Soft-Drink Manufacturing." concise.britannica.com/ebc/art-54000.

Environmental Technology Best Practices Program. **Reducing the Cost of Cleaning in the Food and Drink Industry.** Report No. GG 157. www.etsu.com/etbpp/.

GDS Associates, Chris Brown Consulting, Axiom-Blair Engineering, Inc., Tony Gregg, PE. 2004. **Water Conservation Best Management Practices Guide.** Texas Water Development Board. Austin, Texas.

Galitsky, Christian. 2004. **Best Winery: An Integrated Benchmarking and Energy and Water Management Tool.** Lawrence Berkeley National Laboratory.

Hagler Bailey Consulting. 1997. **Pollution Prevention Diagnostic Assessment — Brewery.** United States Office for International Development. Office of Environmental and Natural Resources.

Hoffman, H. W. (Bill). March 2006. **Building Reduced Water and Wastewater Cost into the Design.** Austin Water Utility. Austin, Texas.

Kentish, Graeme, and Morgan, Peter. October 2006. **Conversion of Product Conveyors from Wet Lubrication to Dry Lubrication.** Cadbury Schweppes, Tullamarie, Victoria, Australia.

Maryland Department of the Environment. **Water Saving Tips for Food Processing Facilities.**

_____. **Water Saving Tips for the Beverage Industry.**

Massachusetts Water Resources Authority. "Beverage/Food Processing Industries." **Water Conservation Bulletin No. 3.**

Minnesota Technical Assistance Program. October 2004. **Best Management Practices — Bakery.** University of Minnesota.

North Carolina Department of Environment and Natural Resources, Division of Pollution Prevention.
August 1998. **Water Efficiency Manual for Commercial, Industrial, and Institutional Facilities.**

Ogunbameru, Gus, Ph.C., Ch.E. 2004. **Best Management Practices for Selected Industries and Additional Resources.** Massachusetts Office of Technical Assistance.

Platts Research and Consulting. 2002. **Management of Energy Cost in Grocery Stores.** McGraw Hill Companies, Inc.

Rausch, Kent D, and Powell, Morgan G. 1997. **Dairy Processing Methods to Reduce Water Use and Liquid Waste Load.** Cooperative Extension Service. Kansas State University. Manhattan, Kansas.

North Carolina Department of Environment, Health, and Natural Resources. August 1995. **A Soft Drink Bottling Company — North Carolina.**

Smart Water Fund of Australia. 2007. “Cadbury Schweppes Australia & New Zealand aims to save over 20,000 kilolitres of water each year thanks to the Smart Water Fund.” www.smartwater.com.au.

Automotive Services

The automotive service and repair industry is one of the most ubiquitous types of commercial enterprises in any city. Establishments include:

- service stations
- oil change/lubrication
- body repair
- tune-up shops
- full-service repair shops
- fleet maintenance
- tire service

The design of a water-efficient shop depends to some extent upon the type of service offered. New air-quality regulations have also meant that shops have switched from solvent-based parts- and brake-cleaning systems to aqueous-based systems. Floor-cleaning with dry methods, preventing spills and leaks from entering the wastewater discharge system, and the proper design of oil separators have as much



Aqueous Parts Washer

fastt.navsea.navy.daps.dla.mil/frames/rec_4.htm

to do with pollution prevention as they do with water conservation. Washing of vehicles is covered in a separate section.

Description of End-Use and Water-Savings Potential

Three areas of operation offer both reduced water- and pollution-loading possibilities:

- proper design of aqueous parts- and brake-cleaning
- preventing pollution and reducing water use in shop-floor cleaning
- proper handling of spent fluids and oils

3.2 Reducing demand for water: processing

3.2.1 Efficient spray nozzles

Water spray nozzles can be used in food processing for cleaning, conveyor lubrication or cooling heated product. Savings in water consumption can be achieved by reviewing spray and jet technology.

Spray nozzles come in hundreds of different models that are designed to suit particular needs. In recent years new technology has produced designs that allow for reduced water use without compromising spray effectiveness. Selection factors include type of spray pattern, water flow rate, spray pressure, drop size and alignment. Improved nozzles are also better equipped to tolerate reuse of dirtier water without becoming blocked. Considering the low cost, it makes sense to take advantage of the water-saving opportunities that the correct selection provides. Other factors affecting efficiency include the condition of the spray nozzles (worn or heavily scaled nozzles are inefficient) and correct placement to ensure the most effective spray pattern. The durability of nozzles is also important, as water consumption increases with nozzle wear. Table 3.4 shows how flow rate increases with wear for nozzles made of different materials. Stainless steel and nylon are the most durable.

Table 3.4: Comparison of different nozzle materials

Material	Abrasion resistance ratio	Flow increase from wear after 25 h of use (%)	Flow increase from wear after 50 h of use (%)
Aluminium	1	21	26
Brass	1	15	17
Stainless steel	4–6	4	4
Nylon	6–8	3	3
Hardened stainless steel	10–15	1	1

Source: Spray Systems Co. 2003

Case studies

Water-efficient spray nozzles: Cordial, jams and toppings processor, Australia

Schweppes Cottee's in New South Wales replaced the existing shower-style nozzles on their cordial container wash systems with water-saving nozzles and now save 7950 kL of water annually. The payback period was 10 weeks.¹

Water-efficient spray nozzles: milk and beverage processor, USA

Schroeder Milk Co. in Minnesota now saves around 20 000 L daily after improving the efficiency of spray nozzles on their carton washer. The company changed from using shower heads and spray bars to smaller nozzles and mist sprays and now only operates the washer when needed, instead of continuously.²

Redesign of spray nozzles to better focus spray: brewery, UK

Carlsberg-Tetley Burton Brewery replaced the existing rotating head spray nozzle with a fine non-rotating slit spray nozzle that forced water through at high pressure. The new nozzle has better water contact with the cask to ensure a more thorough wash. The nozzle is also more water efficient and reliable, and requires less maintenance.³

¹ Environment Australia 2003a

² University of Minnesota 2003

³ Envirowise 1996b



Eco-efficiency action

Review the effectiveness and efficiency of spray nozzles by:

- monitoring and conducting regular maintenance to ensure nozzles are kept in good condition
- conducting trials to determine the optimum settings (e.g. the minimum flow rate required for the spray to effectively clean equipment); the correct selection and maintenance of nozzles will have a bearing on the flow rate
- checking placement and alignment (e.g. a nozzle placed too high above the product will dissipate and be less effective); sprays should also be carefully spaced to avoid overlap.

3.2.2 Optimum rate of water flow

Sometimes equipment operates at water pressures or flow rates that are variable or set higher than is necessary. Conduct trials to determine the optimum flow for the equipment, or compare the flow rate with manufacturers' specifications to see if the flow can be reduced. To maintain a constant and optimum flow rate consider installing flow regulators.

Case study

Flow regulators on filleting benches: fish processor, UK

GW Latus installed flow regulators on the water pipes supplying its filleting benches. The flow rate was reduced from a variable 13 L/min to a consistent 8 L/min. An annual saving of A\$7950 was achieved.¹

¹ Envirowise 1999c



Eco-efficiency action

- Check the manufacturers' specifications for all water-using equipment and investigate whether the flow rate is higher than specified.
- For variable flow rates consider whether it is better to use a manual flow control valve set to the optimum rate.
- Consider installing a block valve where control valves are used to isolate a water supply and are then not being reset to the optimum rate. It may be necessary to lock the valve so that it is accessible to designated personnel only.

3.2.3 Monitoring and process control devices

Installing automatic monitoring and control devices in key sites can lower production costs.

Many devices are available to measure level, flow, temperature, pH, conductivity and turbidity. It is essential that process controls are correctly calibrated.

Water flow control

Water sprays are often used in food processing for washing, or to lubricate equipment. Avoid the use of continuous water sprays that can be left running unnecessarily during breaks in production. Linking sprays to conveyor or equipment motors using automatic cut-off switches can help eliminate water wastage.

Case studies

Control of water flow to a conveyor belt using solenoid valve: fish processor, UK

After installing meters on their equipment, F Smales and Sons found that the pre-wash stage in their filleting process was using excessive amounts of water. By fitting a solenoid valve to switch off the water supply to the conveyor belt when it was not in use they were able to reduce pre-washing water use by 40%.¹

Control of water flow to chilling and washing system using thermocouple: meat processor, United Kingdom

Thermocouples were installed on the water inlet and outlet to a chilling and washing system to feed into a control valve which optimised the flow rate of water. Supply water to the chilling and washer system was reduced by 10%.²

¹ Envirowise 1999c

² Envirowise 1999b

Level control

Inadequate level control cause product or water to overflow into the drain, generating unnecessary wastewater. The installation of simple process control instrumentation, as well as good design of processing equipment, can help reduce waste by preventing spills.

Case studies

Overflow control system: brewery, Australia

Castlemaine Perkins in Queensland installed an overflow control system on the hot water tanks of a keg line to prevent the loss of hot water to drain during filling. The initiative saves the company 30 000 kL annually.¹

Redesign of outlet weir: poultry processor, Australia

Joe's Poultry Processors in South Australia produces smoked and ready-to-eat poultry. By redesigning the outlet weir on a scalding tank that was wasting 35 L of water per minute in overflow, the company was able to reduce water wastage by 55%. The payback period was 3.5 months.²

Modification of cooler: fruit and vegetable processor, Australia

Hot-filled bottled fruit juice is cooled before being labelled and packed. The cooler has three stages, separated by baffles or weirs. Water entering the third stage of the cooler was not equalising quickly enough, and consequently a significant volume of water overflowed to the floor and to wastewater. By installing a pipe to allow the water to equalise more quickly and preventing the overflow, the company will now save around 6660 kL of water — an annual saving of \$34 000 including supply, treatment and discharge costs. The installation cost was only \$400.³

Detection and repair of faulty valves on bottle washer: brewery, UK

Three faulty valves were causing the water tanks in a bottle washer to continuously overflow. By replacing the valves, JW Lees and Co. were able to save approximately A\$32 500 in water and wastewater charges annually. The payback period was two months.⁴

¹ Castlemaine Perkins 2003

² Environment Australia 1997b

³ UNEP Working Group for Cleaner Production 2003f

⁴ Envirowise 1996a

Other process instrumentation

There is a wide variety of process instrumentation available to help food processors optimise product yield and minimise waste. For example pH, conductivity and turbidity sensors are widely used to detect product, chemical and water interfaces, particularly in clean-in-place systems. Such sensors can prevent product, chemicals and water from being prematurely diverted to drain and can allow for recovery of valuable resources. Differential pressure sensors can be used instead of timers or manual operators to detect pressure drops. For example, a pressure sensor across a filter cleaning system can be used to initiate cleaning only when needed, thus optimising the use of water and chemicals.

Case study

Pressure sensors replace timer: fruit processor, UK

A fruit processor used filters to remove pulp before bottling. The filters were cleaned at regular intervals determined by a timer. The timer was replaced with differential pressure sensors, and filter cleaning was initiated only when necessary. This reduced water consumption by 30%.¹

Interface detection reduces beer loss and wastewater charges: brewery, UK

A UK brewery was losing beer worth more than A\$2 300 000 annually in its wastewater. A waste audit revealed that 80% of all beer losses were from a vessel that separated the beer from the dead yeast cells. The process was modified with a capacitance level switch to enable better detection between the two phases. The company now saves around \$1 800 000 annually in recovered beer and reduced wastewater charges. The payback period was only five days.²

¹ Envirowise 1999a

² *ibid.*



Eco-efficiency action

- Investigate at what stages in processing water is being used, and how this can be minimised to reduce the volume of wastewater generated. Consider whether better process control could be used to reduce losses, and investigate options.
- Ensure that continuous cleaning sprays are not left running unnecessarily by installing sensors to switch off the water supply.
- Install controls on water flows to process equipment, to optimise water use.
- Install timers on hoses and taps that may be left on unnecessarily.
- Investigate whether level controls will help prevent spills.
- Install controls that automatically close valves to drain when a phase interface is detected, to reduce loss of water, product or chemical.
- Regularly check that all process controls are functioning properly and are correctly calibrated.

3.2.4 Leaks

It is important that leaking equipment such as pumps, valves and hoses are promptly repaired. Equipment that is left leaking over lengthy periods can waste significant amounts of water or product. Table 3.5 gives some examples of the cost of water losses. For large equipment items that use large quantities of water, the cost of installing and regularly monitoring meters to detect leaks can be well justified.

Table 3.5: Examples of water loss from leaking equipment

Equipment	Hourly loss (L)	Annual loss (kL)	Supply water cost (\$/year)	True water cost (\$/year)
Union/flange (1 drop per second)	0.5	5	6	12
Valve (0.1 L/min)	6	53	60	123
Pump shaft seal (0–4 L/min)	0–240	0–2 100	0–2 373	0–4 893
Ball valve (7–14 L/min)	420–840	3 680–7 360	4 158–8 317	8 574–17 149
1 inch hose (30–66 L/min)	1 800–4 000	15 770–34 690	17 741–39 200	36 744–91 336

Assumption: Purchase cost of water: \$1.13/kL; true cost of water: \$2.33/kL (refer to Section 3.1.2). Hourly and annual water loss figures from Envirowise: www.envirowise.gov.uk/envirowisev3.nsf/key/d0e2836?open&login



Eco-efficiency action

- Establish a system to report, record and fix leaks promptly.
- Install meters on equipment that use large quantities of water to help monitor water consumption and detect leaks promptly.
- Compare water use with the equipment design specifications.
- Ensure that the flow meters are calibrated appropriately.
- Review trends in consumption of water use and during periods of non-use.

3.2.5 Water-efficient processing operations

By modifying existing processing operations or investigating more water-efficient alternatives, it may be possible to reduce water use in the plant. For example, some vegetable processors use water to transport vegetable product that could possibly be conveyed mechanically or pneumatically. In other cases it may be possible to use steam instead of water for blanching.

Sometimes water use can be totally eliminated, using 'dry systems'. For example, peeling processors sometimes use a caustic bath to peel vegetables and fruits, briefly immersing them in the solution and then passing them under a heater. The peel, with residual caustic, is removed by a rubber disc peeler and pumped to a solid waste hopper, thereby preventing it from becoming part of the wastewater stream.

Counter-current rinsing is another means of reducing water in process operations. Clean water is introduced, flowing counter to the flow of food product, at the final rinse stage of a water bath. The used water is then reused as a first rinse for the incoming food.

Products are sometimes thawed or tempered (partially thawed) in open tubs of water; this consumes large quantities of water and produces high-strength effluent. Such products could possibly be thawed more efficiently using sprays, vacuum thawing, air blasting or still air. New developments in tempering using radio-frequency waves, for example, could lead to savings not only in water but also in space, energy and reduced drip loss. The product can often be tempered inside its packaging, as temperature distribution throughout the frozen mass is highly uniform. Radio-frequency tempering with its long wavelength is best suited for heating frozen blocks of seafood, fruit and vegetables from -20°C to around 0°C (Sairem 2003).

Case studies

Dry peeling versus wet peeling: vegetable processor, UK

A beetroot processor peels approximately 72 tonnes of beetroot per day. When wet and dry caustic peeling processes were compared, it was found that dry peeling reduced water use by 75%.¹

Water reuse for boiler feed and counter-current: citrus processor, Australia

Irymple Citrus Products in Victoria reduced its water consumption by 30% by recycling condensate water for boiler feed, counter-current rinsing and, where possible, recycling water from water sprays.²

Modification of thawing tubs to reduce water consumption: fish processor, Australia

Tony's Tuna International in South Australia had previously thawed its pilchards using cold-water open tanks with water running continuously. By moving the water inlet to the base of the thaw-out bins, and by pulsing water exchange via solenoid valves, water consumption was reduced from over 12 L per tonne to 3.4–5.6 L per tonne. The payback period for the new piping, solenoid valves and bin adaptations was less than 1 month.³

Replacement of defrosting tubs with water spray system: fish processor, UK

Richard Coulbeck Ltd previously ran water continuously through defrosting tubs. After introducing a new sprinkler system, water supply costs were reduced from A\$248 per day to A\$50 per day.⁴

New technology for tempering: confectionery processor, New Zealand

A recent trial conducted by Keam Holdem Associates and Food Process Engineering Pty Ltd showed that radio-frequency tempering could uniformly melt cocoa blocks inside a plastic liner and cardboard carton. A 60 kW generator used with a two-zone tunnel was able to achieve a throughput of 1500 kg/hour. This type of heating overcame the problems of conventional heating methods (long lead times) and microwave heating (only able to penetrate the cocoa blocks to a depth of a few millimetres).⁵

¹ Envirowise 2001

² Environment Australia 2002c

³ Environment Australia 2003d

⁴ Envirowise1999c

⁵ Keam Holdem Associates Ltd and Food Process Engineering Pty Ltd 2003



Eco-efficiency action

- Investigate the feasibility of replacing equipment with more water-efficient systems, or 'dry' systems that are also energy-efficient.
- Consider dry mechanical transport systems where possible instead of transport by water.
- Counter-current rinse wherever possible or store final rinse water in a holding tank for subsequent pre-rinsing.
- Consider changing to a thawing system that uses little or no water, such as sprays instead of baths, use of ambient air, air blasting, radio-frequency or microwave thawing.

7.3.3 Thermodynamic Processes

Overview

Thermodynamics is the term physicists use to describe energy transfers that can be strictly related to heat and work.¹⁵² Single-pass (once-through) cooling, cooling towers, evaporative coolers, and boilers are examples of water dependent thermodynamic processes technologies found throughout the CII sectors. Water is the key substance used by these technologies to affect heat and energy transfer and transformation. This section covers both heating and cooling systems that use water; non-water-dependant processes are not covered in this discussion.

The heating, ventilation and air conditioning (HVAC) industry is directly involved in providing heating, hot water, and cooling to the commercial and institutional sectors. The NAICS code for that industry is 238220. For industrial operations, cooling tower construction and installation can be classified under NAICS 333415 or 332313, while boilers can be classified under NAICS 238290 or 332400.

7.3.3.1 Cooling Systems

Overview – Cooling Systems

Cooling systems remove "unwanted" energy in the form of heat and dissipate that heat to the environment. Examples of cooling systems include air conditioning, process cooling, dehumidification, and refrigeration. Cooling is either achieved by evaporating water, by the direct use of water, or by the use of a mechanical refrigeration system. To begin this discussion, two terms are defined below.

Heat Pump

A heat pump is a machine or device that "moves" thermal energy from one location to another. In the case of refrigeration or air conditioning, heat pumps are used to cool a space; heat is moved from the "source," which is at a lower temperature, to location of higher heat, called the "heat sink." Mechanical air conditioners and refrigeration systems are heat pumps. If reversed, the heat pump moves heat from the outside to the inside to warm a space.

Heat Sink

A heat sink in this context is the environment – air, water, or earth – that holds the unwanted heat.

- **Air As a Heat Sink.** An example of air as a heat sink is the typical home air conditioner. The outside unit contains the compressor, cooling coils, and fan. The compressor pump compresses the working fluid, such as Freon™ gas, which becomes very hot from

¹⁵² "Work" is thermodynamically defined as the energy transferred from one system to another.

the energy put into it though the compression. A fan then cools the gas by drawing in outside air and forcing it over the coils, thus returning the working fluid to a liquid phase. The heat from the motor and the heat from liquefying the Freon™ is rejected to the atmosphere. The liquid then flows back inside air conditioning coils where it expands as it passes through a small valve. As it turns back into a gas, it becomes very cold, able to absorb the heat from the room being cooled as the inside air handler (fan) blows over the coils. The gas returns to the compressor, and the process repeats over and over again. The heat in the room is therefore pumped to the outside environment and discharged to the outside air (heat sink).

Air coolers for removing process heat provide another example. They work like car radiators: a fan draws outside air over coils as the warm fluid is pumped through the coils. The air acts as the "heat sink" to remove heat from (cool) the liquid in the tubes.

- **Earth as a Heat Sink.** Some air conditioning units use the ground as a heat sink. These "geothermal" units run coils into the earth and the earth absorbs the heat rejected¹⁵³ by the unit.
- **Water as a Heat Sink.** Water is passed over the coils or through a "heat exchanger" where the working fluid or material being cooled transfers that heat to the water. The water can also be used in direct contact with the air to cool it through evaporation; such as the case with an evaporative cooler, which is sometimes called a swamp cooler.

A variation of this system is the chilled water loop. Water is cooled mechanically and circulated through a building to cool air (air conditioning) or equipment, and then returned to the chiller unit.

- **Combined Heat Sinks.** Cooling towers represent a combined case where water is used to remove heat from a compressor or from a manufacturing process. The warmed water is then sent to a cooling tower where the waste heat is "rejected" to the atmosphere by evaporating that water.

Types of Processes – Cooling Systems

There are five basic types of cooling systems that rely on water:

- Single-pass cooling
- Once-through cooling on natural bodies of water
- Cooling reservoirs
- Evaporative cooling
- Cooling towers

¹⁵³ 'Heat rejection' refers to the process of heat disposal/dissipation to the heat sink.

Single-Pass Cooling

Single-pass cooling uses water to remove heat, thus cooling equipment components. Water passes through a coil within or casing around a piece of equipment, and is then discharged to the sewer.

For the purposes of this report, single-pass cooling refers to the use of water to cool commercial and industrial type equipment. Types of equipment that often use single-pass cooling include:

- Chillers or other refrigeration systems
- Condensers
- Air compressors
- Hydraulic equipment
- CAT scanners
- Degreasers
- Welding machines
- Vacuum pumps
- X-ray equipment
- Ice machines
- Wok stoves

Vacuum pumps, X-ray equipment, ice machines, and wok stoves use water for processes, in addition to the water used for single-pass cooling. Such equipment and its associated water use, apart from single-pass cooling, are discussed in other sections (e.g., Section 7.1.4.2 Medical and Laboratory Equipment and Processes, Vacuum Systems; Section 7.1.4 Medical and Laboratory Equipment and Processes, Photographic and X-Ray Equipment; Section 7.1.1.10 Commercial Food Service, Ice Machines; and, Section 7.1.1.10 Commercial Food Service, Wok Stove, respectively).

Once-through Cooling With Natural Bodies of Water and Cooling Reservoirs

Large industrial operations, including manufacturing facilities and power plants, sometimes use "once-through" cooling with water from a natural body of water.

Natural Bodies of Water

Once-through cooling with natural bodies of water refers to the use of a river, natural lake, or saltwater body as a source of cooling water. Water is directly returned to the natural body of water from which it was withdrawn. Since enormous volumes of water are typically involved, these withdrawals can affect aquatic wildlife by both entrapping them in the flow of water and by creating thermal barriers with the warm water that is discharged. To put this into perspective, one 750-megawatt power plant can withdraw as much as 1.5 billion gallons of water per day. For these reasons, the State of California no longer allows power plants to employ once-through cooling using sea water and freshwater sources that are not sufficient to support this type of flow rate. Smaller industrial facilities and some air conditioning systems can use this type of cooling, but permitting requires careful consideration. Because of its limitations, no further consideration is given in this document: once-through cooling is not recommended as a best management practice.

Cooling Reservoirs

Cooling reservoirs, sometimes called cooling ponds, are manmade reservoirs used by industries and power plants for process cooling. Water is pumped through heat exchangers and recirculated through the reservoir where it cools through natural processes. The amount of water evaporated from a cooling reservoir is a combination of natural evaporation and evaporation from the added heat from the cooling process ("forced evaporation").

Evaporative Cooling

One of the oldest technologies used to cool an occupied space is an evaporative cooling system, sometimes called a 'swamp cooler'. These coolers simply pump water over wet pads that have air drawn through them. The evaporation of the water cools the air passing through it. This air is then blown into the space to be cooled (refer to Figure 7.48 for an example evaporative cooler). These systems are inexpensive and use less energy than a refrigerated air system common to most residential and light commercial applications. However, they can consume significant volumes of water if not properly controlled.

Conventional Evaporative Cooling

Evaporative coolers can either be of the once-through-type or recirculating-type. In the once-through-type, water, usually from a potable water supply, is continuously run over the pads and allowed to drain either to the yard or to a storm or sanitary drain. These systems are very wasteful. Most modern evaporative coolers have recirculating pumps that continuously pump water from a basin over the pads when the system is on. They use a float valve similar to that in a toilet tank to maintain the water level in the basin. Water is "bled-off" to flush salts from the system either by a valve left partially open or with the use of a conductivity probe and solenoid valve system, as is the case in larger more sophisticated systems.



www.ose.state.nm.us/water.../conservation/evap-coolers-brochure.pdf

Figure 7.48 - Evaporative “Swamp” Cooler

Indirect Evaporative Cooling

Another technology uses a heat exchanger arrangement. Part of the air is humidified and thus cools. This cool air is then passed through a metal "heat exchanger." This device passes the humid cool air on one side of metal sheets and discharges the warmer, more humid air back to the atmosphere. On the other side, air from the occupied space is circulated where it contacts the cooler metal surfaces, where it absorbs heat from circulating air. The cooled air is returned to the living space and the humid, warmer air is exhausted to the outside. This system is called indirect evaporative cooling.

Pre-Cooling

In recent years, a new form of evaporative cooler has entered the market. It works by pre-cooling air that is being used to cool conventional air-cooled air conditioning coils. These systems are also used to pre-cool air for gas turbines and other industrial operations. These pre-cool systems use the same evaporative technology and have the same considerations as conventional evaporative coolers. The cool, humid air is then drawn through conventional air coils of an air conditioning system.

Cooling Towers

Common applications of cooling towers in the CII sectors are to remove heat (unwanted energy) generated by a manufacturing process and for air conditioning and refrigeration equipment. Warm water from process or cooling equipment is introduced at the top of a cooling tower and trickles over a packing material, such as plastic corrugated fill. The water breaks up into a film or droplets over the packing material to maximize surface area, which in turn maximizes evaporation. Water collected in the well at the bottom of the tower is recirculated through the

process. Recirculating water undergoes a temperature change of about 5°F to 15°F through this process. The water is usually cooled to within 10°F of the wet-bulb temperature.¹⁵⁴ Water circulating through the cooling tower loop is called the mass flow, and can vary from 100 to 200 gallons per ton-hour¹⁵⁵ depending on the change in temperature. The flow is just less than 150 gallons per ton hour for a 10°F change in water temperature as it's pumped through the heat exchanger.

There are two basic cooling tower configurations:

- Counter-flow towers draw air from the bottom while water is continuously sprayed onto the top of fill material in the tower.
- With cross-flow towers, air is drawn in from the side and across the fill, while water is sprayed from the top in a manner identical to counter-flow configurations. Fans can be located at either the outside or the bottom of the towers (forced-draft) or on top of the tower to draw the air out the top (induced-draft).

Figure 7.49 shows the general operation diagram for cooling towers and Figure 7.50 shows an actual cooling tower in operation.

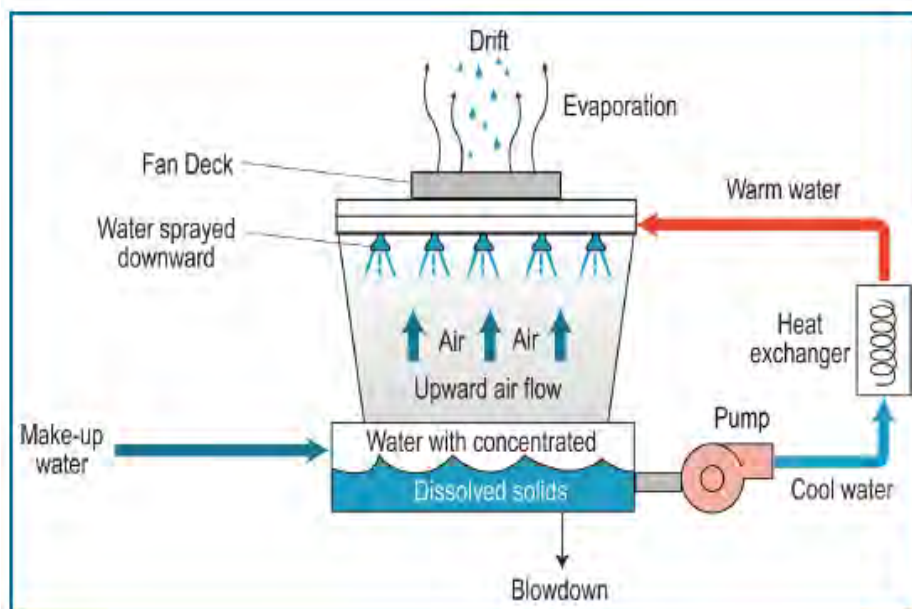

Source: US. Department of Energy, Federal Energy Management Program

Figure 7.49 - General Water Flow Diagram for a Cooling Tower

¹⁵⁴ The wet-bulb temperature measures how much water vapor the air can hold at current weather conditions.

¹⁵⁵ One ton-hour is equivalent to 12,000 BTUs by definition



Figure 7.50 - Marley Counter-Flow Towers

Cooling Tower Water Quality Considerations – *Cooling Systems*

Water quality is critical for cooling towers. The materials that the tower and heat exchanger equipment are made from, the quality of the makeup water, and the type of treatment provided determine the tower's safe cycles of concentration.¹⁵⁶ Factors to consider include:

- **Scaling** - the buildup of calcium, magnesium, or silica deposits on tower surfaces and more importantly, the heat exchanger surfaces. These deposits restrict flow and significantly reduce thermal efficiency. Calcium carbonate precipitates when concentrations are above 750 to 850 mg/l and silica can form a very hard scale on hot surfaces at concentrations as low as 120 mg/l.
- **Corrosion** - the oxidation of metals due to rusting and other forms of corrosion causes pitting, rusting, and deterioration of metal surfaces.
- **Biological fouling** - the growth of algae and bacteria causes fouling of heat exchanger surfaces and of cooling tower fill and basin material. It also promotes corrosion and deterioration of tower surfaces.

Towers also act as huge air scrubbers as they operate, capturing dirt, insects, and airborne debris.

As the conductivity increases (salt concentrations increase), metals are more susceptible to corrosion. The type of material that the tower and exchanger are made of determine this susceptibility. Many commercial operations operate towers at water conductivities of 3,500 microSiemens (μS) or less. The standards

¹⁵⁶ Cycles of concentration represents the accumulation of dissolved minerals in the recirculating cooling water; how many times the water can be reused before too much dissolved mineral build-up affects operations and efficiency. Draw-off (or blowdown) is used principally to control the buildup of these minerals.

for pretreatment established by various authorities represent other considerations, and include TDS limits and limits for metals, such as copper and zinc in the blowdown from the tower.

Managing the water chemistry of cooling tower water is not simple. Corrosion and scaling can easily damage both the cooling tower and the condenser equipment if not properly managed. Properly managing a continuously changing water chemistry that allows calcium carbonate and other minerals to deposit on metal surfaces, while also preventing metal corrosion, is a delicate balance. Various indices have been developed to help predict the corrosion/scaling balance points. These include the:

- Langelier Saturation Index
- Ryznar Stability Index
- Puckorius Scaling Index
- Larson-Skold Index
- Stiff-Davis Index
- Oddo-Tomson Index

Types of Water Quality Treatment

Over the years, many treatment methods have been developed to control water quality factors affecting cooling tower operation and efficiency. The type of treatment depends on the quality of the makeup water supplied to the tower and the desired cycles of concentration. The water can be treated (1) before it is fed to the cooling tower, (2) while the water is in the tower or piping system, or (3) by "side stream" systems that treat a portion of the circulating water in the tower.

The treatment of makeup water depends on the water chemistry and biology of the makeup water. The most common methods of treating makeup water before it is fed to the tower include:

- Filtration where particulates are an issue.
- Biocides such as chlorine if biological growth is an issue.
- Softening if hardness is an issue.
- Chemical treatment to remove precipitants and silica where applicable.
- Demineralization such as nanofiltration or reverse osmosis where TDS are an issue.

Treatment of makeup water before it enters the cooling tower can significantly simplify in-tower treatment and allow for the use of tower chemical and physical treatment devices that may not otherwise be effective. Treatment of recirculating cooling tower water depends on the type of problem.

Choosing the optimal treatment process or combination of processes requires an understanding of water chemistry and the process for which the water is being used. Entities with cooling towers are strongly encouraged to consult reputable cooling tower treatment experts.

Scale Control

For scale-forming substances, the following types of treatment to reduce or prevent deposition are common:

- Deposition inhibitors that prevent scale by solubilizing it, preventing precipitation or modifying precipitates to prevent adhesion.
- Dispersants that use polymers and large molecules to adsorb solids and keep them in suspension.

Examples of chemicals used for scale control include phosphonates to prevent scale formation, acids to increase solubility, chelates, and polymers. The use of acid should be carefully considered. Most commercial sites do not have properly trained staff to handle these dangerous chemicals. Where used, pH controllers are recommended to control the addition of acid. Special storage must also be provided.

Corrosion Control

Corrosion of metal components is a major concern. For concrete basins, many of the same conditions that cause metal corrosion can also cause the concrete to deteriorate. Phosphate-based compounds (ortho-phosphate, polyphosphate, and others) and similar chemicals are often used for steel surfaces. In the past, other metals ranging from chromates to zinc and molybdate compounds were used. Chromates were banned years ago, and zinc and molybdenum compounds are now phased out since these can cause environmental contamination and they can be toxic. For copper,azole compounds have been used.

Salinity and pH levels are also important. Some treatment techniques maintain pH levels in the range of 8.0 to 9.0 to help reduce corrosion. Conductivity controllers help by keeping salinity levels at acceptable levels for the tower's construction materials. Ceramic and plastic materials are often used because they are corrosion resistant.

Biological Control

Bacteria can cause slime growth on heat exchange and cooling tower surfaces, promote certain types of corrosion, and cause significant chemical imbalances. Algae grow wherever sunlight is present and can cause similar problems. Cooling towers are classic sources of pathogen growth, such as legionella. Common methods of biological control include chlorine and bromine compounds and ozone to control bacteria and algae in the water column. Even shading to keep sunlight from entering the tower can help limit algae growth. Many new methods

of cooling tower water treatment, such as the use of ultraviolet light disinfection, are now on the market.

General

Side-stream treatment of cooling tower water has been used for years and is effective for control of sediment, hardness, silica and other constituents that may affect water quality. Filtration, softening, chemical precipitation, and other methods are also available on the market.

Water Use Information – Cooling Systems

Single-Pass Cooling

The flow rate needed to cool the equipment depends on the amount of heat rejected by the equipment. Manufacturer specifications generally provide a flow rate. If not, the measured energy rejected by the equipment can be used to calculate flow rates.

Example: Manufacturer's Recommended Flow Rate

A piece of equipment has a recommended flow rate of 2.5 gallons per minute. How much water does it use in a day?

Equation 7.27

$Water\ use = flow\ rate\ (gpm) \times 1,440 = 2.5 \times 1,440 = 3,600\ gallons\ per\ day$

Evaporative Cooling

The effectiveness of this type of cooling depends on the relative humidity of the outside air and the outside temperature. Evaporative coolers only work well in relatively dry climates. Under perfect conditions, the amount of water that must be evaporated to provide one ton of air conditioning is 1.48 gallons/hour, based on the latent heat of water of 970 BTUs per pound of water evaporated. Water is also needed to flush out dissolved solids from the supply water so these salts do not build up and precipitate out on the pads and in the cooler basin. Current models can use between 3 to 15 gallons/hour of water per ton-hour according to the Alliance for Water Efficiency.

Cooling Tower

The amount of water a cooling tower uses depends on two main factors:

- The amount of heat discharged to the tower.
- The cycles of concentration.

The amount of water used by a cooling tower (makeup water) primarily depends on the amount of heat dissipated by evaporation, the amount that must be discharged to prevent the buildup of dissolved minerals and salts (blowdown). The amount of water lost through drift, leaks, overflows, and other losses can

also affect the amount of makeup water required. This can be expressed in a simple equation (Equation 7.28).

Equation 7.28

$$M = E + B + D + L$$

Where M = Makeup, E = Evaporation, B = Blowdown,
 D = Drift and wind loss and L = Leaks, overflows, and other losses

Evaporation and Blowdown

Heat drives evaporation. Table 7.39 estimates the evaporation that will occur per ton-hour of heat rejected. When the amount of heat rejected to the tower (BTUs) is known, the process row in Table 7.39 should be used to estimate evaporation.

When the chilled water system's efficiency is maximized, the total heat load to the tower will be lower and will successively lower the evaporation per ton-hour of actual heat removed in the refrigeration process. When a chilled-water cooling system (chiller) works, it pumps heat from the building, including the heat generated by the cooling system, to the cooling tower. It takes energy to pump the water in both the chilled water and cooling tower loops in order to operate the air handling units in the buildings and the compressor. A compressor may be rated at 0.5 kilowatt-hours per ton-hour, but when all of the other pump and air handling unit energy is added, an additional 0.1 to 0.15 kWh of energy is typically needed per ton-hour.

Table 7.39 shows the effect of this additional energy on the amount of water evaporated per ton-hour of actual cooling achieved for comfort inside a building. The higher the energy efficiency ratio of the system, the less water it needs. Compressor efficiency has improved significantly over the last few decades. Compressors with an efficiency rating of 0.5 kWh/ton-hour or less are available, but even with these very efficient systems, total loads per ton-hour of actual cooling will be in the 0.6 to 0.7 kWh/ton-hour range. Most total system energy efficiencies are currently under 1.0 kWh per-ton hour, even for less efficient systems. Nonetheless, the amount of water evaporated per ton-hour of actual cooling in a building can range from 1.67 gallons per ton hour to 1.86 gallons per ton-hour of total chiller system operation.

Table 7.39 - Impact of Air Conditioning System Efficiency on Water Evaporation

System Efficiency <i>(kWh / ton-hr.)*</i>	Energy Efficiency Ratio (EER) <i>BTU's/ Watt-hr</i>	Coefficient of Performance (COP) <i>BTU's Removed/ BTU's Input</i>	BTU's Rejected to Tower per hr	Gallons Evaporated per Ton Hour
1.50	8	2.3	16,608	2.05
1.00	12	3.5	15,072	1.86
0.75	16	4.7	14,304	1.76
0.50	24	7.0	13,536	1.67
Process	N/A	N/A	12,000	1.48
One ton-hour = 12,000 BTU's per hour = 12.66 Million Joules per hour = 3.52 kWh of heat energy to the tower.				
* kWh / Ton-hr. is often abbreviated to kW/Ton				

The gallons evaporated per ton-hour of cooling multiplied by the hours of operation will equal the actual amount of water that will be evaporated. This will provide the "E" in Equation 7.36, $[M = E + (M \div CC)]$.

When warm water from a process or an air conditioning compressor is returned to a cooling tower, its energy is dissipated to the atmosphere primarily by evaporation. The heat removed by evaporating one pound of water is approximately 970 BTUs and is known as the latent heat of evaporation. One gallon of water weighs 8.34 pounds, so the evaporation of one gallon removes 8,114.8 BTUs. One ton-hour of cooling is equal to 12,000 BTU's by definition. Therefore, 1.48 gallons of water is evaporated for every ton-hour rejected to the cooling tower.

As water evaporates, the dissolved minerals and salts in the makeup water remain. Additional water must be added (makeup) and some of the water in the basin periodically discharged (blowdown) to prevent minerals from building up and causing scaling and corrosion.

Drift and Wind Losses

Another type of water loss derives from drift and wind. It is caused by the entrainment of small droplets of water in the air stream as the fans force air through the tower or from wind blowing through the tower. If no drift eliminators are used, drift loss could be as high as 0.3 percent of circulation

Modern towers are equipped with very effective drift eliminators. Drift losses can be reduced to under 0.003 percent of the mass flow of the tower as reported by many manufactures. For a typical cooling tower, mass flow is in the range of 150 gallons per hour per ton-hour of cooling. With a modern drift elimination system, drift loss would be in the order of only 0.004 gallons per ton hour or under 0.3 percent of evaporation. This makes drift loss almost negligible. Drift eliminators also significantly reduce aerosols containing bacteria such as *Legionella* (causes Legionnaire's Disease), as well as particulate deposition and salt deposits. The

implication of this is that drift term (D) in Equation 7.29 can be dropped as part of the calculation.

Leaks and Other Losses

Leaks and other losses are primarily a maintenance issue. Well-maintained systems have little or no leak loss.

One common source of loss is an improperly set water level in the basin of the cooling tower. Water levels can be maintained with a float valve (see Figure 7.51) or ultrasonic level control valve (see Figure 7.52).



Figure 7.51 - Cooling Tower Float Valve and Overflow Pipe

Properly maintaining the float or level controller, eliminating leaks, and installing modern drift eliminators, simplifies Equation 7.28 to Equation 7.29:

Equation 7.29

$$M = E + B$$

Cycles of Concentration

The next step in estimating water use for a cooling tower is to determine the cycles of concentration. The concentration of the minerals (salinity) in the blowdown divided by the concentration of the minerals in the makeup water is called the cycle of concentration (CC). This concentration of minerals is often called "total dissolved solids (TDS)" and is reported in milligrams per liter (mg/l) or parts per million (ppm).

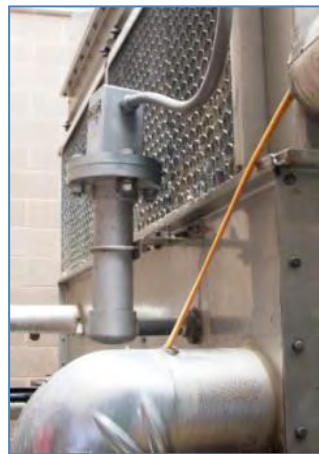

Figure 7.52 - Ultrasonic Cooling Tower Level Control Valve

Figure 7.53 shows the effect of increasing the CC on the total makeup water needed per ton-hour of actual heat removal based on system efficiency. Figure 7.53 makes two major points: first, energy efficiency saves water; second, after achieving six to ten CC, additional water savings are minimal. Figure 7.54 shows the diminishing water savings potential more dramatically. Going from 10 to 20 cycles of concentration only saves 0.10 gallons, while going two to five cycles of concentration saves 1.3 gallons of makeup water.

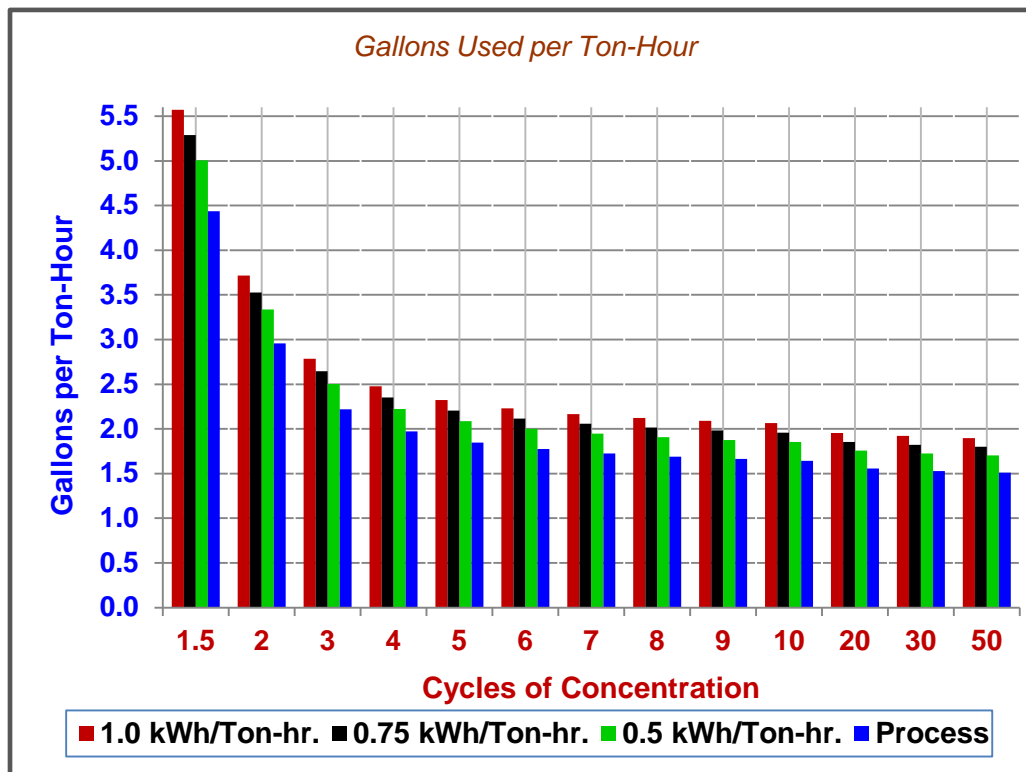

Figure 7.53 - Cooling Tower Makeup Requirements

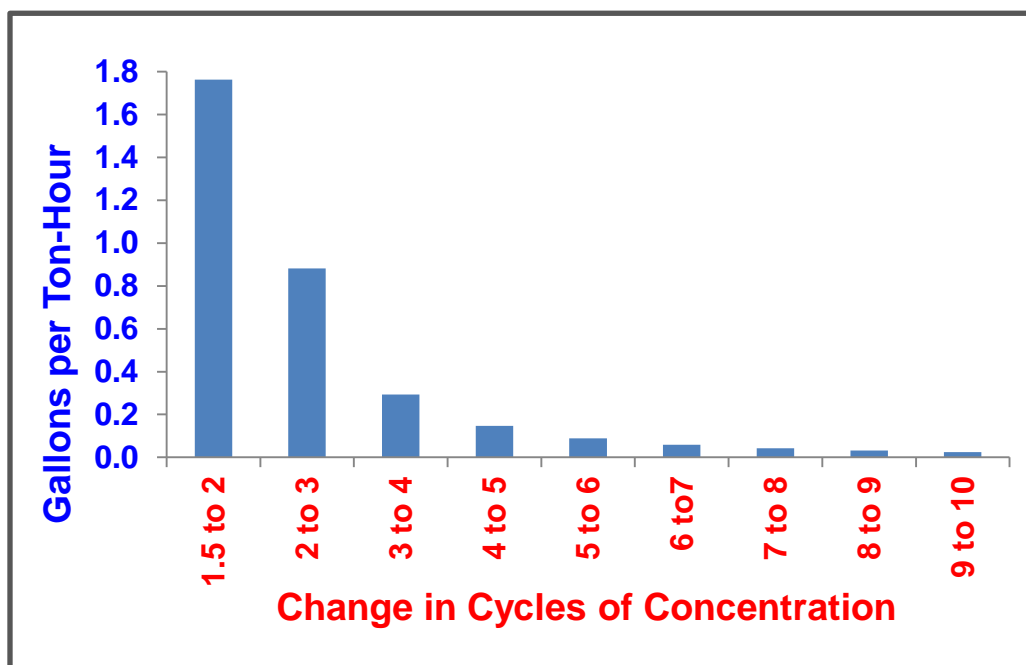

Figure 7.54 - Water Savings Potential

Since the electrical conductivity of the water is related to the TDS, conductivity can be used to estimate TDS. Conductivity is measured in microSiemens (μ S). If

the conductivity of the makeup water is 100 μS and the conductivity of the blowdown is 500 μS , the tower would be operating at five CC.¹⁵⁷

Equations 7.30 and 7.31 show the calculation of CC.

Equation 7.30

$$\text{Cycles of Concentration (CC)} = \frac{\text{Total Dissolved Solids (TDS) in Blowdown}}{\div \text{TDS in Makeup Water}}$$

$$CC = \frac{\text{TDS (blowdown water)}}{\div \text{TDS (makeup water)}}$$

Where conductivity is used in place of TDS, as it is for all cooling tower controllers, the following equivalent equation should provide the same results.

Equation 7.31

$$CC = \frac{\mu\text{S (blowdown water)}}{\div \mu\text{S (makeup water)}}$$

Conductivity can be used as an approximate substitute

If leaks, overflows, and drift are negligible, Equation 7.29 can be rearranged to provide an estimate of cycles of concentration:

Equation 7.32

$$CC = M/B$$

and therefore:

Equation 7.33

$$B = M \div CC$$

Equation 7.34

$$M = E + (M \div CC)$$

Equation 7.32 is an important check to determine tower efficiency. If the results of Equation 7.32 vary from the results of either Equations 7.30 or 7.31 by more than five percent, something is wrong. Either the conductivity probe or meter are not calibrated correctly, or there is a leak or failed drift eliminator. As cycles of concentration increase, the amount of makeup needed and thus the amount of water used by a cooling tower decreases, but only to a point.

¹⁵⁷ $CC = 500 \mu\text{S} / 100 \mu\text{S} = 5$

General BMP Options – Cooling Systems

BMP for cooling systems occurs at several levels. Discussion of the technology and technical feasibility of energy efficiency measures and their cost is beyond the scope of this document.

Reducing Energy Input

The purpose of a cooling system is to get rid of unwanted energy. Any action that can reduce the amount of energy to be eliminated will reduce heat rejected to a cooling system. Where water is used as the cooling medium, these actions will reduce water use. Ways to reduce the load on a water-based cooling system, and therefore save water, include:

- **Energy Conservation.** Evaluate the processes in the plant for maximum energy efficiency and waste-heat recovery, since a more efficient building will reject less heat to the cooling tower.
- Energy conservation reduces the amount of waste heat generated and thus the cooling load regardless of the type of cooling system used. For example, for every ton-hour of energy savings for an air conditioning system using a cooling tower, 1.48 less gallons of water are evaporated, and at five cycles of concentration, about 2.25 gallons of makeup water are saved. Recovery of energy for water or space heating, operation of a desiccant drying operation as part of a desiccant cooling system, and preheating of material in an industrial operation are all examples of this strategy.
- **Use Non-Water Based Equipment/Processes.** Replacing processes or equipment with systems that do not require water cooling is the most obvious and one of the best ways to eliminate water use and save energy. Waste or unwanted energy can be discharged to the air, ground, or water. Where feasible, use cooling systems that reject waste heat (unwanted energy) directly to the atmosphere or to the ground.

Water Cooled System BMPs

If air-cooled or ground-cooled systems are not used, and cooling with water is the only option, it is important to choose the correct system.

Single-Pass Systems

- The BMP for single-pass systems should be elimination of this process. The only possible exceptions should be for medical emergencies.
- Where single-pass systems must be used, cool with non-potable water where feasible.
- Single-pass systems can also be connected to a chilled water or cooling tower loop, or a standalone reticulating refrigeration system

may be used. Recirculating refrigeration systems (Figure 7.55) are commonly found in laboratory and medical settings.

These systems typically use 0.5 to 1.0 kWh per hour of energy. Water use, based on actual audit data for such uses, averages 1.0 to 3.0 gallons per minute or 60 to 180 gallons per hour. Based on combined water and sewer rates for the six largest cities in California for 2010, water costs an average of \$7.77 per thousand gallons. Thus, the value of the water saved by installing a chiller system ranges from \$.47 to \$1.40, while cost of the electricity to operate the system equals only \$.05 to \$.15.

Evaporative Coolers

The USEPA's 2009 WaterSense® Single-Family New Home Specification sets specific standards for evaporative coolers. WaterSense® recommendations are as follows:

Evaporative cooling systems – Evaporative cooling systems shall:

- Use up to a maximum of 3.5 gallons (13.3 liters) of water per ton-hour of cooling when adjusted to maximum water use.
- Blowdown shall be based on time of operation, not to exceed three times in a 24-hour period of operating (every eight hours).
- Blowdown shall be mediated by conductivity or basin water temperature-based controllers.
- Once-through or single-pass cooling systems, systems with continuous blowdown/bleedoff, and systems with timer-only mediated blowdown management shall not be used.

In addition to the WaterSense® BMPs, for large systems of more than 50,000 cubic feet of air per minute, it is recommended that the systems be equipped with the following:

- Makeup meter on water supply.
- Overflow alarms for water level in the basin.

Automatic water and power shutoff systems for freezing.

Alternate Sources of Water

- The use of alternate sources of water, especially for cooling towers and cooling reservoirs, is one of the most effective ways to reduce the use of potable water in CII operations. Section 9 Municipal Recycled Water and Section 7.3.1 Alternate Onsite Sources of Water describe how these freshwater sources can be used in place of



Figure 7.55 - Recirculating Refrigeration System in a Chemistry Laboratory

potable water. In all cases, it must be remembered that freshwater sources should also be used efficiently.

- Air conditioning condensate is of specific interest since it is produced as part of the air conditioning process.

Operation, Maintenance, and User Education BMPs

– Cooling Systems: Cooling Towers

Operational Considerations

Operational processes are the first consideration in the efficient operation of a tower.

- For towers larger than 500 tons, a continuous electrical record of operations should be available for downloading. If that record is not available, the operator should maintain a written shift log. A logbook also provides a written shift log. At a minimum, the shift log should contain:
 - Details of makeup and blowdown quantities, conductivity, and cycles of concentration
 - Chiller water and cooling tower water inlet and outlet temperatures
 - A checklist of basin levels, valve leaks, and appearance
 - A description of potential problems
- Above all, ensure that the employee responsible for the cooling tower operations is knowledgeable of what to look for when examining records and what to look for when visually examining the cooling tower.
- Operate towers at a minimum of five CCs using potable water, depending upon the chemistry of the makeup water used. In certain cases, where source water quality is high, CCs of as much as 15 may be achieved.
- Provide adequate training to cooling-tower operators and maintenance personnel.
- Perform a life cycle cost analysis, including all operating, capital, and maintenance costs, to determine the cost effectiveness of a cooling tower vs. air cooling.

Water Treatment Vendor Considerations

- Choose a water treatment vendor that will work with your facility.
 - Select a water treatment vendor that focuses on water efficiency. Request an estimate of the quantities and costs of treatment chemicals, volumes of makeup and blowdown

water expected per year, and the expected cycles of concentration that the vendor plans to achieve. Specify operational parameters such as cycles of concentration in the contract. Increasing cycles from three to six reduces cooling tower makeup water by 20 percent and cooling tower blowdown by 50 percent.

- Work with the water treatment vendor to ensure that clear and understandable reports are transmitted to management in a timely manner. Critical water chemistry parameters that require review and control include: pH, alkalinity, conductivity, hardness, microbial growth, biocide, and corrosion inhibitor levels.

Design and Retrofit BMP Options – Cooling Systems: Cooling Towers

- Install a conductivity controller that can continuously measure the conductivity of the cooling tower water and that will initiate blowdown only when the conductivity set point is exceeded. Working with the water treatment vendor, determine the maximum cycles of concentration that the cooling tower can sustain, then identify and program the conductivity controller to the associated conductivity set point, typically measured in microSiemens per centimeter ($\mu\text{S}/\text{cm}$) necessary to achieve that number of cycles. Conductivity controller systems cost from \$3,500 to \$100,000 depending on the nature of the facility in which it is installed. Possible savings possible depend on the increase in cycles of concentration.
- Install flow meters on makeup and blowdown lines. On most cooling towers, meters can be installed at a cost of between \$1,000 and \$50,000. Manually read meters can be used for smaller towers, but if the tower is 500 tons or more, meter readings should be automated and connected to an electronic data management system.
- Install automated chemical feed systems on large cooling tower systems of 100 tons or more. The automated feed will monitor conductivity, control blowdown, and add chemicals based on makeup

World's Largest GHP System

U.S. Department of Energy (DOE)

Office of Geothermal Technologies

Geothermal Heat Pumps (GHPs) for
Medium and Large Buildings

The Galt House East Hotel and Waterfront Office Buildings in Louisville, Kentucky, use a 4,700-ton GHP system to meet the heating and cooling needs of the complex. Completed in 1984, the 750,000-square-foot (70,000 m²) hotel uses a 1,700-ton GHP system that cost \$1,500 per ton to install. In comparison, a conventional system would have cost between \$2,000 and \$3,000 per ton. As a bonus, the system saves about \$25,000 per month in reduced energy costs and frees up about 25,000 square feet (2,323 m²) of additional commercial space that would have been needed to house conventional HVAC equipment. The Waterfront Office Buildings, built in 1994, add about 960,000 square feet (89,000 m²) of office space and almost 3,000 tons of GHP capacity to the project, making it the world's largest commercial GHP project. According to Marion Pinckley, Galt House designer and construction manager,

water flow. These systems minimize water and chemical use while protecting against scale, corrosion, and biological growth.

- Install overflow alarms on cooling tower overflow lines, and connect the overflow alarm to the central location so that an operator can determine if overflows are occurring. This alarm can be as simple as a flashing light in the control area. More sophisticated systems may include a computer alert.
- Consider contacting the water service provider to determine if the facility can receive a sanitary sewer charge deduction from the potable water lost to evaporation. If the utility agrees to provide this deduction, calculate the difference between the city-supplied potable water makeup and the blowdown water that is discharged to the sanitary sewer.
- Use high-efficiency drift eliminators that reduce drift loss to less than 0.002 percent of circulating water volume for cross-flow towers and 0.001 percent for counter-flow towers.

Replacement BMP Options – *Cooling Systems: Cooling Towers*

Direct Expansion Air Conditioning

Cooling towers can be replaced with direct expansion (DX) air conditioning, which is technologically similar to home air conditioning, and is the most common type of system used worldwide. The DX systems cost less than chilled water-cooling tower systems per ton, but they are limited in size and have lower energy efficiency. A commercial example of the use of DX systems would be for a large department store. Multiple units would most likely be mounted on the roof. Because there are multiple units, only the units needed to achieve comfort in the building would be operated, so the units that are operating would be working at their optimal operational level. If one unit needs repair, the other units can continue to operate.

With large cooling tower systems, either expensive excess capacity must be installed or the facility must take the risk of being without adequate cooling if one chiller or tower must be taken out of service.

Geothermal Heat Exchange

Replace water heat sinks with ground source heat exchanges. Ground source heat exchange, often called geothermal heat exchange, is a rapidly growing segment of the air conditioning and heat pump market. According to the U.S. Energy Information Administration, sales tripled between 2004 and 2009. The ground can absorb significant amounts of thermal energy (hot or cold). In addition, summertime ground temperatures are always below daytime air temperatures. In California, average ground temperatures increase from below 60°F in the north to the mid 70°F range in the south. Ground source heat pumps are being used for a multitude of commercial operations ranging from schools to hospitals. These

systems offer energy efficiencies similar to cooling towers in many cases, but they do not have the maintenance and liability issues associated with cooling towers. These systems can be operated in reverse in the winter for heating, thus eliminating the need for a dual cooling tower and boiler system. For office, school, and similar commercial operations, ground source heat exchange offers both convenience and energy savings with no evaporative water use.

Refrigerant Systems

Replace inefficient systems with refrigerant cooled systems. In recent years, variable refrigerant volume systems have come on the market. These systems use a working fluid such as Freon in place of the chilled water loop. They can be air cooled, ground cooled or water cooled, and they offer larger capacity and more application in commercial settings. The whole system is more efficient than older DX systems but less efficient than systems with cooling towers. These systems can also be used with ground source heat exchange systems making their energy efficiency levels similar to that of cooling tower systems without the use of water.

7.3.3.2 Heating Systems: Boilers

Overview – Heating Systems: Boilers

The term boiler can mean several things in the CII setting. Large water heating systems that do not "boil" water but simply heat it are often called boilers even though no steam is produced: these are not the focus of this discussion. The focus of this section is on steam-producing boilers.

Steam boilers are used in large building heating systems for cooking, operating steam turbines, or industrial heating operations. There are two main boiler configurations:

- The most common type is the fire-tube boiler, where the water tubes pass through the water being heated. Heat from the fuel's combustion passes through the tubes and turns the surrounding water to steam (see Figure 7.56).¹⁵⁸ Waste heat boilers are most often of the fire tube type in smaller operations.
- Another common type is the water-tube boiler. Water tube boilers are found in very large operations such as power plants. In these facilities, the water is contained in tubes that line a combustion chamber where gas, oil, or coal is burned.

The basic water conservation considerations for these two types of boilers are the same.

¹⁵⁸ New Mexico Office of the State Engineer. 1999. *A Water Conservation Guide for Commercial, Institutional and Industrial Users*. Page 68.

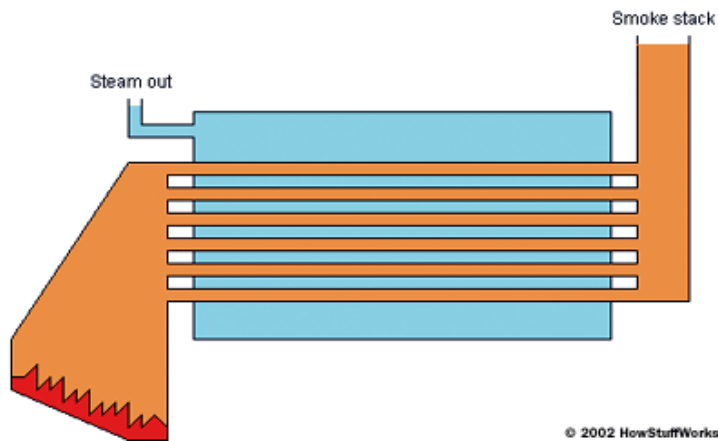

Figure 7.56 - Steam Boiler

Water Use Information – Heating Systems

To understand how to maximize water efficiency for a steam boiler, it is first necessary to understand how water is used in a typical boiler operation. Eight separate water uses and losses are typically associated with a steam boiler. These include:

- Makeup water to deaerator - Fresh water makeup to boilers is heated in a "deaerator" to remove air that can cause corrosion prior to feed into boiler.
- Condensate return to deaerator or boiler - Condensed steam that is returned to the boiler.
- Condensate loss - Condensed steam that is not returned to the boiler.
- Steam loss - Steam that is lost through leaks and other avoidable losses.
- Boiler water blowdown - Water from just below the top of the water level in the boiler that is discharged to control the buildup of dissolved minerals in the boiler.
- Flash-tank cooling water (tempering water) - When the boiler water is discharged, it must be cooled to under 140°F before it can be sent to a sanitary sewer. Once-through cooling is often used for this purpose.
- Sampler cooling water - The boiler blowdown must be cooled so it will not damage the conductivity controller probes. Single-pass cooling is often used for this.
- Mud blowdown - Sediments that collect at the bottom of the boiler need to be periodically purged by opening a valve at the bottom of the boiler. The frequency of this operation depends on the rate at which these sediments collect.

The water balance for the actual boiler can be written as a simple mass balance:

Equation 7.35

$$M = BD + CL + L$$

Where M = Freshwater Makeup, BD = Blowdown,
 CL = Condensate Loss, and L = All other losses

Equation 7.35 does not address the water used to cool blowdown or to cool the sampler. These factors must be considered separately. As with cooling towers, the ratio of the minerals in the makeup water to the boiler water is used to determine the cycles of concentration (CC). It can be expressed as:

Equation 7.36

$$CC = \frac{\text{Total Dissolved Solids (TDS) in Blowdown}}{\text{TDS in Makeup Water}}$$

Where conductivity is used in place of TDS, as it is for all cooling tower controllers, the following equivalent equation should provide the same results.

Equation 7.37

Conductivity can be used as an approximate substitute

$$CC = \frac{\mu S (\text{blowdown water})}{\mu S (\text{makeup water})}$$

If leaks and other losses are negligible, Equation 7.35 can be rearranged to provide an estimate of CC:

Equation 7.38

$$M = BD + CL$$

In most cases, some condensate loss is inevitable. This loss is typically expressed as a percent of actual makeup to the boiler that is supplied by steam condensate. The calculation this effect requires that the pounds of steam produced be known. The facility may wish to consult an engineer to help with these calculations. In many cases, condensate loss is known. In those situations, the CC provides the percent of blowdown.

**Operation, Maintenance, and User Education BMPs
 – Heating Systems**

To improve water efficiency of boiler and steam systems, consider the following:

- Choose a water treatment vendor
 - Select a water treatment vendor that that focuses on water efficiency.
 - Request an estimate of the quantities and costs of treatment chemicals and the volumes of makeup and blowdown water

expected per year. Choose a vendor that can minimize water use, chemical use, and cost while maintaining appropriate water chemistry for efficient scale and corrosion control.

- Read water chemistry reports
 - Ensure the water treatment vendor produces a report every time he or she evaluates the water chemistry in the boiler. Upon receiving these reports, read them to ensure that monitoring characteristics such as conductivity and cycles of concentration are within the target range. Problems within the system can be identified quickly if proper attention is paid to the water chemistry reports.
- Maintain boilers, steam lines, and steam traps
 - Regularly check steam lines for leaks and make repairs promptly.
 - Regularly clean and inspect boiler water and fire tubes.
 - Develop and implement an annual boiler tune-up program.
 - Provide proper insulation on piping and the central storage tank to conserve heat.
 - Implement a steam trap inspection program for boiler systems with condensate recovery. When steam traps exceed condensate temperature, this program can indicate that the trap is leaking. Temperature can be monitored using an infrared temperature device.¹⁵⁹ Repair leaking traps as soon as possible.
 - Minimize blowdown
 - Calculate and understand the boiler's cycles of concentration. Check the ratio of conductivity of blowdown water and the makeup water. (Use a handheld conductivity meter if the boiler is not equipped with permanent meters.) This ratio should match the target cycles of concentration.
- Work with the water treatment vendor to prevent scaling and corrosion and to optimize cycles of concentration.
- Improve makeup water quality:
 - Consider pre-treating boiler makeup water to remove impurities, which can increase the cycles of concentration the boiler can achieve. Water softeners, reverse osmosis systems, or demineralization are potential pre-treatment technology options.

¹⁵⁹ North Carolina Department of Environment and Natural Resources. May 2009. *Water Efficiency Manual for Commercial, Industrial and Institutional Facilities*. Pages 49-52.

- Boiler water must be treated before use for all but the very low pressure-type boilers. Table 7.39 summarizes recommended boiler water concentrations from the ABMA.

Table 7.39 - ABMA Standard Boiler Water Concentrations for Minimizing Carryover

Drum Pressure (psig)	Boiler Water		
	Total Silica* (ppm SiO ₂)	Specific** Alkalinity (ppm CaCO ₃)	Conductance (micromhos/cm)
0-300	150	700	7000
301-450	90	600	6000
451-600	40	500	5000
601-750	30	400	4000
751-900	20	300	3000
901-1000	8	200	2000
1001-1500	2	0	150
1501-2000	1	0	100

Retrofit and Replacement BMP Options – Heating Systems

BMPs for boilers comprise of two main components. The first is reducing water through energy and water use efficiency, including: minimization of system water losses, controlling cycles of concentration, and using condensate return. The second involves water efficiency with blowdown and sampler tempering water.

Energy Efficiency

Energy efficiency is the first BMP for consideration. Since heat is used to provide energy, any reduction in energy use will reduce water use.

- For maximizing boiler water efficiency, energy and water conservation for equipment, appliances, and fixtures that use hot water is the first major component to reducing hot water use.
- Install recirculating hot-water systems for large buildings.

Minimizing System Losses

Fixing leaks and reducing other losses is the second most important factor. With the exception of hot water used for space heating and equipment heat transfer, most hot water is consumptively used and not returned to the boiler.

- Where a recirculating loop is used for space or equipment heating, it is also important to meter the makeup line to determine if that line is leaking.
- Install code-compliant steam-distribution lines and equipment with steam traps.
- Ensure that discharge pipes are easy to inspect for flow. Provide visible indicators that will show whether the valve has activated, thereby reducing plumbing leaks due to repeated openings of water-temperature- and pressure-relief valves (TPRVs).

Maximize Cycles of Concentration

Significant water savings can result from improving the boiler system management scheme. A key mechanism to reducing water use is to maximize the cycles of concentration.

- Installing an automatic blowdown control system is one way to minimize blowdown and maximize cycles of concentration.
- Proper control of boiler blowdown water is also critical to ensure efficient boiler operation and minimize makeup water use. Insufficient blowdown can lead to scaling and corrosion, while excessive blowdown wastes water, energy, and chemicals. The optimum blowdown rate is influenced by several factors, including boiler type, operating pressure, water treatment, and quality of makeup water. Generally, blowdown rates range from four to eight percent of the makeup water flow rate, although they can be as high as 10 percent if the makeup water is of poor quality with high concentrations of solids.¹⁶⁰
- Operate closed-loop steam systems at twenty cycles of concentration or greater (5 percent or less of makeup water).

Maximize Condensate Return

From a water-efficiency standpoint, installing and maintaining a condensate recovery system to capture and return condensate to the boiler for reuse is the most effective way to reduce water use.

¹⁶⁰ U.S. Department of Energy. 2001. "Minimize Boiler Blowdown." www1.eere.energy.gov/industry/bestpractices/pdfs/steam9_blowdown.pdf, and U.S. Department Energy. 2001. "Return Condensate to the Boiler." www1.eere.energy.gov/industry/bestpractices/pdfs/steam8_boiler.pdf.

- Reduces the amount of makeup water required.
- Eliminates or significantly reduces the need to add tempering water to cool condensate before discharge.
- Reduces the frequency of blowdown, as the steam condensate is highly pure and adds little to no additional TDS to the boiler water.
- Since the steam condensate is relatively hot when it is added back to the boiler, less energy is needed to re-produce steam.

Metering, Measurement, and Control

Metering, measurement, and control are critical to good boiler operations and to minimizing water use. The following are BMPs recommended for boilers:

- Install an automatic blowdown control system, particularly on boilers greater than 200 horsepower, to control the amount and frequency of blowdown rather than relying on continuous blowdown.¹⁶¹ Control systems with a conductivity controller will initiate blowdown only when the TDS concentrations in the boiler have built up to a certain concentration.
- Install a flow meter on makeup water line to monitor the amount of makeup water added to the boiler. Install makeup meters on feed-water lines (Refer to Section 7.3.2 Building Meters, Submeters, and Management Systems for recommendations on how to use the meter once it is installed.)
 - To steam boilers and water boilers of more than 100,000 BTUs per hour.
 - To closed-loop hot-water systems for heating.
- Install condensate return meters for all boilers of 200 horsepower or more in closed loop systems.
- Install automated chemical feed systems to monitor conductivity, control blowdown, and add chemicals based on makeup water flow. These systems minimize water and chemical use while protecting against scale and corrosion. Equip steam boilers of 200 boiler horsepower (hp) or greater with conductivity controllers to regulate top blowdown.

Ensure that boiler-temperature and makeup meters are clearly visible to operators.

¹⁶¹ East Bay Municipal Utility District. 2008. *WaterSmart Guidebook—A Water-Use Efficiency Plan Review Guide for New Businesses*. Pages PHOTO1-PHOTO8.

Tempering of Sampler and Blowdown Water

Conductivity Probe Cooling Water

To properly control blowdown, the conductivity of the water in the boiler should be measured with a conductivity probe, bearing in mind that the boiler water is very hot and can damage the probe. Use a sampler cooler to cool the water to a temperature that is suitable for the probe. These simple devices simply pass water through a heat exchanger that takes a small side stream of boiler water from the boiler either on a continuous or intermittent basis (Figure 7.57). Most samplers are simple single-pass cooling systems. Flow rates in the literature range from 1.0 to 2.5 gpm. This capture and reuse of sampler cooling water as boiler feed water may require constructing a collection tank to hold the cooling water until the system needs to send makeup water to the deaerator tank.



Figure 7.57 - Boiler Water Sampler Device

Blowdown Tempering Water

Blowdown tempering water is water used to cool the water discharged from the boiler to control dissolved solids buildup. For smaller boilers, it is the author's experience that large holding tanks that allow the blowdown to cool to below 140°F may be used. For larger systems, heat recovery systems are commercially available that capture the heat and thus eliminate the single-pass cooling entirely.

Saving Potential – Heating Systems

Switching to an automatic control system can reduce a boiler's energy use by two to five percent and reduce blowdown by as much as 20 percent. A system can cost between \$2,500 and \$100,000. In some facilities, the water and energy savings can provide Payback within one to three years.

Both sampler and blowdown heat recovery systems save water and energy. The following example is from the U.S. Department of Energy's Energy Efficiency and Energy Renewable publication entitled Recovery Heat from Boiler Blowdown - www.eere.energy.gov:

Energy Savings Example: Heating Systems

In a plant where the fuel cost is \$8.00 per million Btu (\$8.00/MMBtu), a continuous blowdown rate of 3,200 pounds per hour (lb/hr) is maintained to avoid the buildup of high concentrations of dissolved solids. What are the annual savings if a makeup water heat exchanger is installed that recovers 90 percent of the blowdown energy losses? The 80 percent efficient boiler produces 50,000 pounds per hour (lb/hr) of 150-pounds per-square-inch-gauge (psig) steam. It operates for 8,000 hours per year. The blowdown ratio is:

Equation 7.39

$$\text{Blowdown Ratio} = 3,200 / (3,200 + 50,000) = 6.0\%$$

From the table, the heat recoverable corresponding to a six percent blowdown ratio with a 150-psig boiler operating pressure is 1.7 MMBtu/hr. Since the table is based on a steam production rate of 100,000 lb/hr, the annual savings for this plant are:

Equation 7.40

$$\text{Annual Energy Savings} = [1.7 \text{ MMBtu/hr} \times (50,000 \text{ lb/hr}/100,000 \text{ lb/hr}) \times 8,000 \text{ hr/yr}]/0.80 = 8,500 \text{ MMBtu}$$

$$\text{Annual Cost Savings} = 8,500 \text{ MMBtu/yr} \times \$8.00/\text{MMBtu} = \$68,000$$

Table 7.40 - Recoverable Heat from Boiler Blowdown (MMBtu/hr)

Blowdown Rate % Boiler Feed Water	Steam Pressure, PSIG				
	50	100	150	250	300
2	0.45	0.5	0.55	0.65	0.65
4	0.90	1.0	1.1	1.3	1.3
6	1.3	1.5	1.7	1.9	2.0
8	1.7	2.0	2.2	2.6	2.7
10	2.2	2.5	2.8	3.2	3.3
20	4.4	5.0	5.6	6.4	6.6

Based on a steam production rate of 100,000 pounds per hour, 60°F makeup water & 90% heat recovery.
Source: Recovery Heat from Boiler Blowdown - www.eere.energy.gov

7.3.4 Cleaning Industrial Vessels, Pipes and Equipment

Overview

Proper cleaning and sanitation represent a critical practice for such industries as food processing and pharmaceutical and cosmetics manufacturing. For food and pharmaceutical facilities, the U.S. Food and Drug Administration, U.S. Department of Agriculture, and state and local health agencies all have regulations overseeing these processes.

Cleaning and sanitizing is one of the more human-interactive operations within a facility. The use of hoses and spray equipment, physical removal of waste materials, timing of cleaning cycles, and the way in which cleaning equipment is used, are all controlled by the employees responsible for the operation. Any modification of these cleaning and sanitizing procedures requires that employees are part of the improvements. They must be trained, be aware of the need to reduce water use, and most importantly, be allowed to participate in the accomplishments. Some cleaning techniques, such as hand cleaning, the use of spray hoses, "manual scrub and wash down," and "fill and flush" are effective,

Thermodynamic Processes

Most commercial locations have heating and cooling systems. Many are just for air conditioning comfort of users of the building, but some can be integral to the commercial or industrial use of a facility. This section deals with types of heating and cooling systems which use water as the medium for heat transfer.

Cooling Towers

- Instrumentation and metering
- Cycles of concentration
- Drift eliminators
- Other considerations

Boilers and Water Heating

- Instrumentation and metering
- Cycles of concentration
- Steam traps and condensate return
- Nitrogen oxide and other pollution-control considerations
- Other considerations

Air conditioning, refrigeration, process cooling, and dehumidification produce large quantities of “waste” heat that must be dispersed back into the environment. Heating of living- or workspace, humidification, process heating, and water heating all consume large quantities of energy, as well. The interplay of energy and water can have a significant impact on the efficiency with which each of these resources is used. For perspective, consider a cooling tower as a device used to get rid of *unwanted* energy by evaporating water and a boiler as a way to generate energy that will ultimately be thrown away, most often in the form of *unwanted* hot water or steam. In all of these processes, energy conservation will reduce water use and, conversely, water conservation will reduce energy use.

For example, capturing waste heat being rejected from an air-conditioning system for use in a cooling tower to preheat boiler feed-water will reduce both fuel needed to heat the water and the load on the cooling tower. This will result in reduced make-up water requirements for the tower. In another example, the use of cogeneration, such as using a gas turbine to generate electricity and then using the waste heat from the turbine to heat water, is being practiced today. Cogeneration results in both on-site water and energy savings, since the waste energy is reused and not rejected to a cooling system. Upstream, energy and water savings can also be realized.

In this section, the two major water-using devices found in thermodynamic operations, cooling towers and boilers, will be discussed, with recommendations for significant reductions in water and energy use.

Significant reductions in water and energy use can be realized with wise planning of heating and cooling systems, including cooling towers and boilers.

Cooling Towers

Description of End Use

Cooling towers reject heat (unwanted energy). Their most common applications in the commercial sector are to remove heat generated in a manufacturing process and for air conditioning and refrigeration equipment. Warm water from process or cooling equipment is introduced at the top of a cooling tower and allowed to trickle over a packing material, such as plastic corrugated fill. The water breaks up into a film and droplets to maximize surface area. Air is pulled or blown through the fill material, contacting the warm water and causing evaporative cooling. The water collected in the basin at the bottom of the tower is recirculated to the process or cooling compressor unit. The recirculating water undergoes a temperature change of about 10° Fahrenheit (F) through this process. The water is usually cooled to within 10° F of the wet-bulb temperature, which averages 53° F yearly and 57° F in the summer in the San Francisco Bay area.

There are two basic tower configurations. Counter-flow towers draw air from the bottom, while water is sprayed onto the top of fill material in the tower (see diagram below). With cross-flow towers, air is drawn in from the sides, across the fill, while water is sprayed in from the top in a manner identical to counter-flow configurations. Fans can be located at either the outside or the bottom of the towers (forced-draft) or on top of the tower to draw the air out the top (induced-draft).

Typical Counter-flow Cooling Tower Configuration

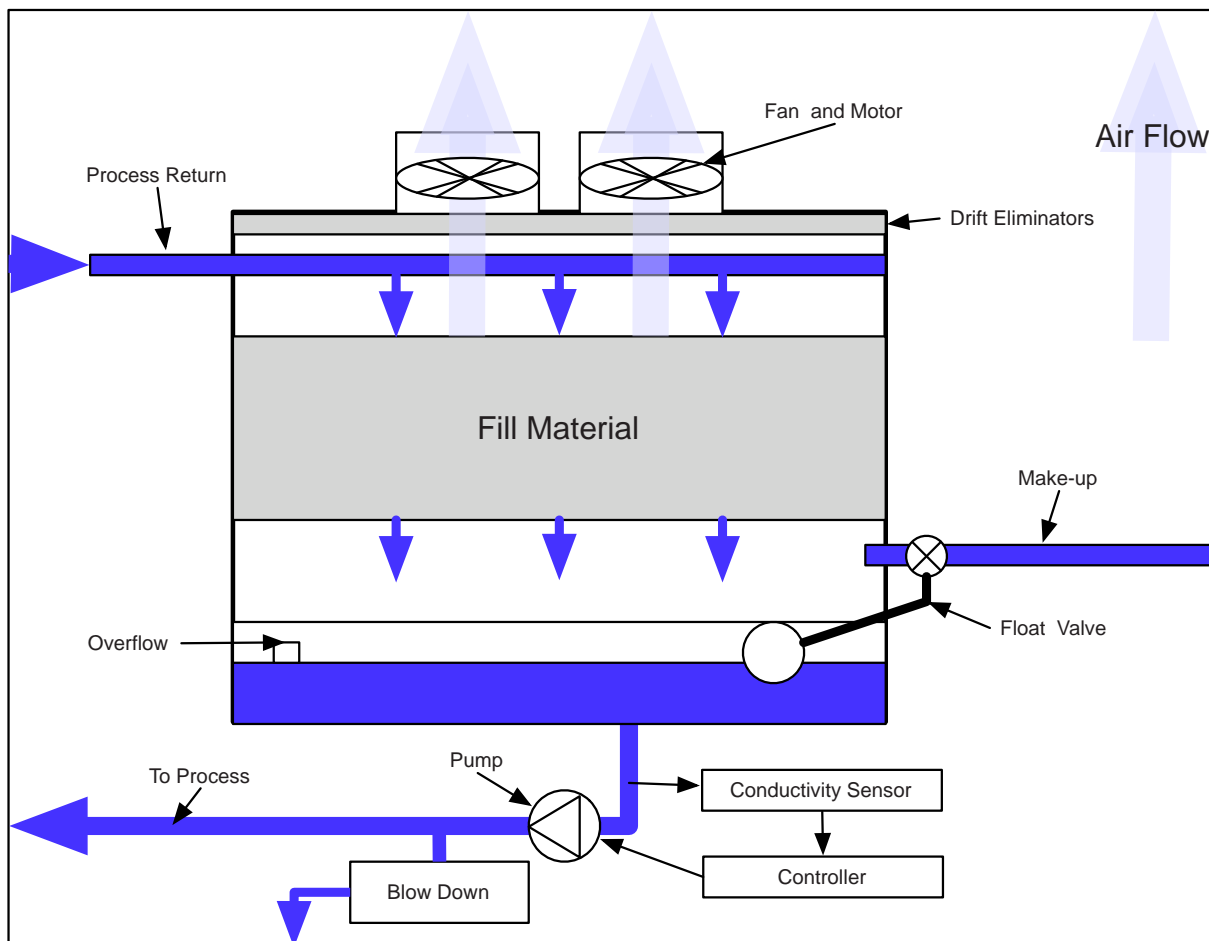



Marley Counter-flow Towers



- through make-up from potable and/or non-potable sources
- when rain falls directly on top of the tower (this represents a negligible amount)
- in the case of process cooling, from a leak in the heat exchanger, because the water being cooled is under higher pressure than the water in the cooling-tower loop

There are four ways a cooling tower can lose water which must then be replaced. The equation for make-up water is:

$$M = E + B + D + L$$

Where

M = Make-up

E = Evaporation

B = Blowdown

D = Drift and wind loss

L = Leaks, overflows, and other losses

A tower can lose water through normal cooling-tower operating processes and can be controlled by proper design and operation, as well as by tower and recirculating-water system malfunctions and problems. An alarm to detect water overflowing the stand-pipe can alert operators to this problem, but leaks can occur under the basin, in the process pipes, and even through faulty blow-down valves and leaking pump seals. These leaks can be detected by proper design and the instrumentation used to control the tower.

Evaporation and Blowdown

Evaporation is a function of the heat added to the water. Approximately 1,000 British thermal units (Btus) can evaporate one pound of water or 8,340 Btus to evaporate one gallon of water. One ton-hour is equal to 12,000 Btus. Therefore, 1.44 gallons of evaporation are required to dissipate one ton-hour of rejected heat.

As the water evaporates, the dissolved minerals and salts in the make-up water remain behind. Additional water must be added (make-up) and some of the water in the basin periodically discharged (blow-down) to keep these minerals from building up and causing scaling and corrosion. The concentration of the minerals (salinity) in the blowdown divided by the concentration of the minerals in the make-up water is called the cycle of concentration. This concentration of minerals is called TDS and is reported in milligrams per liter (mg/l) or parts per million (ppm). Since the electrical conductivity of the water is related to its TDS, conductivity measured in microsiemens is often used in place of TDS. For example, if the conductivity of the make-up water is 100 microsiemens and the conductivity of the blowdown is 500 microsiemens, the tower would be operating at five cycles of concentration. For pure salt (sodium chloride) the ratio of TDS to conductivity is 0.5, but this ratio is dependent upon the types of cations and anions present. Multivalent cations, such as calcium and magnesium, will increase this ratio. Hard waters often have a TDS to conductivity (microsiemens) ratio of 0.6 or higher. This simply means the local cooling-tower operator or treatment-chemical provider must be aware of this ratio. Many test for chloride levels as a way to determine where the conductivity should be set.

Chemicals can be added to the tower to prevent scaling and corrosion and to kill bacteria that cause slime to grow on heat-exchange surfaces, including harmful bacteria such as legionella. Side-stream filtration is often used to remove sediment and dirt that accumulates in a tower from particulates, insects, and other debris in the air as it flows through the tower. Since the water is cleaner, it helps reduce biological activity and fouling of the heat-transfer surfaces, which often results in being able to increase the cycles of concentration. The water in the basin can also be treated through side-stream softening, which

keeps hardness and, therefore, scaling under better control and reduces the need to add acid to the tower, which is a conventional chemical treatment process.

Until recently, chemical treatment, softening, and filtration were the only proven methods available for cooling-tower treatment. Some now employ membrane softening or TDS removal to the make-up water by the use of nanofiltration or reverse osmosis. This allows very high cycles of concentration to be achieved in the tower, but the reject streams from the membrane processes can be in the range of 20 to 40 percent of the water treated. If there is another use for these reject streams, such as irrigation, this can prove to be a water-saving technique, but if no such use can be found, the reject stream simply replaces the blowdown stream from the tower as water being discharged to the sewer. New technologies are emerging that hold the promise of significantly reducing or eliminating the use of chemicals. There is still much controversy in the cooling-tower profession about the efficacy of these methods. Some appear to work well for certain water chemistries, but not for others. The user should be cautious and investigate each technology carefully before using it, in order to be sure it works for their system and water chemistry.

Drift and Wind

Another type of water loss derives from drift and wind. It is caused by the entrainment of small droplets of water in the air stream as the fans force air through the tower or from wind blowing through the tower. If no drift eliminators were used, drift loss would range from 0.30 to 0.45 gallons per ton-hour. Manufacturers now offer eliminators that reduce this to approximately 0.001 percent for counter-flow towers and 0.002 percent for cross-flow towers. With these very-efficient eliminators, drift loss becomes negligible. For towers that control blowdown by a set flow volume to the sewer, drift eliminators can save significant volumes of water. Where conductivity controllers are used to manage when blowdown occurs, drift loss will offset blowdown and thus not impact make-up-water volumes. Drift eliminators significantly reduce aerosols containing bacteria such as legionella, as well as particulate deposition and salt deposits.

For air conditioning and refrigeration, the efficiency of the equipment significantly impacts water use, since approximately 90 percent of the compressor-generated heat is rejected to the tower. The more efficient the compressor equipment, the less compressor heat is rejected to the tower. For an inefficient compressor system with an energy-efficiency ratio (EER) of only 12 Btus per watt hour (1.0 kWh/ton-hr), the total evaporation per ton-hour of air conditioning rises from 1.44 gallons to 1.81 gallons. In contrast, a unit with an EER of 24 (0.5 kilowatts/ton-hour) uses half the electricity to produce the same amount of cooling. Evaporation would be decreased to 1.62 gallons per ton-hour: a 10 percent decrease in evaporation. The table below compares EERs to other commonly used terms for air-conditioner efficiencies.

Air-Conditioner Efficiency Comparison

Kilowatts per Ton	Energy Efficiency Ratio (EER)*	Coefficient of Performance
<i>Kilowatt-hours /ton-hour</i>	<i>Btus/Watt-hour</i>	<i>Btus out/Btus in</i>
2.0	6.0	1.8
1.5	8.0	2.3
1.0	12.0	3.5
0.5	24.0	7.0

*EER is the energy-efficiency ratio at the design temperature and is comparable to the other parameters in this table. Seasonal energy-efficiency ratios (SEERs) are adjusted for an assumed seasonal variation in climatic parameters.

Cycles of Concentration

The cycles of concentration also significantly impact water use per ton-hour. For example, if a tower is used to cool a compressor with a 24 EER (0.5 kWh/ton-hour), and the tower is operated at only 2.0 cycles of concentration, water evaporation is 3.4 gallons per ton-hour. At 5.0 cycles of concentration, however, water use would be only 2.0 gallons per ton-hour. Conductivity controllers reduce water use by controlling blowdown rates.

For potable water typically found in the San Francisco Bay area, five cycles of concentration should be achievable. Five cycles of concentration provide a good minimum level of conservation, but if higher levels are economically feasible, more water savings will be achieved. However, for many areas in the world, the quality of the water, high hardness, silica, and TDS may limit the cycles of concentration that can be achieved economically. This will also be true for the use of alternate sources of water, such as reclaimed water. Based upon information provided by Evapco, Marley, and Baltimore Air Coil literature and experts, unless the make-up water is treated by softening or TDS removal prior to being introduced to the tower or by side-stream softening or similar treatments, the cycles of concentration may be limited. For make-up water containing 200 mg/l of hardness, measured as calcium carbonate, four cycles of concentration may be the economic limit. San Antonio, Texas, which has very hard water, requires a minimum of four cycles of concentration for towers operating within its jurisdiction. Also, since very high TDS may require special materials to be used to control corrosion, most commercial tower operators keep the TDS in the tower's basin and recirculating water below 1,500 mg/l. (Remember, the conductivity of the water as it relates to TDS is dependent upon the actual water chemistry.) In a similar manner, manufacturers recommend that silica levels in tower basins and recirculating water, measured as silicon dioxide, be kept below 150 mg/l. The important factor to remember is that the economic level of cycles of concentration will depend upon water and sewer costs, the materials used to construct the tower and heat exchangers, and the cost of the treatment that must be provided.

It is important to look at all the costs associated with operating a cooling tower in order to compare them with the use of an air-cooled unit. The savings in energy must be balanced against the total costs of tower operations, including water and wastewater, chemicals, energy for fans and pumps, labor, capital investment, and adverse impacts, including high dissolved solids in the wastewater, deposition from drift loss, and aerosols containing bacteria such as legionella.

Therefore, all new towers should be properly instrumented with:

- make-up and blowdown meters
- conductivity controllers for blowdown
- overflow alarm systems
- drift eliminators

The effect of both cycles of concentration and compressor efficiency upon water use per ton-hour in a tower with modern drift eliminators is summarized in the figure on the following page.

Facility managers and owners who contract services for cooling-tower operations should include requirements for the minimum cycles of concentration to be achieved by the cooling tower. In regions with high water quality (low TDS), a minimum of five cycles of concentration should be achievable. For water supplies to cooling towers in general, the following guidelines should be followed:

- for make-up waters having less than 200 mg/l (200 ppm) of total hardness, expressed as calcium carbonate, a minimum of 5 cycles of concentration, based upon a ratio of the conductivity of the water being discharged (blowdown) divided by the conductivity of the feed (make-up) water(s), is recommended;

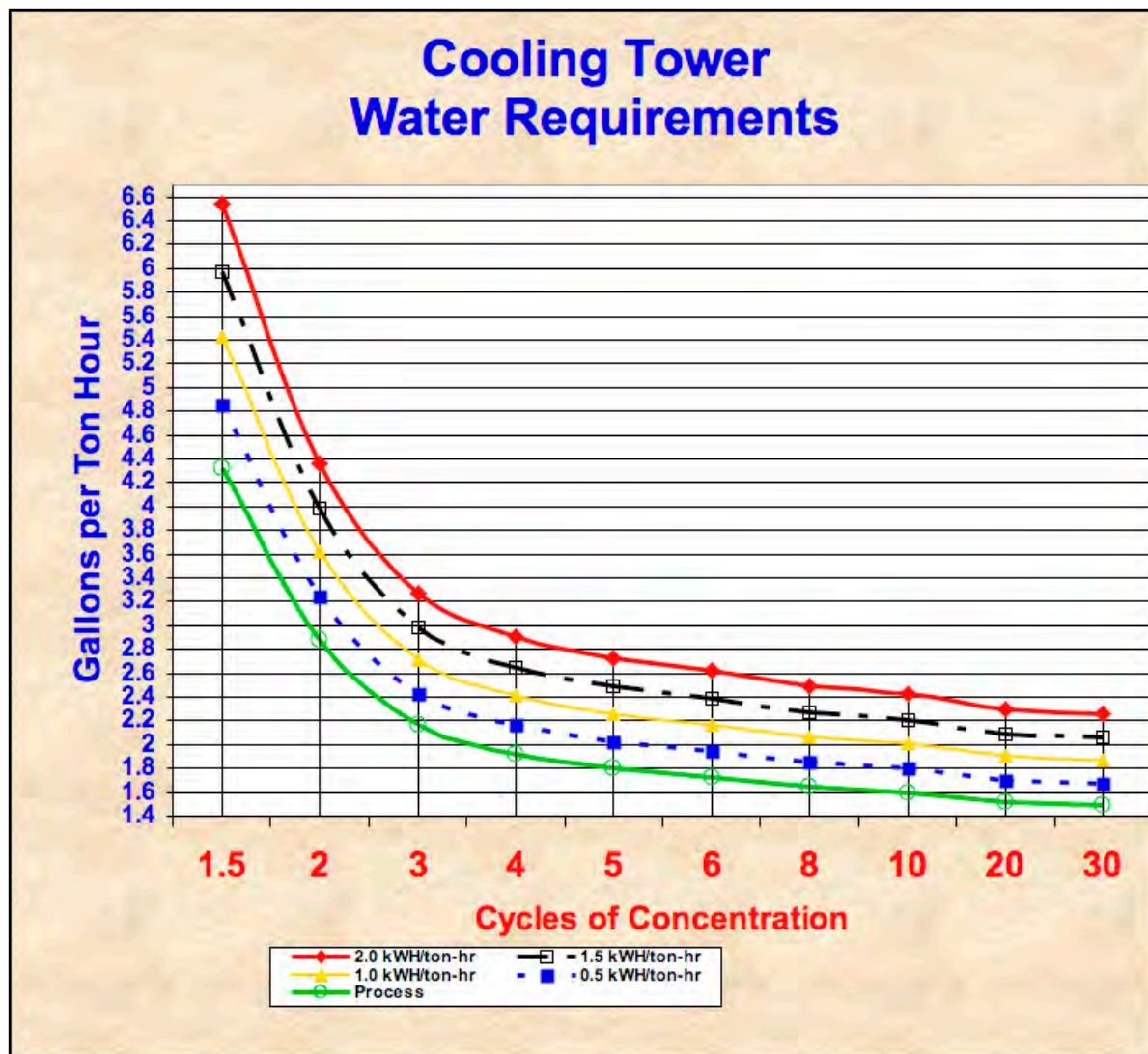

- for make-up waters with more than 200 mg/l of total hardness, expressed as calcium carbonate, a minimum of 3.5 cycles of concentration, based upon a ratio of the conductivity of the water being discharged (blowdown) divided by the conductivity of the feed (make-up) water(s), is recommended, unless side-stream softening or another similar treatment method is employed.

Exception: Where the blowdown's TDS concentration exceeds 1,500 mg/l (1500 ppm) or silica exceeds 150 mg/l (150 ppm) measured as silicon dioxide before the above, cycles of concentration should be limited to achieve these parameters, unless additional water treatment is employed.

Cost-Effectiveness Analysis

Tower operating-cost considerations when selecting an air or water-cooled system include the following:

- Capital cost for towers, installed, is about \$100 per ton. Life expectancy is about 15 years.
- Air-conditioning towers operate about 2,600 hours a year, so capital cost is about 0.25 cents per ton-hour. Refrigeration towers operate about 3,500 hours a year at a capital cost of about .19 cents per ton-hour.
- Towers consume 2.2 gallons of water per ton-hour for a cost of about 1.5 cents per ton-hour.
- Energy use is about 0.04 kWh or 0.3 cents per ton-hour.
- Chemicals, operations and maintenance (O&M) of about 0.15 full-time-equivalent employees (FTE), and other maintenance add an additional 0.5 cents per ton-hour, for a total of about 2.8 cents per ton-hour.



Baltimore Air Coil Cross-Flow Tower

Savings Due to Increased Cooling-tower Efficiency

A detailed analysis of the increase in cooling-tower efficiency will depend upon local conditions. However, if a tower's cycles of concentration increase from 2.0 to 5.0, the water savings will be 1.2 gallons per ton-hour, since the 3.2 gallons needed per ton-hour at 2.0 cycles decreases to 2.0 gallons per ton-hour at 5.0 cycles. The added savings in water and wastewater alone will be 0.9 cents per ton-hour. For a 500-ton tower operating at a 30 percent annual load factor, water use at 2.0 cycles is 4.2 million gallons per year, while the same tower operating at 5.0 cycles will use only 2.6 million gallons, for a savings of 1.6 million gallons a year.

Recommendations

Proven Practices for Superior Performance

- Require a life-cycle analysis, including all operating, capital, and personnel costs, to determine whether the use of a cooling tower is more cost-effective than air cooling.
- Require all cooling towers to be equipped with conductivity controllers, make-up and blow-down meters, and overflow alarms.
- Require towers to be operated at a minimum of five cycles of concentration in regions with high water quality (low TDS) for towers using potable water, depending upon the water chemistry of the make-up water used, including considerations for reclaimed water or on-site sources.
- Require all towers to have high-efficiency drift eliminators that reduce drift loss to less than 0.002 percent of circulating water volume for cross-flow towers and 0.001 percent for counter-flow towers.
- Prohibit cooling towers for single-family residential use.

Unilux Steam Boiler



Fulton Boiler Works Hot-Water Boilers



Additional Practices That Achieve Significant Savings

- Evaluate an entire building or process for maximum energy efficiency, since a more efficient building will reject less heat to the cooling tower.
- Evaluate the possibility of waste-heat recovery, since this heat will be put to beneficial use and will not be rejected to the tower.
- Require operator training.
- Prohibit cooling towers of less than 100 tons for commercial air-conditioning systems.
- Establish a utility-wide monitoring and reporting process.

References

Cooling towers, air-cooled heat exchangers, and industrial coolers (or heat-rejection equipment)

www.seav.sustainability.vic.gov.au/manufacturing/sustainable_manufacturing/resource.asp?action=show_resource&resourcetype=2&resourceid=28.

Hoffman, H. W. (Bill). 1994. **Analyst Manual for Institutional and Commercial Water Use Surveys**. Texas Water Development Board.

Holdaway, Ron, P.E. February 2004. "Water Treatment as Insurance." **Maintenance Magazine**.

Parke, Steven A. **Ozone Treatment for Cooling Towers**. Pacific Northwest National Laboratory. Richland, Washington.

Boilers and Water Heating

Description of End Use

The term "boiler" is used to describe both steam boilers and water-heating systems in many commercial operations. Steam systems are used for process heat for hospitals, large kitchens, bakeries, and dry cleaning. Historically, steam radiators were used for building heat, but their use is limited now. The term is also used in many commercial operations to describe equipment used to heat water for processes, building heating, and hot-water supply.

Steam Boilers

Steam boilers produce steam by boiling water. The temperature of the steam depends upon the level of pressure at which the boiler works. Low-pressure boilers are used for most commercial operations. High-pressure boilers are more commonly used for power generation and industrial processes. Water fed into the boiler is heated and turned into steam, which is then either used in a consumptive manner or condensed and returned to the boiler. Boilers are rated by "boiler horsepower," defined as enough energy to evaporate 34.5 pounds of water at a temperature of 100° Celsius (C) (212° F) into steam at 100° C per hour, or about 33,478.8 Btus per hour, based upon steam tables. About 80 percent of boilers in use today are of the fire-tube type (Alken–Murray).

Boiler feed-water must be treated before it is used to remove oxygen and dissolved gasses (de-aeration), softened to remove hardness that can cause scale, and filtered or clarified to remove particulates. Since very pure water is required for higher-temperature boilers, the water is often passed through an RO system or a deionization resin. Lower-pressure boilers can use water of lesser quality. Chemicals are often added to prevent silica scaling, control corrosion, and scavenge remaining oxygen.

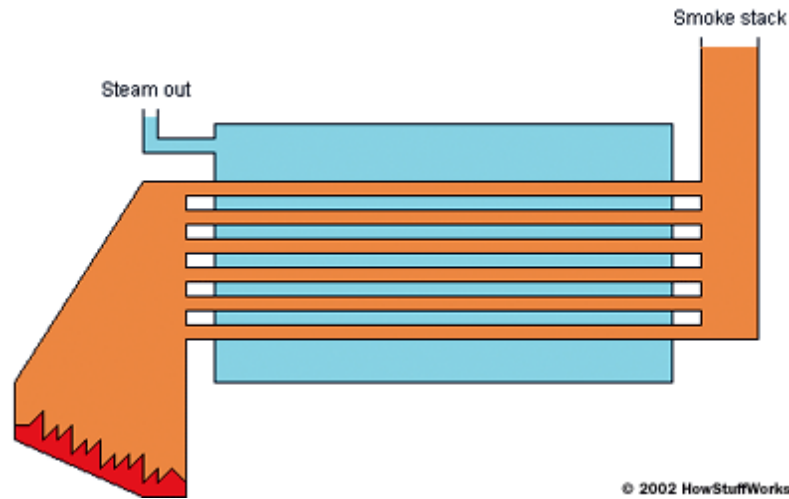

Diagram of a Typical Fire-Tube Boiler

As the water in the boiler turns into steam, dissolved minerals remain behind and the steam leaves as pure water. In a perfect system, the steam would be recondensed and all returned to the boiler. In actual operation, steam is lost or consumed, and more water must be added. To control dissolved solids, some of the water in the boiler must be discharged as blowdown. This water is drawn from near the top of the boiling-water level in the boiler chamber, since this is where the maximum concentration of minerals builds up as the water turns to steam. This is called “top blowdown.” Over time, minerals and rust build up in the bottom of the boiler to form “boiler mud,” which must be removed through a process called bottom blowdown.

Typical top-blowdown rates range from 10 to only 2 percent of boiler feed — equivalent to 10 to 50 cycles of concentration. Many boiler operators practice discretionary continuous top blowdown, in which a valve is left partially open. This practice can waste significant volumes of water. Conductivity meters that can operate at the high temperatures and pressures of a boiler can control this blowdown and minimize water use.

Bottom blowdown, usually a much smaller volume done on a predetermined schedule, is based upon the operational characteristics of the boiler. Bottom blowdown water should be observed periodically to ensure that only “muddy” water is being discharged. The use of blowdown systems to recover heat has been successful with energy recovery, but the high mineral composition of the blowdown makes this water unsuitable for reuse.

Steam does its work by recondensing to water and releasing its heat of vaporization. For efficiency and water- and energy-conservation, this condensate should be returned to the boiler, since it is pure, very-hot water. Adequately sized steam traps coupled with condensate-return pumps comprise a good system. Since condensate can pick up rust, particulates, and other contaminants, condensate polishing with filters or ion-exchange resins is sometimes practiced. According to most codes, if condensate return is not feasible, water must be cooled prior to discharge to a sanitary sewer. This offers additional water-conservation opportunities, as will be seen with steam sterilizers in medical facilities.

Hot-Water Boilers

Hot-water boilers are water-heating systems and do not involve the production of steam. The term “boiler” is used, but these are actually just large water-heaters. There are two major system configurations: open and recirculating. Open systems provide hot water to an end use, such as bathing, laundry, or dishwashing operations. The water is not returned to the heating system. These can either be direct-supply systems or have loop piping where the hot water is circulated with a pump back to the water heater. Open systems are usually found in food service and laundry operations.

Recirculating systems are usually found in hotels and large buildings where having hot water instantaneously is desired. Recirculating systems are also commonly used for building heating, where hot water is supplied for space heating, using either air heat-exchange (either forced or convection) or hydronic floor-heating systems. The water in the closed loop is generally treated to help control corrosion and scaling. Additional water is needed only to make up for leaks and periodic changes of the water.

Water-Savings Potential

Steam boilers offer many unique opportunities for water savings. Conductivity controllers, the proper use of steam traps and condensate-return systems, and good energy-conservation practices can help reduce boiler feed-rates. Conductivity controllers reduce water use by controlling blowdown, while good steam traps and condensate-return systems ensure that high-quality, hot steam condensate is returned. Much depends upon the size and application of the boiler. The amount of make-up water needed depends upon the amount of condensate returned. The following examples illustrate how these improvements in water-use efficiency add up to water savings.

Examples:

1. A boiler produces 5,000 pounds of steam per hour (equal to 599.5 gallons of water at 8.34 pounds per gallon). This is equal to 5.0 million Btus per hour at 1,000 Btus per pound.
2. The conductivity controller for blowdown is set at 10 cycles. This means 10 percent of the water fed to the boiler will be discharged as blowdown.

$$M = CL + B$$

Where:

M = Makeup

CL = Condensate Loss

B = Blowdown

Cycles of concentration also equals M/B. For 10 cycles M/B = 10.1 or blowdown = 1.0 divided by the cycles of concentration = 0.1M

$$M = CL + (0.1M)$$

3. Eighty (80) percent of the condensate is returned.

The boiler produces 5,000 pounds of steam, but only 80 percent is returned. The make-up to replace this is equal to 1,000 pounds, or 119.9 gallons (1,000 pounds/8.34 pounds per gallon).

$$M = 119.9 + 0.1M$$

$$0.9M = 119.9$$

$$M = 119.9/0.9 = 133.2 \text{ gallons}$$

If the return rate is increased to 95 percent, only 250 pounds or 30.1 gallons of condensate would be lost. If the cycles of concentration remain at 10, the make-up water would equal:

$$M = 30.1/0.9 = 34.5 \text{ gallons}$$

or a savings of $133.2 - 34.4 = 78.7$ gallons per hour (gph).

If the cycles of concentration are also increased to 35, the make-up to blowdown ratio would be $1/35 = 0.0286$. Therefore,

$$\text{Blowdown (B)} = M \times 0.0286$$

$$M = 30.1 \text{ gallons} + 0.0286M$$

$$M = 30.1/(1.0.0286) = 30.1/0.9714 = 31.0 \text{ gallons.}$$

This is equal to a savings of 133.2 gallons - 31.0 gallons = 102.2 gallons or 77 percent.

Hot-water boilers produce hot water for all types of uses, ranging from domestic use to building heating with hydronic and convective systems. Each use presents different opportunities for saving water, depending upon the operation of system. The two major water-saving actions related to hot-water boilers are good end-use water conservation and preventing leaks in the distribution system.

Cost-Effectiveness Analysis

Example for Steam-Boiler Conductivity Controllers (taken directly from the Pacific Northwest Pollution Prevention Resource Center, 20057).

Assumptions:

- Automatic conductivity blowdown-control system reduces the blowdown rate from 8 to 6 percent.
- Natural-gas-fired steam boiler operates continuously at 150-psig (pounds per square inch gauge), 100,000 pounds-per-hour.
- Make-up water temperature of 60° F.
- Boiler efficiency of 82 percent.
- No heat exchanger for recovery of heat from blowdown water.

Boiler Feedwater Savings

- Before installing control system:
 - » $100,000 \text{ pounds per hour} / (1-0.08) = 108,695 \text{ pounds per hour.}$
- After installing control system:
 - » $100,000 \text{ pounds per hour} / (1-0.06) = 106,383 \text{ pounds per hour.}$
- Water Saved: $108,695 - 106,383 = 2,312$ pounds per hour.
- At 8,760 operating hours per year, the savings is 20.3 million pounds or 2.4 million gallons per year.

Example for Hot-Water Boiler

Hot-water boilers do not have a blowdown or discharge. These are very large water-heaters. Savings are achieved by reducing hot-water use. The value of the hot water saved includes the energy needed to heat the water and the cost of the water and wastewater.

Recommendations

Proven Practices for Superior Performance

Steam Boilers

- Require steam boilers of 200 boiler horsepower (BHP) or greater to be equipped with conductivity controllers to regulate top blowdown.
- Require steam boilers of 200 BHP or greater to have condensate-return meters.
- Require steam-boiler distribution lines and equipment to be equipped with steam traps meeting all codes.
- Require all steam boilers to have make-up meters on the feedwater lines.
- The cycles of concentration at which a boiler operates is dependent upon water chemistry, boiler operating pressure, temperature, and related factors. Maximizing the cycles of concentration will reduce water use.

Hot-Water Boilers

- Require make-up meters on all cold-water feed lines to boilers (water heaters) of more than 100,000 Btus per hour.
- Require make-up meters on lines feeding closed-loop hot-water systems for heating.

Additional Practices that Achieve Significant Savings

Steam Boilers

- Equip all steam boilers with conductivity controllers.
- Operate all steam boilers at twenty cycles of concentration or greater (5 percent or less of make-up water).

Hot-Water Boilers

- Have boiler (water-heater) temperature and make-up meters clearly visible to the operator.

References

- Alken-Murray Corporation. **Why Treat the Water in Your Boiler?** New Hyde Park, New York. www.alken-murray.com/Boilerworks.htm.
- Chana, Vinita; White, Stewart; Howe, Carol; and Meenakshe, Jha. **Sustainable Water Management in Commercial Office Buildings.** Institute for Sustainable Futures. www.isf.uts.edu.au/publications/chanan.html.
- Clayton Industries (17477 Hurley Street, City of Industry, CA 91744-5106). Web site on boilers. www.claytonindustries.com.
- Cohen, Ronnie; Nelson, Barry; and Wolff, Gary. August 2004. **Energy Down the Drain – The Hidden Cost of California’s Water Supply.** Pacific Institute.
- Encyclopedia of Alternative Energy & Sustainable Living.** www.daviddarling.info/encyclopedia/BAE_boiler_horsepower.html.
- Hoffman, H. W. (Bill). 1994. **Analyst Manual for Institutional and Commercial Water Use Surveys.** Texas Water Development Board.
- Hoffman, H. W. (Bill). March 2006. **Building Reduced Water and Wastewater Cost into the Design.** Austin Water Utility. Austin, Texas.

Hoffman, H. W. (Bill), and Sutton, John T. 2003. **State Energy Conservation Office Suggested Water Efficiency Guidelines for Buildings and Equipment at State Facilities.** Texas State Energy Conservation Office.

New Mexico. Office of State Engineer. July 1999. **A Water Conservation Guide for Commercial, Institutional and Industrial Water Users.**

Pacific Northwest Pollution Prevention Research Center. February 2005. **Pollution Prevention Technology Profile: Conductivity Controls in Water Rinsing, Cooling Towers, and Boilers.** Seattle, Washington.

Pollution Prevention International. March 2004. **Commercial, Institutional, and Industrial Water Use Survey Program Final Report.** For Santa Clara Valley Water District.

U.S. Department of Energy. EERE. **Install an Automatic Blowdown Control Program.** Industrial Technology Program Tip Sheet 23.

U.S. Department of Energy. Office of Industrial Technologies. 2002. **Improving Steam System Performance.** www.p2pays.org/ref/21/20921.htm FEMP BMP 6.

3.4 Reducing demand for water: utilities

3.4.1 Blowdown in cooling towers and boilers

A build-up of dissolved solid deposits in cooling towers and boilers can reduce efficiency and cause mechanical damage. Blowdown can be used to prevent this. In order to minimise the quantity of water needed for blowdown, a conductivity probe can be installed. This will initiate blowdown only when the conductivity of the water exceeds a set value.

Water used for other equipment may be able to be recycled and reused for cooling tower make-up water, provided it is of good quality and any chemicals used are compatible with those used in the cooling circuit.

Case study

Water reuse for evaporative condenser and cooling tower make-up water: brewery, Australia

Swan Brewery in Western Australia recycles carbon dioxide purifier cooling water, can rinsing water and refrigeration cooler defrost water. The water is reused in the evaporative condensers and for cooling tower make-up water. The company saves 60 000 kL annually and 10% in wastewater treatment costs.¹

¹ Centre of Excellence in Cleaner Production 2003a



Eco-efficiency action

- Install conductivity sensors to reduce blowdown.
- Add an automatic chemical feed system controlled by make-up water flow.
- Consider alternative sources for blowdown make-up water.
- Reuse blowdown water (particularly from boilers) for other uses such as cleaning.
- Maintain boiler systems regularly to reduce blowdown and maintain boiler efficiency.

3.4.2 Cooling tower operation

To reduce the risk of contaminants collecting in cooling towers and associated piping, the equipment must be cleaned and maintained regularly. Maintenance enhances the tower's efficiency and helps to maximise the equipment's life span.

The installation of a filtration system such as a rapid sand filter or high-efficiency cartridge filter may help to remove suspended materials that degrade the quality of cooling tower water. The reduction of fouling will help to reduce maintenance, the necessity for blowdown, and the loss of heat transfer efficiency. For cooling towers with low flow rates it may be possible to install a filter directly onto the tower outlet. For larger systems with higher flow rates this is not practical, and a side-stream filter is the most economical option.

REDUCING DEMAND FOR WATER: UTILITIES

A valve which is mechanically actuated by a float is utilised on many cooling towers to control make-up water supply. If this is the case, ensure the float is located in a position where it cannot be affected by water movement as a result of wind or water flowing through inlet pipes into the tower.



Eco-efficiency action

- Regularly maintain cooling towers to improve efficiency.
- Operate cooling towers at design specifications (i.e. temperature and flow rate).
- Check for leaks by comparing the ratio of blowdown flow to make-up flow.
- Reduce the cooling load of towers by first recovering heat from the stream to be cooled.
- Use a filtration system to remove from the cooling tower water suspended materials that cause fouling and reduce heat transfer.
- Minimise dust around cooling towers and keep heat exchange areas clean, to maximise heat exchange to cooling water.

3.4.3 Alternative cooling processes

Water can be saved if an alternative cooling medium other than cooling tower water can be found. Check whether direct or indirect contact between existing suitable hot water and cold water streams can achieve the desired cooling. In some cases, where higher water temperatures can be tolerated (up to 40°C), cooling towers can be replaced with air blast coolers; however, any water savings need to be compared with increased energy costs. Another alternative is to use the waste heat elsewhere in the processing plant by installing a heat exchanger.



Eco-efficiency action

- Investigate the feasibility of alternative cooling processes such as air blast coolers.
- Investigate whether other streams are available for cooling by direct or indirect contact.

3.4.4 Boilers and steam generators

Water lost from the boiler system in the form of steam condensate should be recovered as far as possible. Condensate recovery reduces the amount of make-up water required by the boiler to compensate for the condensate loss. Reducing condensate loss can significantly reduce water supply, chemical use and operating costs. A condensate return system also reduces energy costs, because the already hot condensate requires less energy to reheat.

Case study

Condensate recovery improvement: brewery, Australia

Castlemaine Perkins in Queensland used to send condensate at 95–98°C in the engine room to the drain. A condensate return system was installed for \$15 000 to return this water to the boiler. Condensate return was increased by 5% to 70%, saving 2000 kL annually.¹



¹ Castlemaine Perkins 2003

Eco-efficiency action

- Examine the potential to install a condensate return system. Routinely inspect and maintain steam traps, condensate pumps and lines.

3.4.5 Pump seals

Pumps such as liquid ring vacuum pumps use water as a sealing and cooling medium. It may be possible to replace such pumps with dry vacuum pumps to reduce water consumption.

Sealing water on pumps can be recirculated to minimise usage. Alternatively, mechanical seals can now be installed on most pumps that require no sealing water. Such seals reduce water consumption and may reduce operating and equipment costs.

Case studies

Replacement of water vacuum pumps: brewery, Australia

Castlemaine Perkins in Brisbane replaced 14 water seal vacuum pumps with high-efficiency electrical pumps and now saves 8000 kL of water annually.¹

Reuse of vacuum pump wastewater: fish processor, Australia

Port Lincoln Tuna Processors in South Australia produce canned tuna and sashimi. The company uses vacuum pump wastewater and reverse osmosis water permeate for cleaning. Washdown for the plant is now achieved using 85% recycled water.²

¹ Castlemaine Perkins 2003

² South Australian Environmental Protection Agency 2003a



Eco-efficiency action

- Recycle pump sealing water or collect for use for other purposes such as cleaning.
- Investigate installing mechanical seals that require no sealing water on pumps.
- Investigate the use of dry vacuum pumps.

Bottle Washer Case Study

Water recycling was implemented on a bottle washer for a system with a pre-rinse followed by three caustic and three water sections. The solution in the first caustic section of this system is filtered and recycled to this first section. In the third caustic (spray) section, an air fan was installed, to minimize the carryover of caustic to the warm water sections.

In the last rinsing section, rinsing was previously performed with three nozzles for the inside and one for the outside of the bottle. The rinsing at this line was modified to two inside spray nozzles operating with 7 kl/h fresh water. This rinse water is then collected, treated and used for one inside rinse and one outside rinse nozzle (overall, 7 kl/h). This rinse water is again collected and reused:

- first for a cold water bath
- second for a cold water rinse
- third for a warm water rinse
- finally for the pre-rinsing of the bottles

The treatment of the rinse water consists of a buffer tank, two parallel membrane filters of 5 µm and disinfection by UV lamps.

The fresh rinse water flow is adjusted according to the running of the bottle washer, presence of bottles, bottle speed, water level and temperature.

These measures resulted in a decrease of the specific water consumption (bottles of 1 and 1.5 l) from 0.6 to 0.4-0.5 l/bottle. The total fresh water consumption decreased from 39,590 to 23,960 kl/year and is equal to a water reduction of 39%.

3.3 | Warehousing

Not much water is used in the warehouse, with most being used only for cleaning purposes. Consider using water from final rinses or other clean streams from the brewery process for this application.

Make people aware of water wasting, as described earlier, and optimize the hoses used. In many cases, high pressure hoses, which use less water, can be used effectively in warehouse areas.

3.4 | Support Systems (Utilities)

Support systems include all utility and powerhouse operations. Often, water used for sanitary needs and outdoor landscaping is included in this category.

Best Practices - Cooling Towers

Evaporative cooling is a common and efficient way of dissipating thermal loads. Cooling towers and evaporative condensers require significant quantities of 'make-up' water to compensate for losses associated with evaporation, drift (or mist) and blowdown (or purge).

A key parameter used to evaluate cooling tower operation is "cycles of concentration" (sometimes referred to as cycles or concentration ratio). This is calculated as the ratio of the concentration of dissolved solids (or conductivity) in the blowdown water compared to the make-up water.

Cooling Towers⁷



Water use can be minimized by:

- Maximizing the cycles of concentration. Many systems operate at two to four cycles of concentration, while six cycles or more may be possible. Increasing the cycles from three to six will reduce cooling tower make-up water by 20%, and cooling tower blowdown by 50%
- Undertaking routine surveys of cooling towers and evaporative condensers for leaks and losses, and taking remedial action as soon as possible
- Repairing or replacing poorly operating blowdown valves promptly
- Checking overflows (e.g., make-up water tank) and ensuring they are not overflowing

Best Practices – Steam Generation

Boilers and steam generators consume varying amounts of water depending on the size of the system, the amount of steam used, and the amount of condensate returned.

Boilers⁹



The key to operating an efficient steam boiler is to maximize steam generation and minimize losses to sewer by:

- Inspecting the boiler, condensate system and steam traps to find and promptly repair leaks.
- Properly insulating steam and condensate pipes and hot well to decrease steam requirements and heat loss.
- Minimizing blowdown volumes by ensuring water treatment is optimized and blowdown automated.
- Ensuring condensate return is maximized and the system is working effectively. Recovering

condensate for re-use will reduce water use, chemical use and energy consumption.

Best Practices - Compressors

Refrigeration compressors often need cooling water. Since they produce excessive noise, these compressors tend to be isolated and only inspected when needed.

Compressor⁸



If possible, consider changing to a closed-loop system with a cooling tower, or otherwise, integrate the compressor cooling with another chilled water loop, like fermenting cooling. This chilled water loop is particularly effective when the brewery has several water cooled units. A small bleed will be needed for hygiene reasons.

If a closed-loop system is not possible, there may be a potential to reuse the water for various washing operations described earlier, like a cask washer or the CIP system. In this case, connect a solenoid valve to the cooling water supply to automatically cut off the supply when the compressor stops. Also install a frequency control to the pump of the cooling water supply to prevent manual tampering of the flow.

Air-Cooled Compressors

When replacing a water-cooled compressor, consider the use of an air-cooled unit to save water and during

cool ambient conditions, it may save energy as well.

Some (tank) radiators tend to accumulate ice due to humidity in the area. Do not use water to remove this ice. It will need an excessive amount of water and will increase the humidity even more. It is more efficient to use excessive heat or hot water or, in low peak hours, use electrical heating.

3.5 | Food Service

Many craft breweries include a brewpub within their operational footprint. In these instances, water and wastewater issues associated with food and drink services must be addressed. There have been a number of best practices identified for saving water in food service establishments. The National Restaurant Association has developed the Conserve Sustainability Education Program. It is an excellent online resource to help restaurants reduce operating expenses and leave a lighter footprint on the environment. Many of the ideas presented in this section are from the Conserve program.

Also check with your local water supplier for free water audits or rebates and incentives for restaurant water savings.

Top Water-Saving Opportunities For Restaurants/ Brewpub

- *Metering (control and predict your water use)*
- *Retrofit*
- *Use low-flow pre-rinse spray valves, faucets, toilets and urinals*
- *Add aerators*
- *Add insulation*

Water is a significant part of restaurant operations. It is used for cooking, cleaning, food production, customer consumption, and sometimes for landscaping. Conserving hot water is always a smart idea, because it trims two bills: water and the electricity or natural gas used to heat it.

A brewpub can be split into the kitchen area, the dining and restroom area and the outside of the brewpub (landscaping). Similar as with the brewing process, it all starts with some generic measures, like employee awareness and understanding water use.

Training employees on water usage and how they can contribute will help the understanding and acceptance

of measures.

Sierra Nevada Brewing Company Taproom Water Saving Projects

- *Replace Bathroom Faucet Aerators - 789,983 liters/year (immediate payback)*
- *Retrofit flush valve toilets w/ dual flush handles - 288,811 liters/year (0.7-year payback)*
- *Install Air-Cooled Ice Machine - 3,159,930 liters/year (1.5-year payback)*
- *Replace Pre-Rinse Spray Valves - 988,186 liters/year (immediate payback)*

Best Practices - Dishwashing

When cleaning dishes and plates, avoid using running water to thaw or rinse food. Instead, gradually thaw frozen food in a refrigerator. Wash vegetables in ponded water; do not let water run in preparation sink. Train employees to immediately scrape & wipe plates.

Use squeegee scrapers and avoid rags which soak water. Soak dirty pots and pans instead of rinsing them in running water. Pre-soak with sustainable cleansers, using baking soda to pre-soak pots and vinegar to cut grease.

Dishwasher Tips

- *Run fully loaded dish racks*
- *Pay attention to the pressure gauge - only 20 psi needed*
- *If conveyor-style dishwasher, make sure it's in auto mode*
- *Turn off at night and when idle for long periods of time*
- *Add or maintain wash curtains*
- *Repair leaks*
- *Replace worn spray heads*
- *Soak heavily soiled dishes*
- *Use heat exchangers (usually called an indirect exchanger - it's a plate heat exchanger so that the wastewater doesn't come in contact with incoming water)*
- *Check that water temperatures are between 120 to 130 degrees and the booster heater is used to reach 180 degrees if the dishwasher is high-temperature.*

- Use drip pans and splash guards to catch breaching or parts.
- Practice manual cleaning procedures before washing.
- Only wash equipment once dry waste has been removed.
- Many of the cooking, autoclaving, drying, and similar operations require steam. Thus, capturing and returning steam condensate represents a water saving measure.

General - Alternate Sources of Water and Recirculated Water Use

Use of alternative sources and recirculated water is a best management practice for all industries. Issues and uses specific to Food Processing and Beverage Manufacturing are discussed in this section. These BMPs may include:

- Recycling water within the plant
- Use of alternate sources for non-food processing areas
- Reuse of plant effluent for irrigation

Limitations on Water Reuse

The U.S. Federal Food and Drug Administration and the U.S. Department of Agriculture's strict guidelines for food safety often means that much of the water used in meat and poultry processing, as well as other food processing operations, may only be used once. The use of ozone and membrane treatment of wastewaters are techniques now being tested within the poultry industry, and the use of recovered water for non-contact uses such as cage cleaning, dust control, and others are now common.

Wastewater Reuse for Irrigation

One of the most important considerations is that most food processing wastewaters can be used for irrigation. Nutrients in the wastewater can help fertilize the crops, and irrigation removes pollution from receiving streams or wastewater treatment plants. When examining food processing water use, this reuse is often left out of the analysis.

Where water is to be used for crop irrigation, water quality (e.g., salts, especially sodium salts) becomes a major concern. Organic loading, irrigation rates, nutrient levels and other factors are important to consider. Many companies are using potassium salts for recharging softeners and pH adjustment, isolating waste streams with very high concentration of salts, and providing "end-of-the-pipe" treatment technologies to make their effluent usable for irrigation. (See the *Manual of Good Practice for Land Application of Food Processing/Rinse Water*. Prepared for the California League of Food Processors 2007 by Brown and Caldwell)

Examples of water reuse practices may be found in the canning, dairy, beer and wine, and frozen foods industries. Many canneries follow this practice as long as sodium levels and total salinity remains within bounds.

Land Application Reuse Regulations

Regulations specific to land application of wastewater from food processors include:

- Porter Cologne Act - Reuse cannot impact beneficial uses of groundwater
- Basin plans - Defines the beneficial use of water for each region
- Anti-degradation policy
 - Protects groundwater
 - Requires the use of Best Practicable Treatment and Control

7.2.2.4 The High-Tech Industry in California

Overview – High Tech

Starting in the 1950s, high technology (or high-tech) companies began a rise in California that has continued through the present day. Silicon Valley and other centers of high-tech in Southern California saw the development of the silicon-based integrated circuit, the microprocessor, the microcomputer, and other key technologies. Products produced by high-tech include microprocessors, personal computers and peripherals, video games, and a wide array of mobile devices such as MP3 music players, cell phones, smart phones, and tablets, resulting in an increase in networking systems and datacenters.

In the 1980s and 1990s, California led the nation in the number of facilities built to fabricate semiconductors and other microelectronic components. Towards the end of the 1990s the trend began to reverse. High-tech companies began building new facilities elsewhere, and the state's older facilities began to shut down. Some of the reasons for this shift include the high cost of doing business in the state, an increasingly skilled global workforce, and large incentives offered by other states and countries. As a result, a significant fraction of high-tech manufacturing has moved out of the United States to East Asian countries, especially Japan, China, and Taiwan. By 2009, the United States semiconductor production capacity had slipped to just 17 percent of global capacity, down from 25 percent only two years earlier.¹²⁸ This net migration of high-tech microelectronic manufacturing has been pronounced in California, and it is true not just with semiconductors, but also with networking equipment, servers, computers, peripherals, and mobile devices.

According to U.S.DOC information, overall employment in the high-tech industry in California has declined by 100,000, from 298,000 employees in 2002

¹²⁸ <http://www.manufacturingnews.com/news/10/0212/semiconductors.html>

3.9 Water and wastewater recycling and reuse

Some wastewater streams are relatively clean and can often be recycled or reused onsite. If the quality of wastewater streams is not suitable, some form of treatment may be necessary to make the water suitable for reuse. In some cases it may be necessary to segregate wastewater systems to allow for reuse, as previously discussed. Food health standards will not allow the reuse of water on edible product or in a process where water may come into contact with edible product.

Some incentives that have been encouraging the food processing industry in Queensland to recycle water include:

- recognition of the true cost of water and of the fact that reducing water use will lower production costs
- new water charging arrangements by local governments to recover water costs
- higher costs associated with operating and upgrading wastewater treatment plants to meet rising standards
- tighter government controls on the quality and quantity of wastewater discharge
- increasing awareness of the detrimental effects on the environment of excessive water use
- increasing pressure on limited water supplies.

The Queensland Water Recycling Strategy (QWRS)

The QWRS is a Queensland Government initiative aimed at encouraging the adoption of water recycling that is safe, environmentally sustainable and cost-effective. The strategy's aim is to develop the best and most effective ways to manage municipal, industrial and agricultural effluents and urban stormwater as a resource rather than as a waste .

The QWRS outlines a set of action plans that help promote sustainable water recycling in Queensland. These include amending existing laws to support water recycling, and developing new legislation to deal with water recycling issues, especially approval processes.

The strategy recognises the great potential for industry to reduce water use by internal recycling. The recycling of treated municipal effluent in industry is also seen as an area of great potential; however, its applicability to the food processing industry may be limited due to strict food hygiene standards.

The Queensland Environmental Protection Agency (EPA) has prepared guidelines for the safe use of recycled water, which will be released for public comment early in 2004. Once these draft guidelines have been accepted as government policy the department hopes to develop industry-specific codes of practice for the use of recycled water. The guidelines cover laws affecting water recycling in Queensland, planning a recycled water scheme, responsibilities in water recycling, general safeguards for use of recycled water, and recycled water safety plans. For more information about the Queensland Water Recycling Strategy and Guidelines visit the Queensland Environmental Protection Agency website www.epa.qld.gov.au/environmental_management/water/water_recycling_strategy/

Some guidelines that have also been developed at a national level by the National Water Quality Management Strategy (NWQMS) including:

- Guidelines for Sewage Systems — Use of Reclaimed Water (2000)
- Australian Guidelines for Urban Stormwater Management (2000)
- Guidelines for Sewage Systems — Effluent Management (1997)
- Effluent Management Guidelines — Dairy Processing Plants (1999)
- Effluent Management Guidelines — Wineries and Distilleries (1995).

3.9.1 Onsite water recycling and reuse

Often final rinse water is relatively clean and may be suitable for recycling or reuse within the plant.

Reuse and recycling of process water

There may be opportunities for recycling relatively clean water with minimal treatment. By modifying washing equipment to include a recovery tank to store final rinse water, for example, it may be possible to recycle the water for subsequent pre-rinses. It may also be possible to reuse process water for other plant operations such as cleaning, cooling or boiler make-up water.

Case studies

Reuse of container washer rinse water for cooling: beverage processor, Australia

Cola Coca Amatil in New South Wales made pipework modifications to capture container rinse water, which is now used in the evaporative cooling towers. The new system saves the company 6 ML annually, a saving of \$15 000 in wastewater charges. The payback period was less than six months.¹

Water recycling in vegetable washer: fresh salad processor, Australia

Harvest FreshCuts in Queensland modified its vegetable washing system to enable water to be internally recycled, and now saves \$22 300 in water and disposal costs annually. The payback was immediate.²

Counter-current washing and water reuse for cleaning: brewery, UK

Carlsberg-Tetley Burton recovers the final wash water used in cask washing for reuse up to four times in other stages of the washing process. Water is recovered after each use and is finally used to wash down the conveyor belt. The company has reduced external rinses from 16 300 kL/year to zero, pre-rinses from 7700 kL/year to zero and conveyor washing from 11 000 kL/year to zero.³

Water reuse in pasteuriser: brewery, Australia

The South Australian Brewing Company recycled water in its bottle and can pasteuriser and saved \$60 000 in fresh water consumption annually. The payback period was 10 months.⁴

1 Environment Australia 2003c

2 UNEP Working Group for Cleaner Production 2002b

3 Environment Australia 2003c

4 Envirowise 1996b

WATER AND WASTEWATER RECYCLING AND REUSE

In single-pass cooling systems water is circulated once through a piece of equipment and is then sent to drain. To remove the same heat load, single-pass systems use 40 times more water than a cooling tower operated at five cycles of concentration (Federal Energy Management Program 2003b). Typically single-pass cooling equipment includes ice machines, vacuum pumps, air compressors, air conditioners and hydraulic equipment. Single-pass cooling equipment can be modified to operate on a closed loop so that water is recirculated. Alternatively, another use may be found for discharged single-pass cooling water, such as boiler or cooling tower make-up water or irrigation.

Case studies

Closed loop circuit on compressor: fish processor, UK

Previously water from the skinning machine compressor in a fish processing plant ran to drain. By introducing a closed loop circuit with a chiller to maintain a consistent temperature, the company has been able to save \$61 000 annually in reduced water and effluent charges. Payback period was three years.¹

¹ Envirowise 1999c

Reuse of wastewater

Options to reuse wastewater will be dictated by HACCP quality controls and the need to meet food safety requirements.

Case studies

Recycled water system: brewery, Australia

Castlemaine Perkins in Queensland previously sent water used in the packaging process (package rinser, pasteuriser overflow and filler vacuum pumps) to trade waste. A recycled water system was installed to collect each grade of water and treat them separately by filtration and chemical treatment as required. The water was then used where appropriate as boiler make-up water, cooling tower water, and for irrigation and hose-down. It is estimated the system saved 30 000 kL of water and \$50 000 per year. The cost of implementation was \$220 000.¹

Improvement in wastewater quality and water reuse: snack food processor, Australia

The Smith's Snackfood Company in South Australia was generating wastewater containing 10% solids. Treating the wastewater was costing the company \$130 000 annually. In addition to this, the build-up of solids often caused flooding and consequently stopped production. By introducing hydrocyclones into the potato and corn lines, however, the company is now able to separate solids from the effluent using strong centrifugal forces. The cleaner water from the hydrocyclones is collected in holding tanks and recycled into the system. Waste disposal costs have fallen from \$144 per tonne to \$40 per tonne. The payback period was five weeks.²

Reuse of water from settling dam for initial washing of raw material: ginger processor, Australia

Buderim Ginger in Queensland sends its wastewater from its washing process to a settling pond. After the solids have settled, the water flows back to another dam that supplies water for the initial washing of the raw ginger. The company saves 19 ML annually — around 15% of the company's total water use. This represents a saving of \$16 500.³

¹ Castlemaine Perkins 2003.

² Environment Australia 2003g

³ UNEP Working Group for Cleaner Production 2003k

Plants that are required to use filters to treat water before processing may be able to recover some of the costs by recycling the backwash water used to clean the filters. Some backwashing processes incorporate air to further reduce the amount of water required.

Case studies

Water recovery and reuse by filtering backwash water: beverage processor, Australia

Coca Cola Amatil in New South Wales cleans 10 sand and carbon filters daily and then recycles the backwash water from the filtering process through a treatment plant for reuse in processing. The initiative has reduced trade waste discharge by 25% and saved the company a further \$100 000 in water charges.¹

Reuse of backwash water for make-up water: cordial, jams and toppings processor, Australia

Schweppes Cottee's reuses backwash water from its sand filters for cooling tower make-up water, boiler feed water and line lube water. The company saves \$8280 annually. The initiative involved installing collection tanks, piping and pumps, with a payback period of five months.²

¹ Environment Australia 2003c

² Environment Australia 2003a

3.9.2 Offsite reuse of wastewater

The nutrients contained in some kinds of effluent may be a useful resource. Options for the beneficial utilisation of wastewater include crop production, forestry, land rehabilitation and even aquaculture.

Crop and pasture production

The use of treated wastewater on crops may be a viable option for food-processing plants located in rural and semi-rural areas. Crops being cultivated using treated wastewater include grains such as sorghum and corn, and fast-growing varieties for hay production. The use of wastewater is regulated by the Queensland Environmental Protection Agency to protect the environment and ensure public safety.

Case studies

Irrigation of pasture with wastewater: tomato paste processor, Australia

Heinz Watties in Victoria treats all its wastewater in dams and then uses the treated water to irrigate dairy pasture.¹

Irrigation of pasture with wastewater: dairy processor, Australia

Bonlac Foods in Victoria (Darnum Plant) discharges its low-solids general factory wastewater and rinse water to a primary or secondary treatment system. For five months of the year treated water is irrigated onto pasture to optimise growth rates while maximising water utilisation and nutrient uptake.²

¹ Environment Australia 2002d

² Darnum Cleaner Production Initiative 2003

Forestry and land rehabilitation

The use of wastewater for forestry operations or land rehabilitation involves matching the nutrient needs of forest crops with nutrients that may be available in some kinds of food processing wastewater, such as nitrogen and phosphorus. A number of trial effluent plantations in Victoria have shown that eucalyptus and conifers can have very fast growth rates when irrigated with treated wastewater (Stackpole 2001).

Case study

Winery wastewater irrigates red gum plantation: winery, Australia

Berri Estates Winery in South Australia produces large quantities of wastewater from washing down the plant and its equipment, as well as a smaller volume of wash water from its distillation process which has a high COD level. The high COD content means that the wastewater produces an offensive odour when left to stand in evaporative lagoons. To resolve the problem, the company is now using the wastewater to grow a plantation of Murray River red gums. The establishment of the plantation is an economical and sustainable wastewater disposal alternative, which has eliminated odour problems while also producing a future timber resource for the company.¹

¹ Environment Australia 2001c

Aquaculture

While only in its infancy in Australia, the use of treated wastewater as a nutrient food supply for algae and fast-growing species such as duckweed is common throughout Asia. Duckweed can be fed to fish, poultry and cattle (Landesman 2001).

Case study

Wastewater to grow duckweed for stockfeed: biotechnology company, Australia

Bio Tech Waste Management (BTWM) is a privately-owned company in New South Wales which is utilising duckweed to cleanse wastewater, and is researching the use of the harvested biomass as a feed supplement for livestock including fish. The company has used wastewater from municipal sewage treatment works, abattoirs and food processing plants. The company has undertaken extensive trials at a piggery and a beef cattle feedlot. Data from these sites has shown that wastewater treated by the BTWM system meets NSW EPA guidelines for continuous irrigation or discharge into river systems.¹

¹ Bio Tech Waste Management 2003

Controlling the concentration of organic matter and bacterial numbers in recirculating flumes by dilution would require the addition of clean water at a variable but high replacement rate. Although this practice will greatly reduce wastewater volumes compared to single-use fluming systems, the resultant waste load will still be considerable. Waste generation and bacterial numbers can be more effectively controlled by counterflow reuse and chlorination of water. When fluming peaches, apples and other high-acid products, bacterial numbers can be controlled with minimal dilution by controlling the pH of flume waters to 4.0 or less.

EVAPORATOR WATER

One type of evaporator widely used to concentrate tomato and fruit juices, fish solubles, and other food products employs a barometric leg to create a vacuum in the unit in order to condense vapors emanating therefrom (figure IV-5). Cold water injected into the barometric leg condenses water vapor and volatile organics while absorbing the heat of vaporization. Since the exit temperature of the water is one of the parameters which determines the efficiency of operation, cold water injection rates are closely controlled.

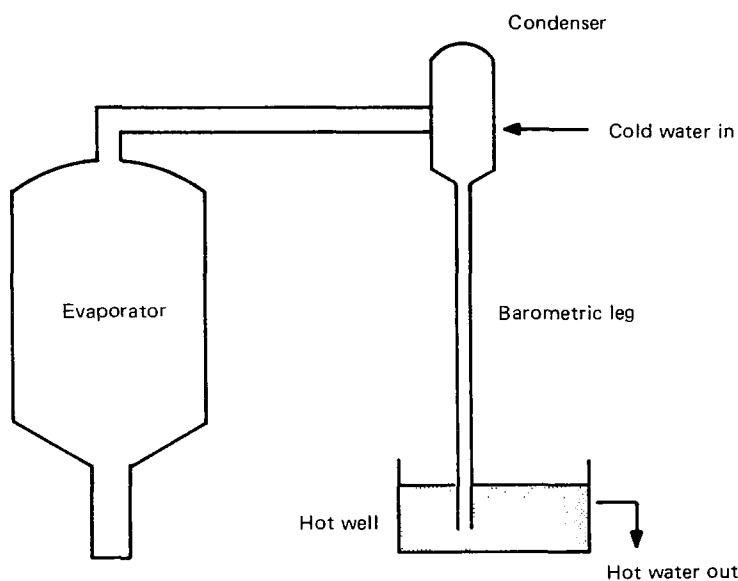

Figure IV-5. Barometric condenser water.

A multi-effect evaporator can consume a large quantity of water (in excess of 1,000 gpm). Because the effluent is warm (generally around 120°F) and may contain traces of organic matter, the water is often wasted. However, this water is suitable for reuse. Since the effluent volume is large, cooling and recycling offer the greatest potential for reducing the wastewater volume. Cooling towers are being advantageously used for this purpose. Although the thermodynamics will differ, the application is similar to the recovery of can cooling and freezer compressor waters. Fresh water additions may be required to control concentrations of minerals and organic matter. The resultant overflow from the system can be readily used elsewhere in the plant.

THE COUNTERFLOW WATER REUSE SYSTEM

Preparatory operations in food processing are designed to assure the delivery of clean, wholesome products to the final packaging operation. Water is used at various stages to separate and remove undesirable materials, such as leaves, soil, immature and overripe products, and bacterial

contaminants. To assure product cleanliness, water used in final washing and rinsing operations must be of highest sanitary quality, whereas water used in preceding operations need not necessarily meet such stringent sanitary requirements. This premise is the basis upon which counterflow water reuse systems have been developed.

Counterflow water systems are designed to minimize the quantity of water required to effectively prepare clean foods, thereby minimizing waste loads associated with food processing. Basically, most of the fresh water is used in the final operation, collected and reused in a previous operation, and recollected and reused in this manner one or more additional times. Since the water always passes counter to the flow of the product, the product comes into contact with subsequently cleaner water and is finally washed or rinsed with fresh water. Although the following discussion concerns counterflow reuse in pea processing, the principles may be applied to the processing of any commodity.

The sanitary condition of water is normally evaluated by measuring the bacterial population in the water. The sanitary condition of raw product is directly influenced by the bacteria count of the water with which it comes in contact. The condition of pea fluming waters was monitored during a study in which recirculation was compared to counterflow reuse with different chlorination practices.⁹ The results are summarized in table IV-4. The comparative bacteria counts clearly indicate the effectiveness of product cleansing by counterflow reuse of water.

Table IV-4.—Comparison of total numbers of bacteria in flume waters reused by recirculation and by counterflow methods, and comparison of the effect of varying the extent of chlorination in these waters⁹

Method of water reuse and extent of chlorination in each plant:				
Plant A — Water recirculated; in-plant chlorination only.				
Plant B — Counterflow reuse; no chlorination at any point.				
Plant C — Counterflow reuse; in-plant chlorination only.				
Plant D — Counterflow reuse; in-plant chlorination plus rechlorination.				
Use of water sampled	Plant	Bacteria count ^a per ml of water		
		High	Low	Average
Water used to flume peas from quality graders to inspection belts	A	23,000,000	27,000	4,729,000
	B	350,000	13,000	65,200
	C	14,500	2,300	6,300
	D	3,500	400	1,300
Water used to pump or flume peas from blanchers to quality graders	A	1,800,000,000	590,000	365,590,000
	B	1,900,000	77,000	611,000
	C	220,000	14,000	58,760
	D	21,000	700	6,250
Water used to flume peas from size graders to blanchers	A	78,000,000	98,500	15,752,000
	B	2,900,000	50,000	837,200
	C	190,000	10,000	40,140
	D	130,000	2,300	22,470
Water used to flume peas from washers to size graders	A	52,400,000	91,000	13,752,300
	B	11,000,000	350,000	1,780,000
	C	130,000	14,000	47,180
	D	140,000	3,500	31,610

^aBacteria counts represent the numbers of colonies growing on glucose-tryptone agar plates inoculated with unheated flume water and incubated for 48 hours at 86° F

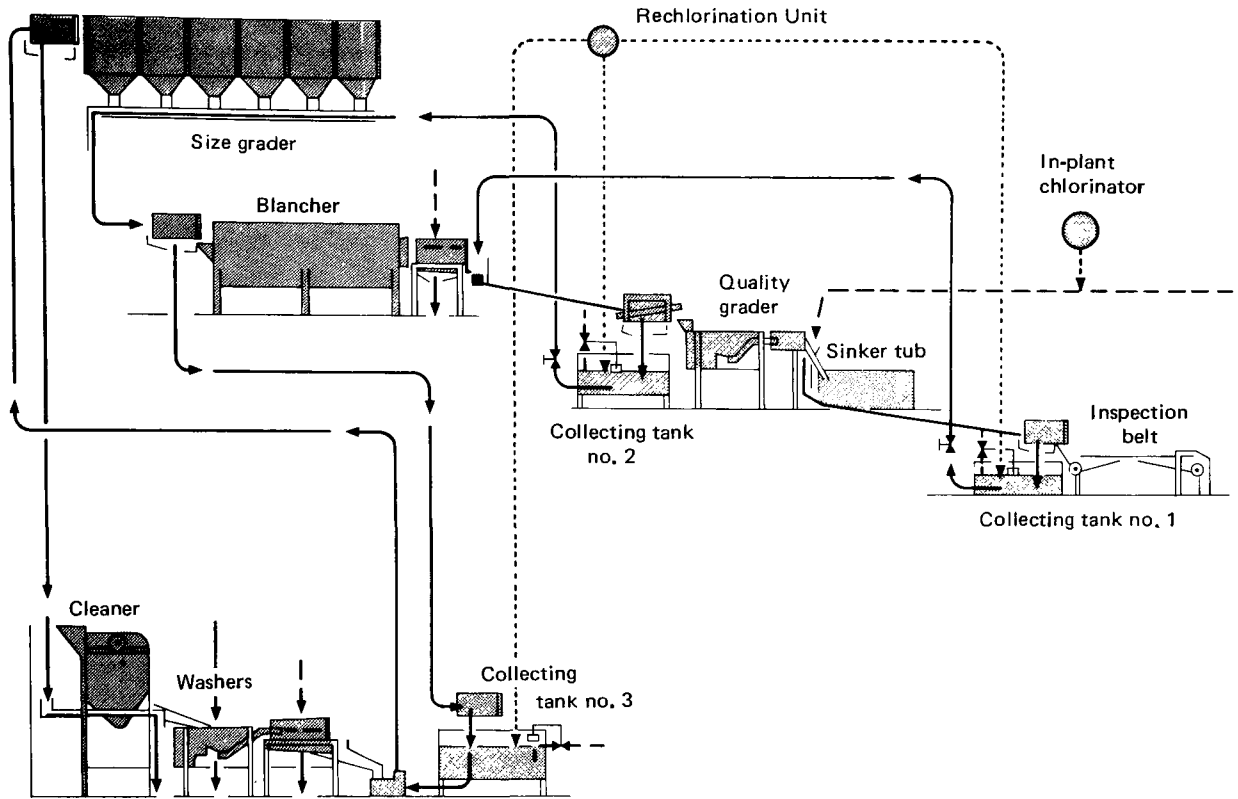

Figure IV-6. General plan for counterflow reuse of flume water in a pea cannery.

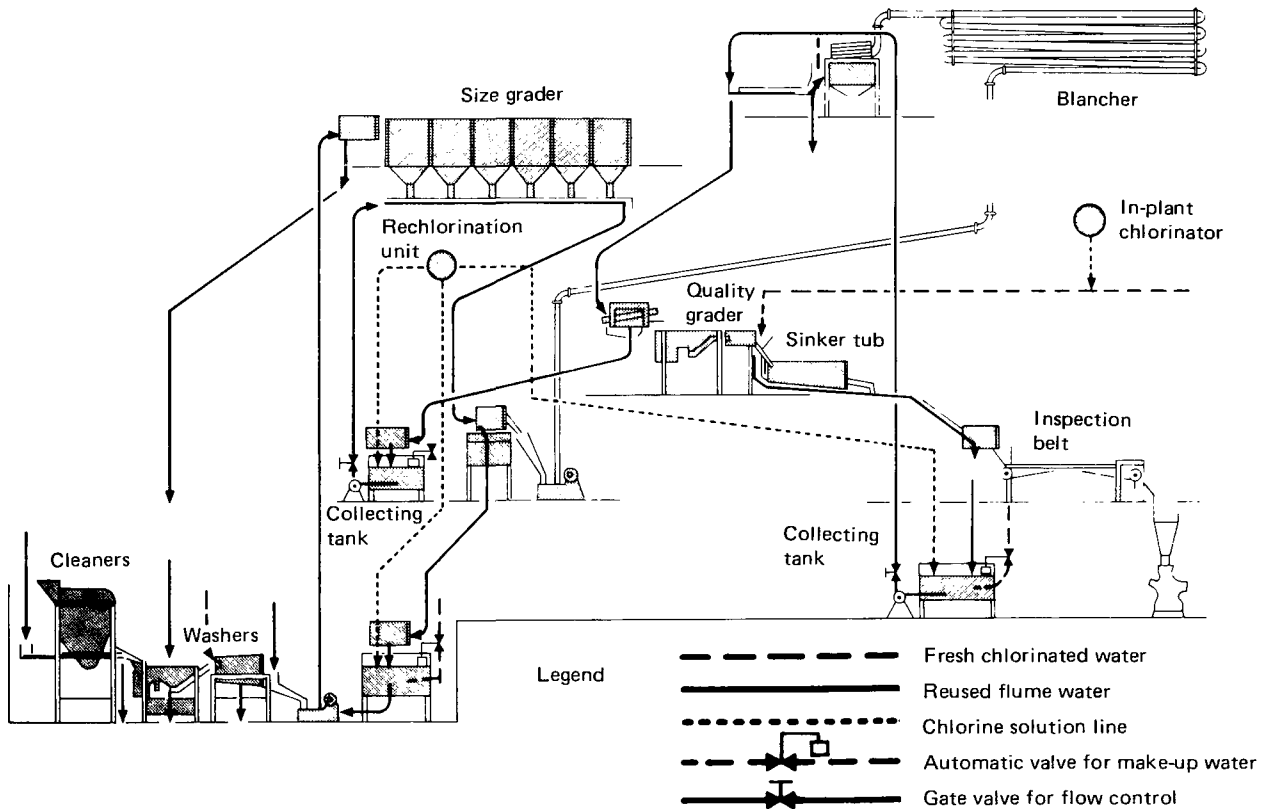

Figure IV-7. Plan of counterflow reuse system designed to eliminate undesirable features of flume system shown in figure IV-4.

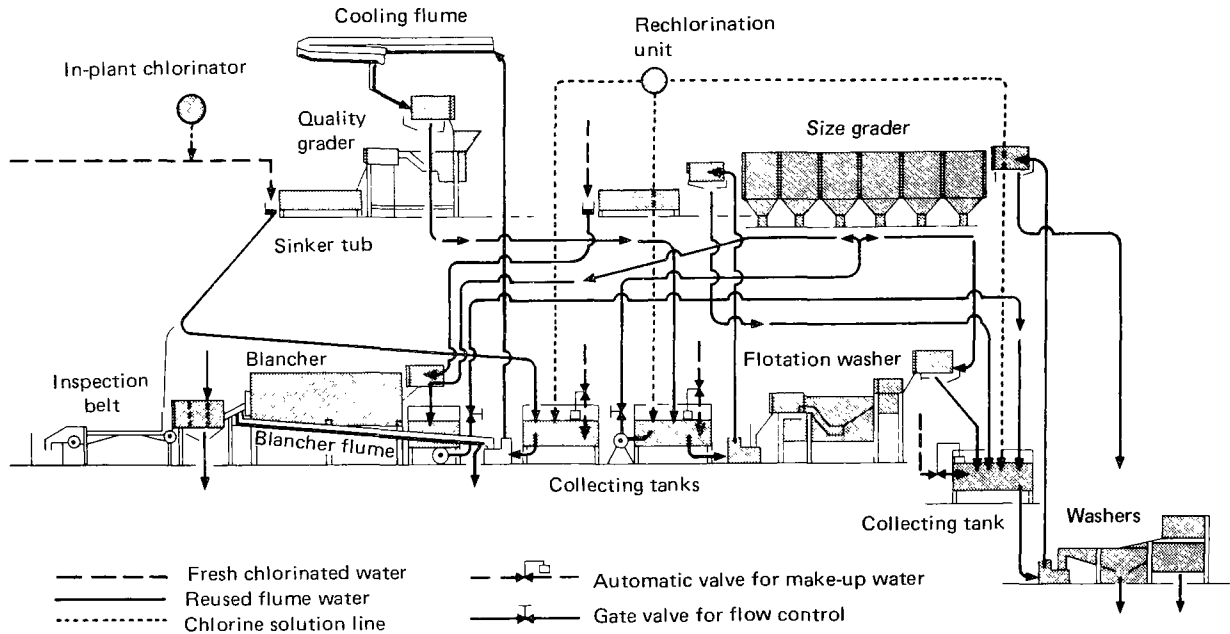

Figure IV-8. Plan for counterflow reuse of water in a pea cannery where line arrangements require extensive fluming operations

A FOUR-STAGE REUSE SYSTEM

A general plan for counterflow reuse of flume water in a pea cannery is shown in figure IV-6. In this plan most of the fresh water enters the system as flume water for conveying peas from the quality graders to the inspection belts. This is the final washing of the peas before they are filled into the cans. The water separated from the peas at the inspection belts is collected and used for the second time in fluming peas from the blanchers to the quality graders.

The water is used for the third time in fluming peas from the size graders to the blanchers, and for the fourth time to pump peas from the washers to the size graders. At the size graders, the water is separated from the peas by means of a reel. From this point it may be used in the first washing of the peas or may be diverted to flumes which remove wastes from beneath the cleaners. Figures IV-7 and IV-8 show counterflow reuse schemes for different arrangements of equipment. (Figure IV-7 may be compared with figure IV-4 to illustrate the differences between recirculation and counterflow reuse of water.) In each case rechlorination of the water is recommended after each use. As indicated by the results summarized in table IV-4, rechlorination will effectively reduce and control bacterial populations in reused water.

INSTALLATION OF COUNTERFLOW SYSTEMS

The amount of water which can be saved by a counterflow reuse system will depend primarily on the degree of balance obtained between the rate of fresh water addition to the system and the amount of water required to adequately carry out the different operations. If the system is to be water-saving, there must be no appreciable wastage of water other than that which may be required to maintain aesthetically acceptable conditions within the system. In order to obtain maximum benefits with minimum supervision, the system should include collection tanks, screens, and appropriate water valves.

Collection Tanks

After each use, the water should be collected in a tank from which it may be delivered by pump or gravity to the next operation. Ordinarily the water used in the same fluming operation on all of the canning lines should be brought into one collecting tank. For example, in figure IV-6, all of the water used to flume peas from quality graders to inspection belts would be collected in Tank No. 1. It is important that water from a later stage in the reuse system not be added to this tank. The tank should have sufficient capacity to contain, without overflowing, all of the water which would be delivered to it when all lines are in operation.

Screens for Reused Water

To prevent the accumulation of particulate matter in reused water, fine mesh screens should be provided at each collection tank. Removal of particulates will extend the reusability of reclaimed water. Dry systems to collect and transport the accumulated solids should be provided.

Automatic Valves for Fresh Water Make-Up

Fresh water lines, equipped with float-controlled valves, should be provided at each collecting tank. These valves will eliminate the possibility of the tank becoming empty, thereby protecting the pump and assuring that an adequate supply of water is available for the subsequent operation.

Control of Flow Rates

Minimization of water usage by the counterflow reuse method depends entirely upon maintaining balances between the several component subsystems. Water withdrawn from any collection tank must not exceed that volume which is required by the next operation. In addition, the withdrawal rate from any collection tank should not greatly exceed the previously used water supply rate.

Careful planning is a definite prerequisite to successful implementation of counterflow reuse systems. Control of such systems will be facilitated by the use of variable speed pumps for adjusting all flow rates. Alternately, gate valves, installed in the lines immediately after the pumps, can be used to regulate the water withdrawal rate from each tank to correspond to the water requirement in the next operation. In either case, periodic adjustments may be required to assure maintenance of appropriate balances and maximum efficiencies.

Cooling and Washing Requirements

In the usual arrangement of the counterflow system for peas, the second use of water is for fluming or pumping peas from blanchers to quality graders. This fluming operation requires more careful attention than the other. The peas are discharged from blanchers at an average temperature of 200°F and are covered with varying amounts of foam and blanch water high in organic solids. In some cases the blanchers may be contaminated with thermophilic flat-sour bacteria, the spores of which will be on the peas. If these peas are discharged into the flume while still hot, the sanitation of the third and fourth stages of the reuse system may be greatly impaired. Warm water will favor rapid microbial growth which can cause excessive slime growth on equipment.

Of more serious consequence, however, is the increased potential for flat-sour spoilage in canned peas. Studies have shown that blanched peas not previously cooled before entering the flumes to the quality grader may reach the grader with a temperature still above 100°F. Elevated temperature in water which has a high concentration of organic matter will be favorable to the growth of thermophilic bacteria in the flumes. Furthermore, failure to adequately wash blanched peas can result in an accumulation of thermophilic spores in the quality grader brine.

Impairment of water quality due to factors attributable to blanchers can be prevented or greatly minimized by cooling and washing blanched vegetables in a separate operation. Equipment which can be used for this purpose (listed in the order of preference) include air coolers, vibrating screens with overhead sprays, reel washers and hydrocooling flumes. Sprays used with vibrating screens or reel washers should be supplied with cold, chlorinated water. Since the volume of water used by these units is relatively small, the wash water can be wasted without contributing significantly to the total plant effluent. Discharging of the wash water will enable more extensive reuse of the large volume of water in the counterflow system by minimizing heat input and by preventing excessive amounts of organic matter and bacteria from accumulating within the reuse system.

Water Saved

Under average conditions, it has been estimated that the installation of a counterflow reuse system will reduce the total water consumption by approximately 50 per cent of the volume which would otherwise be used if fresh water is used in all operations. However, the amount of water which can be saved by installing a counterflow system depends upon the unit operations within each plant. Estimations of potential water savings and waste load reductions can be made by surveying the processing plant and monitoring each wastewater flow.

SPECIAL WATER REUSE SYSTEMS

Variations in plant layouts, processing operations, types of equipment, and varying urgencies to conserve water and/or reduce waste loads, not to exclude variable waste characteristics, are but a few of the many reasons that detailed discussion of specific water reuse systems are of limited value. Instead, coverage of general principles which can be adapted to a variety of situations have been attempted in the preceding sections. However, some unique situations offer potentially widespread applications as solutions to common problems. For this reason, the following special systems are described.

“TRIPLE DUTY” WATER REUSE SYSTEM

An advanced type of water reuse system in a specialty foods plant has recently been reported.¹⁰ This system has been designed not only to conserve water, but also to conserve heat energy. As depicted in figure IV-9, the system consists of two parallel closed loops and a third open-ended leg. The main feature of the closed loop circuits is the sterilization tank. Make-up water added to the system at this tank is recovered air compressor cooling water and condensate from cereal drum dryers and building heaters. The water is treated with ozone, pumped through a vertical cartridge-type filter heated to 190°F in a shell-and-tube heat-exchanger, and supplied to the two closed loop systems.

Water in the first loop is used to wash empty jars. The wash water is collected in a sump, pumped through a filter and returned to the sterilizing tank. In the second loop, the water is used to fill retorts. Effluent from the retorts is collected in two separate sumps. Water with a temperature above 150°F is collected in one sump, while water below 150°F is collected in the other. The hot water is filtered and returned to the sterilization tank, thereby completing the second circuit. By segregating and recycling only the hot water, less energy is required to reheat water from the sterilization tank, thus resulting in a conservation of heat and fuel. Water below 150°F from the retorts is used in the final leg of the system. This water is used for flushing gutters and cleaning floors in processing areas and is discharged thereafter to waste.

SEDIMENTATION – CARBON FILTRATION WATER RECOVERY SYSTEM

A treatment and recovery system was designed to remove suspended and dissolved solids and to reduce the bacterial load from green bean processing wastewater.¹¹ A simplified diagram of the

system is shown in figure IV-10. The special feature of the water recovery operation is the sedimentation and carbon filtration treatment system which clarifies the used water sufficiently for recycling through the canning operations.

The Water System

The water reservoir may be considered the starting point of the cycle. It is divided into two compartments, one containing 40,000 gallons of fresh water and the other a 20,000-gallon mixture of recovered water and fresh water. In this way, a supply of fresh water is readily available in the event of system malfunction. Air is bubbled through the recovered water compartment to increase dissolved oxygen. Chlorine in the form of hypochlorite is added periodically to the reservoir.

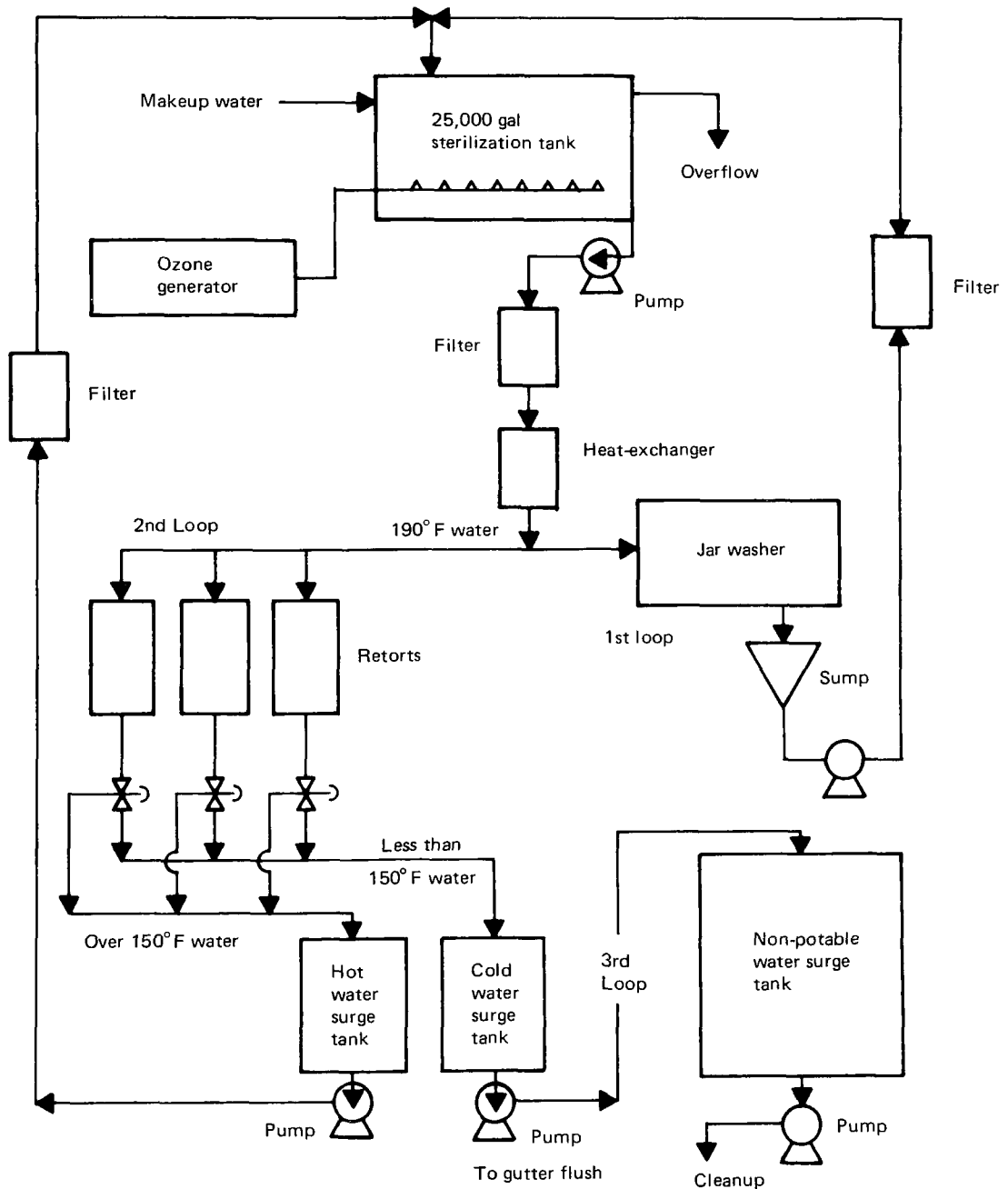

Figure IV-9. Triple duty water reuse system.

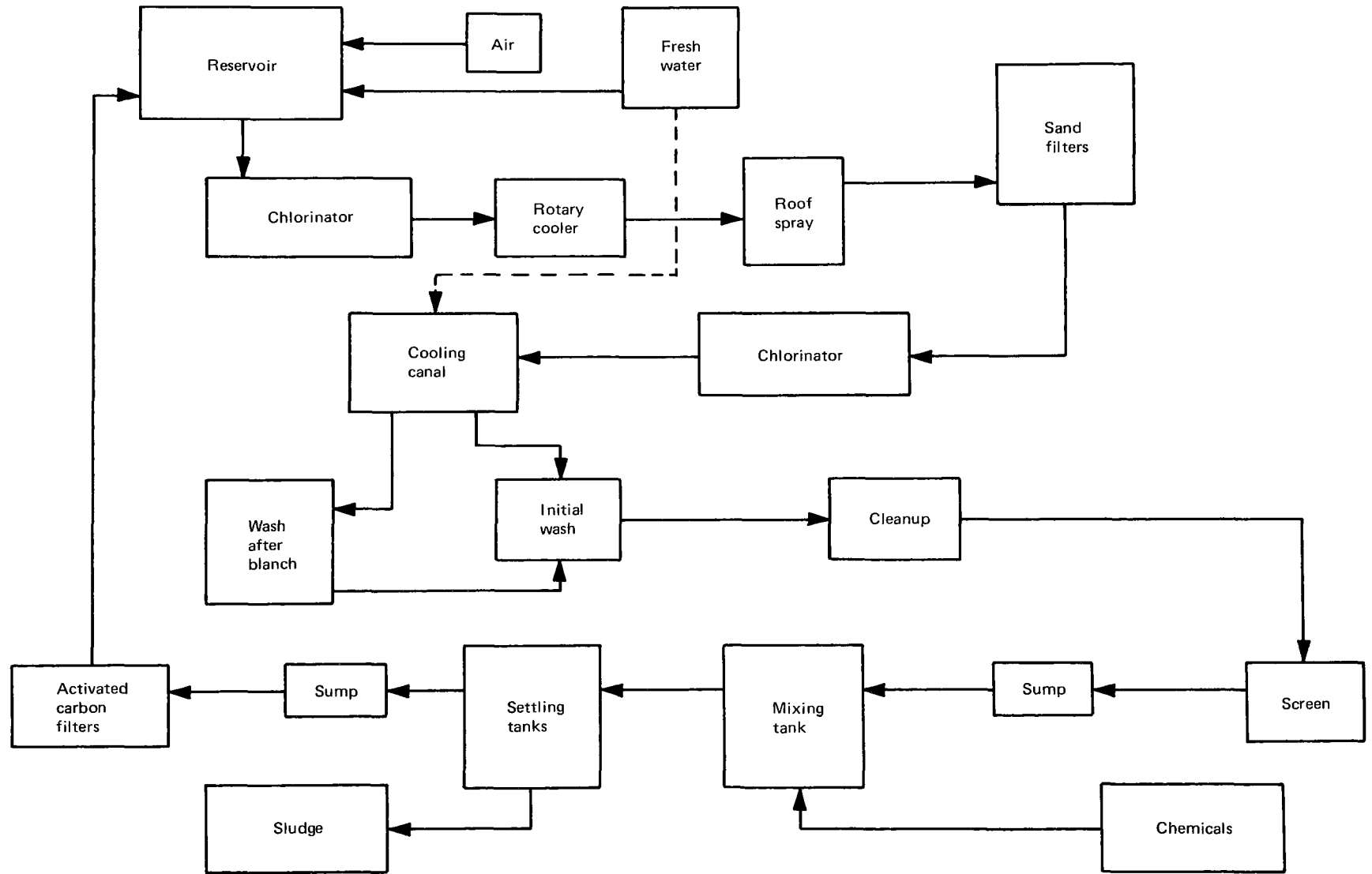

Figure IV-10. Diagram of charcoal filtration water recovery system.

Water is pumped from the recovered water compartment to the first chlorinator, where sufficient chlorine is added to give 1 ppm free residual. From the chlorinator, some water is sent to the rotary can cooler and the remainder is sent to the can cooling canal. The water from the rotary cooler is sprayed cooled, filtered through sand, chlorinated, and added to the can cooling canal. The water overflow from the cooling canal is used in three ways: for product washing after blanching, for initial product washing, and in the plant drains to carry out solid wastes. Water used for both product washing operations is combined with the plant drain water and channeled to the treatment area for screening. Particles larger than 1/2 inch are removed by passing the wastewater stream through a mesh belt conveyor. Waste particles smaller than 1/2 inch are removed by a 48-mesh, 60° tangential screen. The screened wastewater is divided into three portions. One portion is pumped directly into the plant to flush the floor drains. Another portion is piped into the water recovery system. The remainder of the liquid waste is discharged.

The Treatment System

The recovery system consists of coagulation, sedimentation, and filtration treatments. When operating properly, the system is designed to remove all traces of suspended matter, including colloidal particles. Under ideal conditions, the filter effluent will be almost free of bacteria. Caustic soda, aluminum sulfate, and a polyelectrolyte (flocculent aid) are added to the screened wastewater in a flash mixing tank. After a 3-minute detention period, the mixture is delivered to two flocculating tanks, each of which provides a 10-minute detention. Air is injected into the tanks to provide agitation and facilitate flocculation. Flocculated solids are removed as a sludge from the settling tank and are discharged to a lagoon. The clarified water is filtered at the rate of 50 gpm through a 5-foot bed of activated carbon and is returned to the water reservoir.

Treatment Results

The reduction in fresh water consumption achieved with the reuse treatment system is shown in table IV-5. The recovery system resulted in an 18.4% reduction in fresh water consumption by the canning plant during the first year and a 25.4% reduction during the second year. The hydraulic loading on the waste disposal system was thus reduced by a corresponding proportion.

It should be emphasized that the data are derived from wastewater resulting from a single product operation, green bean canning. This water recovery system works well for this plant and for this particular product. Water from multi-product operations may be more difficult to treat; each system should be considered individually. However, the results indicate that wastewater reclamation and reuse is feasible without undue risk of canned product spoilage.

pH CONTROL OF RECIRCULATED WATER

The use of hydraulic conveying systems by food processors is extensive in view of the advantages which such systems offer. These advantages are as follows: water is a convenient and efficient transport medium; hydraulic systems are generally more compact than dry conveyors; little attention is required for operation of hydraulic systems; and maintenance of product appearance is enhanced by the gentle handling imparted by water. To maintain acceptable aesthetic and sanitary conditions within hydraulic conveying systems, a large volume of water is generally added continuously, thereby resulting in a continuous overflow from the system. By dilution in this manner, food particles and product juices which are washed or leached from the conveyed commodity are maintained at low concentrations within the system; microbial populations are likewise minimized. Where hydraulic conveying systems are used, the organic matter which is continuously discharged from each system is a major source of the total organic load associated with the processing operations. The water discharged from each system is a major contributor to the total hydraulic load of the plant effluent. Measures to reduce the waste loads from hydraulic conveying systems must include consideration of the sanitary condition of the water within the systems.

Table IV-5.—Effect of water recovery system on water usage in canning green beans¹⁰

Date	Gals/case fresh water only	Gals/case using recovered water	Percent decrease
8-7-67	22.9	16.4	28.4
8-9-67	26.5	18.2	31.3
8-11-67	32.9	22.2	32.5
8-29-67	27.2	20.3	25.4
8-31-67	24.3	19.3	20.6
Average	26.8	19.3	28.0
1967 Season ^a	25.5	20.8	18.4
1968 Season ^a	20.8	15.8	25.4

^aFor periods when recovery system was used.

It is well established that the pH of water affects the growth rate of microorganisms. The optimum pH for most bacteria is in the neutral range (pH 6.5 to 7.5). As the pH of the medium is made more acidic or more basic, microbial growth rates decline. Under very acidic or very basic conditions, bacteriostatic effects are evidenced. The growth responses observed in a simulated flume system are graphically illustrated in figure IV-11.¹² These results are the basis for the use of pH control to maintain the sanitary condition of recirculated water. This control methodology is especially well suited for systems conveying naturally acid products (such as tree fruits and tomatoes) and may be used for potatoes and other vegetables.

EXPERIMENTAL RESULTS

A demonstration project was conducted to confirm on a commercial scale the findings of the earlier laboratory study.¹³ Two identical pumping systems were used for this investigation. In each of these systems, cling peach halves were discharged into tanks and pumped to the filling operation. The peaches were dewatered and delivered to can fillers. The water was then returned to surge tanks for recycling. Fresh water could be added to each system as required. In one system, pH control capabilities were provided, as graphically depicted in figure IV-12. Citric acid, an edible acid which naturally occurs in fruits and tomatoes, was used to acidify and maintain the water at pH 4.0. The parameters monitored for each system included the volume of water consumed, bacterial counts on representative samples, temperature, pH and BOD. The quantity of acid used in the test system was also measured.

The amount of fresh water added to each system and the quantity of BOD generated by each are summarized in table IV-6. In this case, the acidified pumping system used only 25 percent as much fresh water and generated only 70 percent as much BOD as did the unacidified control system.

The quantity of citric acid required to maintain pH 4 within the system will be dictated by the rate of fresh water addition, as well as the pH and buffering capacity of the raw water and commodity being transported. Citric acid consumption in relation to the volume of water added to the system (averaged over several days of operation under the test conditions described) is summarized in table IV-7.

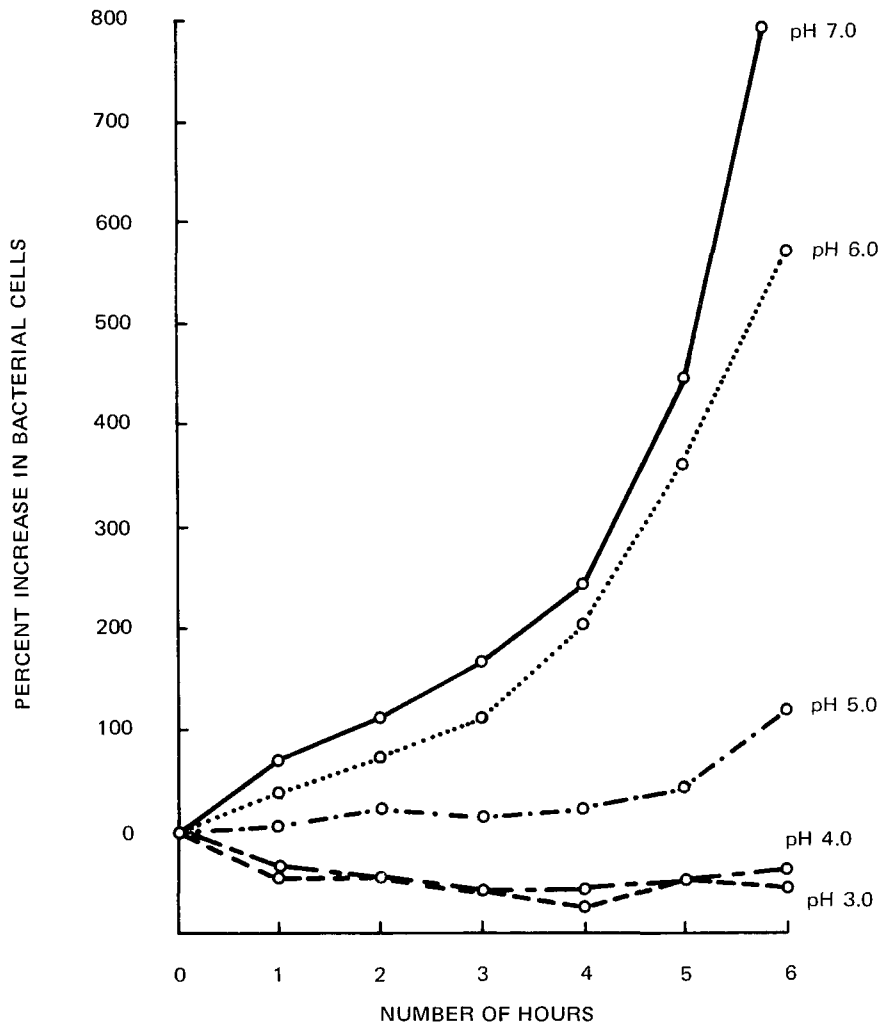

Figure IV-11. Effect of pH control on the growth of bacterial cells.¹²

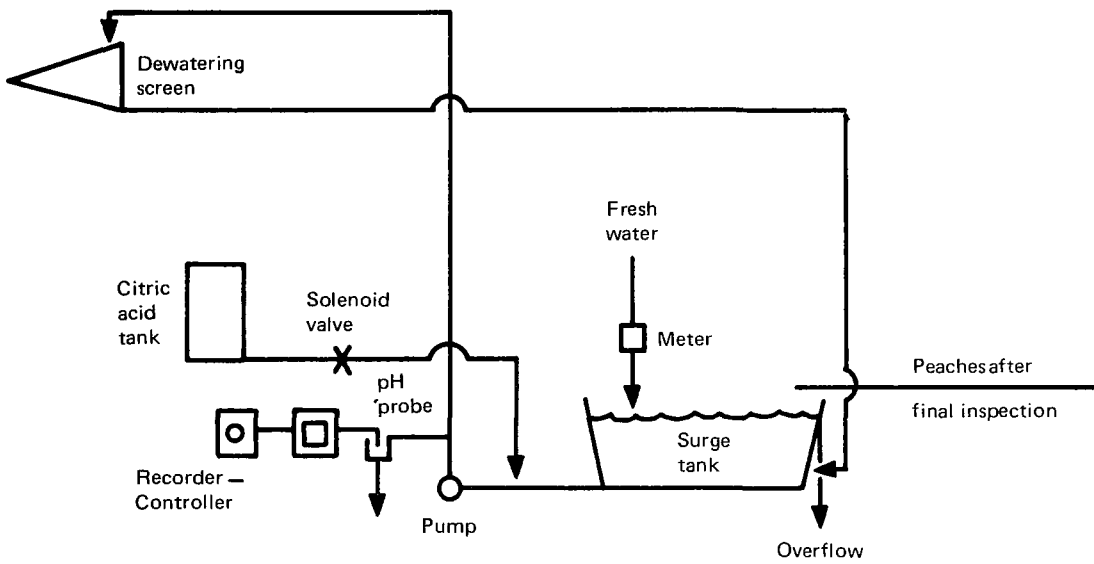

Figure IV-12. pH control system.¹³

Table IV-6.—*Characteristics of fruit pumping water
(24 hours of operation)*

Measurement	Acidified	Control
Water make-up, gpm	5	20
Total water volume used, gallons	6,720	26,520
Average BOD, ppm	2,034	742
Total BOD discharged, pounds	118	170

Table IV-7.—*Citric acid consumption at various fresh water flow rates*

Flow in gallons per hour	Lbs citric acid added per hour
65	2.1
160	2.3
220	2.4
330	2.8
420	3.1
560	3.2
700	3.6

Results of tests performed on samples collected from the two systems are summarized in table IV-8. The relative bacterial count was obtained by reducing the total plate count to a common denominator. Results are reported for samples taken at 2-hour intervals over a 24-hour period. Almost without exception, the bacterial count in the acidified system was equal to or lower than the count in the control system.

Use of the pH control system resulted in reduced consumption of water required to maintain sanitary conditions in the recirculated water system. The acidified system was operated at the make-up rate equal to 25 percent of the control system. The second principal benefit of using less water is the resultant reduction in the volume of effluent. Using the current water charges in one California community, the reduced intake of fresh water would pay for the citric acid used in controlling the pH of the water. A water savings of 20,000 gallons per day would reduce the water bill by \$6.00. Using an average of 2.5 pounds of citric acid per hour at 10 cents per pound, the cost of the acid would be equal to the savings in the smaller volume of water used. There would be a net savings in sewer service charges for the reduction in the volume of effluent and pounds of BOD discharged.

The pH control system was operated continuously for only 24-hour periods. It is very possible that even longer periods of operation could be used and the consumption of fresh water further reduced. This would result in even greater savings in water and citric acid, with fewer pounds of BOD discharged. Had recirculation of the acidified water extended beyond 24 hours, there may have been an even greater increase in the soluble solids content of the recycled water. In this case, the osmotic exchange between product and water would decrease. This would mean less leaching from the product and a further reduction in the BOD load of the recycled system.

Fresh water addition into the system should be controlled by a properly installed float-actuated valve. If continuous addition of water is deemed desirable, the rate of addition should be minimal. In some situations, product fragments and other debris may tend to accumulate within the system. A screening device incorporated into the return water line will facilitate removal of such objectionable materials and extend the usability of the recirculated water.

Table IV-8.—Comparison of control & test systems

Time of sampling	Total count $\times 10^{10}$		pH		Temp. °F	
	Test system	Control system	Test system	Control system	Test system	Control system
6 a.m.	0.5	6	4.4	7.6	67	67
8 a.m.	63	138	4.1	7.2	72	70
10 a.m.	72	226	3.9	7.3	75	72
12 noon	39	106	3.8	7.4	72	70
2 p.m.	84	137	3.9	7.4	74	70
4 p.m.	61	111	4.0	7.4	76	72
6 p.m.	97	60	3.9	7.7	76	70
8 p.m.	41	82	3.8	7.4	75	71
10 p.m.	67	80	3.9	7.2	76	72
12 midnight	13	22	3.8	7.5	75	69
2 a.m.	2	59	3.8	7.4	74	69
4 a.m.	17	9	3.8	7.3	75	71

Foaming may be encountered in recycled systems as a result of the accumulation of soluble organic matter. This can be controlled by the addition of an approved anti-foam substance or by the installation of fine mist sprays in the area where the foam accumulates.

Although microbial growth can be effectively controlled in an acidified system, it is important to insure that the system does contain “dead ends” or blind spots which may provide favorable harbors for microorganisms.

- For pre-coat filters, choose an air “bumping” system, where feasible, to further reduce water use.

Refer to Table 7.51 in Section 7.3.8 for a summary of selection factors to consider for new or replacement pool filtration systems.

Water Savings – Filtration

The water needed for backwash and filter cartridge cleaning varies significantly based upon the type of filter system used. For smaller pools, cartridge filters use significantly less water than sand and DE filters; for larger pools, industrial type filters use the least. Table 7.48 shows that the most efficient filters use between 68 and 98 percent less water than conventional sand filters.

Table 7.48 - Comparison of Backwash and Cartridge Water Use per Pool per Year for Different Types of Filters

	Estimated Use in Gallons Per Pool Per Year				Maximum Possible Reduction
	Sand	DE	Cartridge	Industrial	
Hot Tub	935	468	300		68%
Above-ground	4,189	1,466	800		81%
In-ground	8,415	2,945	1,200		86%
Apartment	22,440	7,480	2,500		89%
Hotel/Motel	29,920	9,350	3,600	5,000	88%
Public	166,222	41,556		9,000	95%
Olympic	959,568	239,892		17,000	98%

7.3.8 Water Treatment

Overview

Water treatment is used in many commercial operations, including food services, laundries, laboratories, pharmacies, car washes, and food service establishments. Industrial water treatment technologies are commonplace but often require technologies not found in commercial settings. The type of treatment depends on the application and the required water purity for the intended use. Treatment techniques and levels range from simple cartridge filters and water softeners to the production of ultrapure water for medical, laboratory, and microelectronics operations. Table 7.49 summarizes common treatment systems.

Table 7.49 - Treatment Technologies

Type of Treatment		Brief Description of Application
1	Sediment Filtration & Removal	Removes particulate matter and some bacteria
2	Coagulation & Sedimentation	Removes sediment or precipitates formed in industrial operations and metal finishing operations
3	Plate and Frame Filtration	Filters sediment and precipitates
4	Softening	Removes magnesium and calcium hardness
5	Ion exchange	Removes cations and anions
6	Distillation	Removes cations and anions
7	Membrane technology	Reverse osmosis and nanofiltration removes pyrogens and cations and anions while microfiltration and nanofiltration remove very small particulates and colloidal material
8	Disinfection	Kills bacteria and deactivated viruses
9	Carbon Absorption	Removes organics and some metals

The first three treatment technologies entail filtrations. The next two remove salts and other dissolved minerals including hardness. Membrane technologies include (1) microfiltration, (2) ultra filtration, (3) nanofiltration, and (4) reverse osmosis (RO). The last two technologies, disinfection and carbon absorption, represent processes also commonly used by the CII sector.

To illustrate the application of these treatment technologies, Figure 7.64 shows the types of filtration processes and the types of constituents that the filtration process will remove.

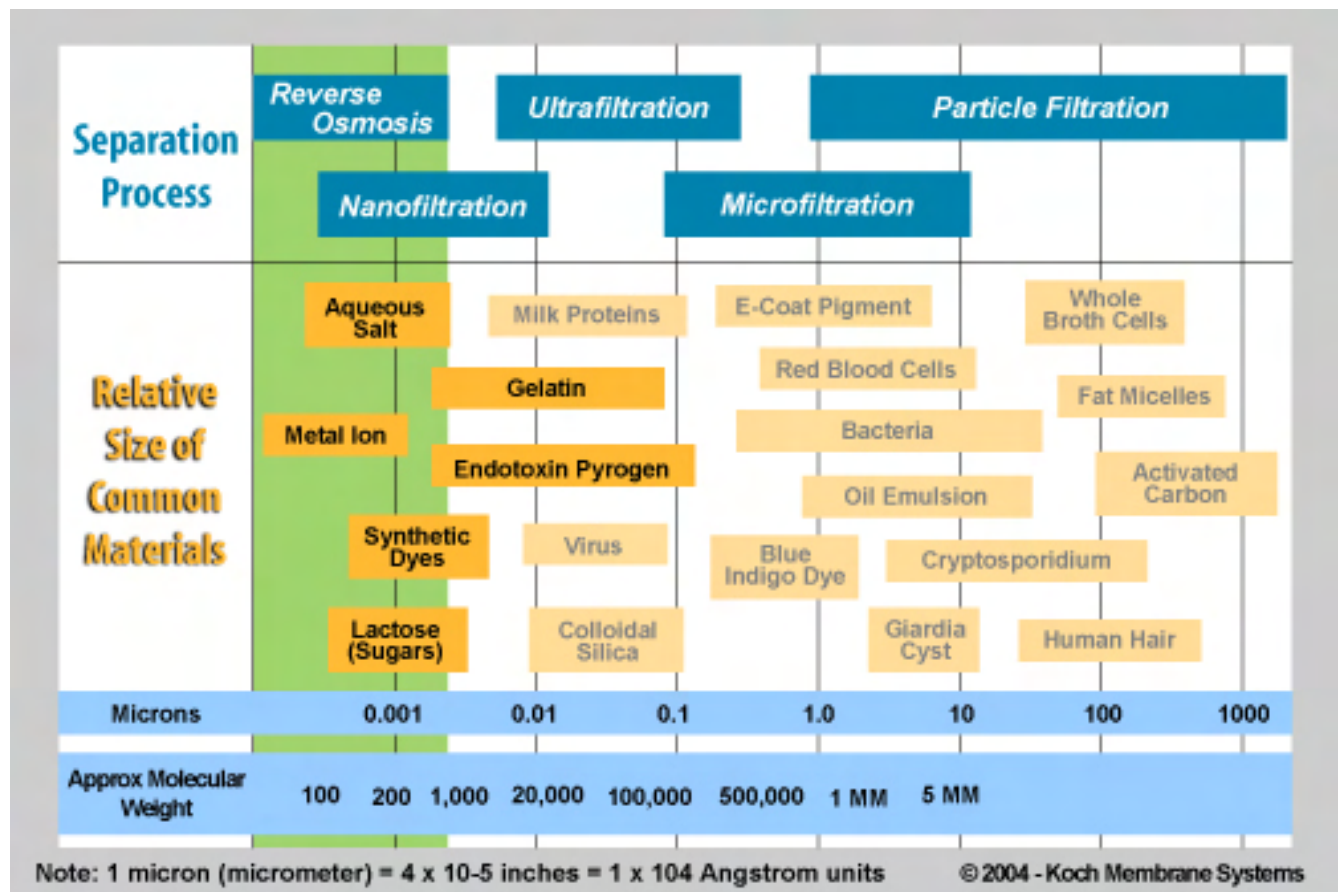

Source: http://www.kochmembrane.com/sep_ro.html

Figure 7.65 - Removal of Particulates and Salts

The ultimate use of the water determines the level of water treatment needed. For potable water, removal of particulates to the 20-micron level is often sufficient, as long as the water is disinfected and the level of salts is not too high. For many industrial processes and for low pressure boiler feed, it is often necessary to remove hardness. For high-pressure boilers and many industrial operations, the level of needed purity can only be obtained by reverse osmosis. For microelectronics manufacturing and many pharmaceutical and laboratory operations “ultra-pure” water (UPW) is required. Additionally, removing organic material is also a common practice.

Treatment systems also provide the ability to use water that would be discharged as wastewater. This water is reusable either directly in the facility where it was generated or by municipal water recycling. The California Building Standards Commission (CBSC) is currently working on new standards for graywater and intends to include other onsite sources. The process is in the beginning stages.

The following section describes the major technologies used to treat water in the CII sectors.

7.3.8.1 Sediment Filtration and Removal Processes (Non-Membrane)

Overview – Sediment Filtration/Removal

Removing sediment, suspended solids, and other particulate materials from water is one of the most basic forms of water treatment. Many technologies have been developed over the years to accomplish this task. One of the most common processes is filtration. Sand and zeolite, precoat, cartridge, and bag filters are used in many commercial, institutional, and industrial processes. Another sediment removal technology is the use of centrifugal force.

Types of Equipment – Sediment Filtration/Removal

Sand and Zeolite

Sand and zeolite filters use a bed of sand (Figure 7.66) or zeolite to filter the water. Water is pumped into the top of the filter, where it passes through the sand bed, and particulates are captured. As it operates, a layer of material filtered out



Figure 7.66 - Typical Sand Filter

of the water builds up on the top of the sand bed. When the pressure difference from the top of the bed to the bottom of the bed exceeds 8-10 pounds per square inch, the filter should be backwashed. Special valves allow this to happen. The water moves from the bottom of the filter up through the filter material to the top, discharging the accumulated dirt on top of the filter. When the water in a sight glass appears clear, the dirt has been removed. Larger systems can use horizontal filters, which are simple tanks on their sides.

Precoat Filters

Precoat filters include conventional diatomaceous earth²²⁴ (DE), cellulose,²²⁵ or perlite²²⁶ filters, as well as regenerative filters that reuse the filter media. These

²²⁴ Diatomaceous earth is a white powder made from the "skeletons" of small aquatic plants in the algae family called diatoms. It is inert, but breathing the powder can be harmful since the skeletons are made up of silica materials. Residential and commercial filters typically use either DE or perlite media. In recent years, many wastewater utilities have placed bans on the discharge of diatomaceous earth to sanitary sewers since it tends to settle out and clog sewer lines. Settling tanks and bag filters are often required to remove the DE before the water can be discharged. The DE can either be disposed of in the trash or used as a soil amendment. DE has a bulk density of 19 pounds to 22 pounds per cubic foot.

²²⁵ Cellulose is made from plant fibers. It is not widely used for pools, but is used in some food and beverage operations.

²²⁶ Perlite is made from a silicon-based material found in volcanic deposits. When heated, it expands to form a very light weight, chemically inert material that is used for filtration, as a soil conditioner, and insulation. Because it is so light weight, it tends to float on water when dry. It does not have the strong tendency to settle out in sewer lines that DE does. For this reason, many wastewater utilities have allowed filter backwash water from perlite coated filters to be discharged to sewers. Many utilities collect the backwash water and use the perlite as a soil amendment. Perlite has a bulk density of two to eight pounds per cubic foot.

filters remove particles down to five microns in size, while sand and cartridge filters work in the 10- to 40-micron removal range.²²⁷ Refer to Section 7.3.7.5 for a detailed discussion on Precoat Filters.

Cartridge Filters

Cartridge filters use pleated filter elements made from paper or other material. Most use washable filter elements with a range of filter elements, typically in the range of 1.0 to 20.0 micron particulate removal (Figure 7.67).

In the past, disposable filter elements were used, with filter replacement taking place each time the pressure across the element built up. Re-usable cartridges are now available. Because these filters do not need to be backwashed, they are the most water-efficient type available for all but the largest systems and are finding wide acceptance in the residential and smaller apartment pool market. Their water efficiency has led some local governments to encourage their use.

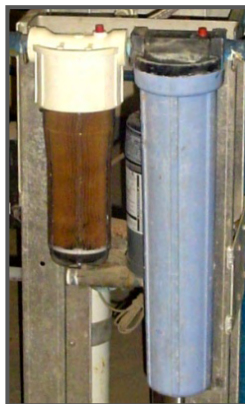

Figure 7.67 - Small Cartridge Filters

Bag Filters

As the name implies, bag filters use a filter cloth housed in a cylinder. Bags are generally washable and can be used many times as long as the substance removed does not stick to the bag. Bags of various micron sizes can be purchased. In some cases fine metal mesh can be used instead of cloth.

Cyclone Separator

Cyclone Separators (hydrocyclones) and centrifuges remove larger particles and sludge from water by centrifugal force. These separators are often used to remove particulates of larger sizes, although some manufacturers report that their equipment can remove particulates as small as 20 to 30 microns. When used with a bag filter to filter the purge stream, they are capable of recovering almost all of the "purge water" from the separator (Figure 7.68). Even if a bag filter is not used, the purge stream can be less than the backwash water requirements of a sand filter according to some manufacturers (www.therodgroup.co.uk/cyclone-filtration-how-it-works.asp)



Figure 7.68 - Cyclone Separator with Bag Filter

227

Selection Considerations

All of the above processes will remove particulates and sediment from water. The choice depends on the type of particulates that need to be removed and a number of operational considerations. Table 7.50 summarizes these filter options.

Table 7.50 - Non-Membrane Particulate Removal Systems

Type of Filter	Particle Removal range (Microns)	Requires Replacement Elements
Cyclone Separators	> 20	No
Sand Filters	> 20	No
Cartridge Filters	1.0 to 20	Yes
Precoat Filters	>5.0	No
Bag Filters	1.0 to 20	Yes

Cyclone separators are inexpensive and low cost to operate. Their applicability includes areas where cooling tower side stream treatment or industrial continuous solid - liquid separation is needed. They also find use for raw surface water intakes where larger sediment must be removed. Since post filtration of the purge water with the sediments is possible, they can be extremely water efficient. Their application must be evaluated on a case-by-case basis.

For finer filtration, filters are commonly used. The selection and operation of these filters depends on the type of sediment to be removed and the end use of the water. Filtration systems for commercial operations can range from a few hundred dollars to tens of thousands of dollars. For large industrial operations, the cost can be in the \$100,000's depending on volume of water treated and design. Sand filters tend to be more expensive than coated media and cartridge filters. To help understand some of the cost consideration, Table 7.51 shows selection factors for swimming pools. These factors are generally applicable across commercial and institutional lines.

Table 7.51 - Filter Selection Factors for Pool Filters*

	Sand	Coated Media	Cartridge
Frequency of Cleaning	Every week	4-8 weeks	Depends on unit
When to clean (<i>Difference in pressure across filter</i>)	5-10 psi	8-10 psi	8-10 psi
How cleaned	Backwash	Backwash ^(a)	Take apart & wash with hose
Filtration (<i>microns</i>)	20-40	5	10 (can vary on cartridge)
Time between media replacement	3-6 years	Every recoat	2-4 years depending on filter
Cost of media	\$0.50 to \$1.00/lb	\$0.15 -\$0.50/lb	\$15-\$100 each
Residential use	Yes	Yes	Yes
Commercial use	Yes	Yes ^(b)	Not Recommended
Backwash flow time	2-5 minutes ^(c)	1-5 minutes ^(c)	Remove & wash

*Personal communications, 2010. Robert Hawkin and Scott Hyland, Neptune Benson, Coventry, RI

(a) DE and Pearlite filters should be "bumped and swirled" to regenerate the porosity of the filter medium. Actual recoat is needed only when pressure drop across filter reaches 8-10 psi, significantly reducing the number of times that new filter media is needed.

(b) DE is not recommended for apartments, condominiums, or hotels since the filters quickly become clogged with the high rate of use. Specially designed DE and Pearlite filters are made for high volume use.

(c) Typical times. Filter must be backwashed until sight glass is running clear.

Figure 7.64 in Section 7.3.7.5 shows an analysis of potential backwash water use for swimming pools in California. As this figure shows, sand filters are the least water efficient.

BMP Options – Sediment Filtration/Removal

- Only use filters where needed.
- Choose sediment filters that require the least number of backwashes.
- Examine ways to reuse backwash water or purge water.
- When filters are used, install pressure gauges and use the gauges to determine when to backwash.
- Backwash based on pressure drop instead of by a timer or a schedule.
- Cartridge filters should be the only type used in most applications since they only need to be washed off with a hose and returned to the filter housing

7.3.8.2 Physical Sediment and Precipitate Removal

The reuse of water onsite often depends on the removal of sediment and precipitates produced by a process or operation. The two most commonly found examples are coagulation – sedimentation, and filter presses and filter belts. These water treatment processes are important BMPs, themselves, and when used in conjunction with onsite water recovery and reuse.

Coagulation - sedimentation is used where large volumes of water need to be treated. This process involves the addition of a chemical that causes particles to

"clump" together (coagulate) to form heavy "flocs", which then settle out (precipitate). A full technical discussion is beyond the scope of this document, but this type of treatment is often used to treat raw surface water or even wastewater streams that can be reused within the facility. Filtration often follows coagulation - sedimentation.

Precipitate removal is often found in plating operations and other industrial/commercial operations where metal salts are used. Leaf or belt presses are often employed to remove the precipitate. Technical details are beyond the scope of this document, but these water treatment processes are important to internal water reuse operations.

7.3.8.3 Softening

Softening is the process of removing magnesium, calcium, and related multivalent ions from water. Laundries, car washes, boiler feed-water, laboratory water, hot-water systems for restaurants and food-service establishments, and metal-plating operations commonly employ softening. The three most common ways of softening water:

- Nanofiltration (See section on Membrane Processes)
- Lime softening (only applicable to large municipal systems and not discussed in this document)
- Cation exchange resins or zeolite that exchange sodium or potassium for calcium and magnesium

Cation exchange resins and zeolites are the most commonly found softening processes in CII operations. Water is passed through a bed of resin from the top. As it passes through, sodium or potassium ions on the resin are released and replaced with the calcium or magnesium cations. As water passes through the bed, spent resin (resin that has given up its sodium or potassium ions) moves down the bed. As the process continues, hard water will use up all the salt, and softening will cease; therefore, softeners need to be regenerated with a salt (typically sodium chloride - salt or potassium chloride). Sodium salts damage plants and cause clay soils to deteriorate. Softeners are often a major salt input to wastewater streams that are being recycled. For this reason, the use of softeners or the use of sodium salts has come into question. Many septic systems are also converting to the use of potassium-based salts to prevent damage to plants and soil.

BMP Options – Softeners

- Do not recharge based on timers.
- Consider demand based softener regeneration. The best systems measure the hardness and only backwash when a preset percent of the resin bed is exhausted.

- Use water meters that actuate recharge with a predetermined amount of water based on the water chemistry of the source water.

7.3.8.4 Cation and Anion Exchange

Cation and anion processes – also known as strong acid/base resins – are used when extremely pure water is required. The equipment can be recharged on or off site.

BMP Options – Ion Exchange

- Use only when needed for required water quality.
- The resin bed should be instrumented to ensure that recharge is done only when a preset percent of the bed's resin has been exhausted.

7.3.8.5 Distillation

Distillation works by boiling water to form steam condensate using either an electric or gas water still. Solid contaminants remain behind as the steam is generated, then the steam is condensed into a purified water stream. Distillers can use large volumes of water if once-through cooling water is used in the condenser, or if a reject stream is discharged from the boiler to prevent scale build-up. These systems typically waste 15 to 25 percent of water entering the system.²²⁸

BMP Options – Distillation

- Eliminate once-through cooling.
- Maximize product water recovery as a percent of total water input to 75 percent or better.
- Install automatic water and gas or electric cutoffs when the receiving reservoir is full.

7.3.8.6 Carbon Adsorption

Carbon adsorption removes organic compounds such as those that affect taste and odor. In some cases, activated carbon is also used to remove heavy metals from water. The adsorption process depends on the physical characteristics of the activated carbon, the chemical compositions of the carbon and the contaminants, the temperature and pH of the water, and the amount of time the contaminant is exposed to the activated carbon.²²⁹ Carbon adsorption can use either disposable cartridges or packed columns. Disposable cartridges are disposed of once the adsorptive capacity is exhausted. Alternatively, packed columns can be removed and recharged offsite.²³⁰

²²⁸ East Bay Municipal Utility District. 2008. *Watersmart Guidebook—A Water-Use Efficiency Plan Review Guide for New Businesses*.

²²⁹ North Dakota State University. *Treatment Systems for Household Water Supplies—Activated Carbon Filtration*.

²³⁰ East Bay Municipal Utility District. 2008.

7.3.8.7 Membrane Processes

Overview – Membrane Processes

The development of membrane technologies has revolutionized the way in which water is treated. Microfiltration and ultrafiltration remove very small particulates and colloidal substances from water. They are also capable of filtering bacteria and some viruses. Micro and ultrafiltration materials include ceramics and polymers of various types. NF and RO remove dissolved solids ranging from proteins and sugars, to minerals and salts. NF and RO typically use thin film composites, cellulose acetate, and polysulfonated and polysulfone membranes. These processes can be made of either a bundle of tubes or spiral wound filters. These assemblies are then placed into long pipe-like pressure vessels. A variant is the submersible microfiltration membrane that works on a vacuum. It is often called a membrane biological reactor (MBR) used in wastewater treatment systems.

All four of the membrane processes are important ways to recover water for onsite reuse or for the treatment of recycled municipal wastewater where very high purity is required. Table 7.52 compares the general characteristics of the four membrane technologies.

Table 7.52 - Comparison of Membrane Technologies

Type of filtration	Microfiltration	Ultrafiltration	Nanofiltration	Reverse Osmosis
Pore Size Removal (Microns)	1.0 - 0.1	0.01 - 0.001	0.001 - 0.0001	<0.0001
Operating Pressure (psi)	<30	20 - 100	50 - 300	225 - 1,000
Operating Cost (\$/1,000 gallons)	\$ 0.50 - 1.00	\$ 0.50 - 1.00	\$ 0.75 - 1.50	\$1.50 - 5.00
Source: Cartwright Consulting Company - http://www.cartwright-consulting.com				

Types of Processes – Membrane Processes

Micro- and Ultra-Filtration

Both microfiltration and ultrafiltration remove very small particulate matter from water. They find application in all areas of water treatment since these devices are able to remove *Giardia lamblia* cysts, *Cryptosporidium* oocysts, and other pathogens.

Because microfiltration and ultrafiltration are filtration processes, the membranes need to be backwashed periodically to flush precipitate from them. They also require periodic cleaning with detergent and either acid or alkaline cleaners. Both filtration processes typically have sediment filters placed ahead of them to remove larger particles before micro- or ultra-filtration, thus extending the time between backwashes and extending membrane life.

Ultrafiltration finds use in food processing operations where water must be removed from a liquid or slurry, such as the removal of whey from milk solids and water from tomato paste.

Nanofiltration and Reverse Osmosis

These technologies are capable of removing dissolved salts, proteins, and minerals at the molecular level. They find application in many industries. These two processes differ from filtration in two significant ways. Since only a portion of the water fed to the membrane is actually passed through it is called “permeate.” The remaining water is the reject or retentate stream, and it is sent to discharge as a waste stream. This reject contains the salts and minerals left behind. Like filtration membranes, these membranes must also undergo periodic cleaning with detergent and either acid or alkaline cleaners. The water produced by these processes is exceptionally low in mineral and organic contaminants.

When selecting membranes that operate at the molecular level, several terms are of particular importance:

- Permeate - the product water that passes through the membrane.
- Retentate - the water containing the dissolved salts, minerals and other substances that is sent to waste.
- Rejection rate - the percent of salts that are removed by the process.

NF and RO processes should be preceded by particulate filtration. NF removes multivalent ions and is thus a softening process, but most water fed to RO systems has already been softened to remove hardness that would quickly foul the membrane. RO technology finds application in many diverse areas, including:

- Desalination of sea water and brackish waters
- Pre-treatment for the production of ultrapure water
- Treatment of water for kidney dialysis
- Laboratory and pharmaceutical water purification
- Plating water treatment and plating solution recovery
- Product recovery for precious metals

Modern large RO units have rejection rates of 90 percent or better and permeate recovery rates of 75 percent or better. For medical and laboratory operations, the size of the system helps determine the permeate recovery rates. Smaller systems with production rates (permeate) of under three to four gallons per minute typically have only a 50 percent recovery rate. The reject water is often usable for other purposes.

BMP Options – Membrane Processes

For micro and ultrafiltration membranes:

- Use pressure drop across the membrane to determine when to backwash so that backwashing is done only when necessary.
- Follow manufacturer's recommendation on membrane cleaning to minimize the number of cleanings needed.
- Pre filter water to remove larger sediment to minimize backwash and cleaning.
- Follow the BMPs for filtration for the pre filters.

For nanofiltration and reverse osmosis:

- Choose systems with the maximum permeate recovery rates.
- Clean according to recommendations from the manufacturer.
- Investigate ways of reusing the retentate.
- Ensure good pretreatment to minimize cleaning of the membranes.

Metal-Oxide Filtration (MOF)(Ceramic)

This filtration technology uses cross-flow membrane permeation technology with Metal-Oxide Ultrafiltration Membranes to separate and remove emulsified oil and grease, heavy metals, biological oxygen demand (BOD), chemical oxygen demand (COD), total suspended solids (TSS), volatile organic compounds (VOC), color, TDS, and turbidity from industrial wastewater.

The separation process takes place inside the porous ceramic module where macromolecules and particles are continuously rejected on the surface of ceramic and water permeates across the ceramic membrane. Each ceramic module contains parallel flow channels where the feed material is introduced. As the contaminated fluid passes through these parallel flow channels the water is forced through the ceramic wall (filtrate), but pollutants (called concentrate) including fine suspended solids are rejected and returned back to the process feed tank (Figure 7.69).

The characteristics of MOF are similar to those of Ultrafiltration found in Table 7.52.

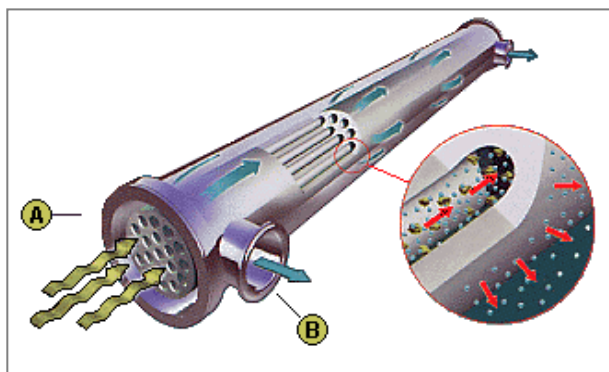

Figure 7.69 - Ceramic Membrane Diagram.

- A) filtrate, retentate or concentrate
B) permeate, diffusate or filtrate

Table 7.53 - Other Membrane Technologies

Type of filtration	Metal Oxide Filtration
Pore Size Removal (Microns)	0.8 - 0.001
Operating Pressure (psi)	50 - 100
Operating Cost (\$/1,000 gallons)	\$ 0.50 - 1.00

The flow in this type of system is open-ended on both sides of the filter and the permeate is forced through the sides of the filter wall. This means that the filters do not need to be backwashed so they can be used for many years without replacement. This type of construction minimizes membrane fouling and can operate under the following conditions: normal operating pressure from 75 – 80 psi, 0-14 pH, and 0-300 degrees F.

7.3.8.8 Other Treatment Methods

Other treatment methods can consume small amounts of water if chemicals are fed in a liquid or slurry form. Disinfection technologies include use of chlorine compounds, ozone, hydrogen peroxide, and ultraviolet light. Other commonly used chemical feed systems add antioxidants, pH control, oxygen scavengers, and other chemicals used to condition the water for its intended use.

Other processes use water to make up the solutions, but this water becomes part of the product water and is not lost. Cleaning chemical storage areas does consume water, however. The potential for water savings by choosing among disinfection technologies is small, but wasting water in cleaning equipment and storage vessels can be reduced through use of waterless methods.

Water Treatment

Water treatment is used in many commercial operations, including food services, laundries, laboratories, pharmacies, and car washes. The type of treatment depends upon the application and the required water purity. Treatment ranges from simple cartridge filtration to sophisticated systems that produce extremely pure water. For example, ice machines often have cartridge sediment and carbon filters installed on the make-up water so the ice is free of particles and chlorine taste. Some laboratories and the pharmaceutical and electronics industries, however, require “ultrapure water,” which has had all but a few parts per billion of minerals, organics, and other substances removed through a train of treatment, including filtration, carbon filtration, softening, reverse osmosis, and strong acid/base ion exchange, followed by microfiltration and ultraviolet-light disinfection. The following table compares various treatments found in commercial operations.

Many commercial operations require some form of water treatment, either for use in processes or as a component

Commercial Water Treatment Examples

	Treatment Process							
	Sediment Filtration	Carbon Filtration	Softening and Ion Exchange	Membrane Process	Distillation	Disinfection	Other	
All Food Service	x	x	x	x			x	
All Laundry & Dry Cleaning	x		x					
Hospital & Laboratory	x	x	x	x	x	x	x	
Car Wash	x		x	x				
Beverage Manufacturing	x	x	x	x		x		
Metal Plating	x	x	x	x			x	
Cooling Tower & Boiler	x		x	x		x	x	
Pool, Spa, & Water Feature	x					x		
Office & Non-process	x	x	x			x	x	

Description of End Use

Each treatment technology offers unique opportunities for water conservation, as described below:

Sediment filtration is one of the most common treatment techniques. Swimming pools, water feeds to commercial ice machines, cooling-tower side-streams, drinking-water, and water-using medical equipment are but a few examples where sediment filters are found. They remove particles down to a few microns in size. The two basic designs use disposable cartridges or granular filter media.

By their nature, cartridge filters are usually not designed for very large flows. Sample uses include pre-filters for ice machines, smaller medical equipment, and smaller swimming pools and spas. Filter material varies from tightly wound fibers to ceramics, fused powdered-metals, or other materials. Such filters are left in place until the sediment buildup causes a predetermined increased pressure drop across the filter, at which time the filter is replaced, backwashed, or removed and cleaned for reuse.



Culligan heavy-duty whole house filter

The second type of sediment filter is often found where larger volumes of water must be processed or higher levels of sediment must be removed. These include granular media such as sand, coated media (DE, cellulose, and perlite), and mixed-bed filters. All of these must be backwashed. The backwash water is generally discharged to the sanitary sewer. In some larger applications, however, the sediment can be allowed to settle out and the clarified water can be reintroduced at the head of the filtration process. Common applications include swimming pools, industrial water treatment, and side-stream filtration for cooling towers.

Carbon filtration removes chlorine, taste, odor, and a variety of organic and heavy-metal compounds from water by adsorption. Activated carbon, which has an enormous surface area per unit volume, attaches to the unwanted materials and holds them on its surfaces. Restaurants and food service providers for hospitals and other institutional operations often use activated carbon for drinking water and ice-machine feed water. It is also used in the beverage industry for taste and odor control.

Activated carbon is also used to remove pollutants in the metal-finishing industry and other operations where pretreatment to remove metals or organics is needed. These systems can employ either disposable cartridges or packed columns, where the activated carbon can be removed and sent for recharge. With both cartridge and packed-column systems, water simply passes through the carbon medium until its adsorptive capacity is used up.

Water softening employs zeolites or ion exchange resins, where calcium and magnesium ions are exchanged for sodium or potassium ions. Softening removes hardness to control scale, improves water for washing, and prevents “hard water” spots. Recharge is done with a salt solution containing sodium or potassium cations, the most common being sodium chloride (table salt). Water is used in the recharging process to make up the brine solutions and to purge the softener of brine prior to being returned to service. All softener systems should be equipped with controllers that are activated based upon the volume treated, not on timers. They should either be adjusted for the hardness of the water supply or be equipped with a hardness controller that actually measures the hardness and volume treated, if the hardness of the feed water varies.

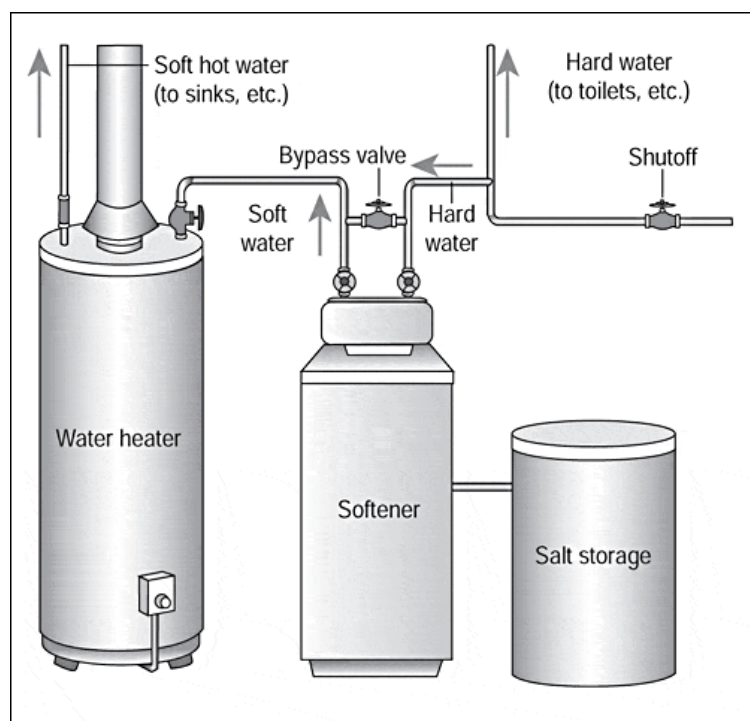

Water Softener System

www.bobvila.com/howto_library

- Microfiltration employs membranes that remove particles of 0.1 to 10 microns in size or larger. It is used in municipal water treatment to remove bacterial and *Giardia lamblia* cysts, and *Cryptosporidium* oocysts. Water is forced through the membrane until the pressure drop reaches a set point. The filter is then backwashed. The membranes also require periodic chemical cleaning. Both the backwash and cleaning processes use water. Retentate or waste volumes are usually a small percentage of the total feed volume. The retentate is often recirculated and only a small stream of “bleed water” is discharged as wastewater. Some ceramic filters can also filter in this range.
- Ultrafiltration operates at higher pressures than microfiltration and removes materials that are much smaller, including viruses and proteins. It is often used to separate milk and whey. These filters must be backwashed and cleaned in a manner similar to microfiltration membranes.
- Nanofiltration membranes have pore sizes midway between those of ultrafiltration and reverse osmosis. Nanofilters are often referred to as “softening” filters, since they are effective in removing multivalent cations such as calcium and magnesium.
- Reverse osmosis (RO) removes salts from a water stream. It finds use wherever very pure water is needed, such as laboratories, medical uses including kidney dialysis, metal plating, boiler feed-water, and a number of related applications. Typically, RO will reject 90 to 95 percent of the salts. RO is also used before strong acid/base deionization for the production of ultrapure water for laboratory, pharmaceutical, and microelectronics manufacturing operations.

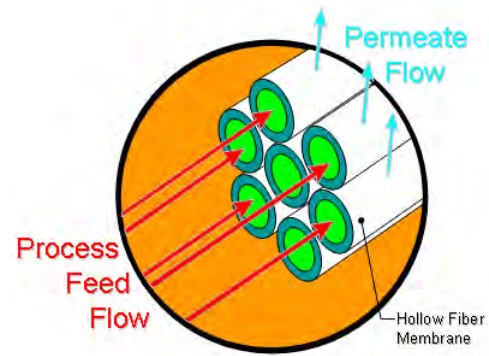

Permeate/Feed-Stream/ Retentate Diagram

Koch Membrane Systems
www.kochmembrane.com

Distillation, a process once in common use to make water for laboratory applications, is still found in many laboratories. Electric or gas stills are used. Production quantity depends upon the size of the still. Smaller stills often use once-through condenser water and can waste huge volumes of water to produce a single gallon of distillate. Small and medium size stills use air to cool the coils and have no discharge. These are the most water-efficient stills. Some larger stills have reject streams to prevent scale buildup. These typically dump 15 to 25 percent of the water entering the still.

Disinfection and other technologies can consume small amounts of water, if chemicals are fed in a liquid or slurry form. Chemical disinfection technologies include use of chlorine compounds, ozone, and hydrogen peroxide, as well as pH control with acids and bases and the addition of antiscalants and sequestrates such as sodium hexameta phosphate. Ultraviolet light, heat, and extreme mechanical shear are among other technologies in use.

It is important to examine disinfection requirements. Ultraviolet light, heat, and mechanical shear processes do not use water. Other processes use water to make up the solutions, but this becomes part of the product water and is not lost. However, cleaning chemical storage areas does consume water. The potential for water savings by choosing among disinfection technologies is not great; however, the potential to waste water in cleaning the equipment and storage vessels is a concern which use of waterless methods can lessen.

Water-Savings Potential

The first water-saving possibility for water treatment is to question the need for additional treatment. If treatment is cost-effective, choose methods that need the least amount of cleaning and backwash or that

have reject streams. All membrane processes produce a reject stream, which in the case of nanofiltration and reverse osmosis might be reusable.

Cost-Effectiveness Analysis

Cost analysis depends upon many variables. Equipment costs for water treatment processes vary from tens to hundreds of thousands of dollars. For select industries, some level of purified water is essential to operation and is an unavoidable cost. Since many variables are involved in analyzing water-treatment alternatives, a cost-benefit analysis, including the cost of energy, should be conducted for each application to determine the most feasible water-treatment option.

Recommendations

Proven Practices for Superior Performance

- For all filtration processes, require pressure gauges to determine when to backwash or change cartridges.
- For all filtration processes, base backwash upon pressure differential.
- For all ion-exchange and softening processes, require recharge cycles to be set by volume of water treated or based upon conductivity controllers.
- Require that all softeners be recharged based upon the amount of water they process (demand-based) or by actual measurement of the grains of hardness removed.

Additional Practices That Achieve Significant Savings

- Use water treatment only when necessary.
- Choose a reverse-osmosis or nanofiltration system with the lowest reject rate for its size.
- Choose distillation equipment that recovers at least 85 percent of the feed water.
- Evaluate opportunities to reuse backwash waste streams.

References

APS Water Services Corporation. www.apswater.com/.

Barnstead International (2555 Kerper Boulevard, Dubuque, Iowa USA 52001-1478.). **Classic Electrically Heated Stills — Operations Manual.**

Doulton USA (19541 Cherry Hill Rd., Southfield, MI 48076). www.doultonusa.com/.

Gibbs, Eric L., Ph.D. July 2001. **Preparation of Reagent Water — Design of Laboratory Water Stills.** High = Q, Inc. www.high-q.com/articles.html.

Hoffman, H. W. (Bill), and Sutton, John T. 2003. **State Energy Conservation Office Suggested Water Efficiency Guidelines for Buildings and Equipment at State Facilities.** Texas State Energy Conservation Office. Austin, Texas.

Hoffman, H. W. (Bill). March 2006. **Building Reduced Water and Wastewater Cost into the Design.** Austin Water Utility. Austin, Texas.

Klenck, Thomas. **How Softeners Work.** Ahdorma Water Filters Purification and Treatment (320 Rolling St., #401, Brooklyn, New York). www.thewatersite.com/how_they_work_water_softeners.htm.

Koch Membrane Systems. www.kochmembrane.com.

Loretitsch, Gary. **Guidelines for Managing Water in Cooling Systems: For Owners, Operators, and Environmental Engineers.** Puckorius & Associates. San Jose/Santa Clara Water Pollution Control Plant.

Makini, Byron. Fall 2005. **Achieving Zero Liquid Discharge in the Semiconductor Industry.** Columbia University, Department of Earth and Environmental Engineering. New York, New York.

McDermitt, Kery. August 10, 2006. **RO System Helps Unilever Reduce Water Usage.**
WaterandWastewater.com.

McIntyre, James P. August 1998. **Industrial Water Reuse and Wastewater Minimization.** BetzDearborne.

Neptune Benson, **Defender Automatic Regenerative Filter** (6 Jefferson Drive, Coventry, Rhode Island 02816). Neptunebenson.com.

North Carolina Department of Environment and Natural Resources, Division of Pollution Prevention. August 1998. **Water Efficiency Manual for Commercial, Industrial, and Institutional Facilities.**

Pacific Northwest Pollution Prevention Research Center. **Pollution Prevention Technology Profile: Conductivity Controls in Water Rinsing, Cooling.**

Thompson, Chris; and Lickteig, Edward. October 2008. **Recycling High Purity Rinsewater at Samsung Austin Semiconductor.** Ultrapure Water, Samsung Austin Semiconductor. Austin, Texas.

Towers and Boilers. February 2005. Seattle, Washington.

Wilcox, Daniel. 2005. **AMD Austin Water Conservation Summary.** Advanced Microdevices (AMD). Austin, Texas.

Table 75 Summary of key water efficiency recommendations for food and drink manufacturing

Water efficiency option	Why and what it involves
1 - Optimise pressure	Water supply pressure found to be too high leading to unnecessary use through hoses, taps etc.
2 - Balance/ supply leak	Impossible to balance 'water in' against 'water out' across a site leading to suspect that there may be leakage on the distribution system.
3 - Repair process leaks	Leaks within the process equipment e.g. flanges or valve seals could be repaired. Usually a preventative maintenance issue.
4 – Restrict flow through taps	Food and drink factories have a high number of taps in hygiene (hand washing) stations. These are used by operatives to wash hands on entering/leaving the production environment. Often flow through these taps is unnecessarily high.
5 - Automatic shut-off	Many points of water use do not need to flow when there is no product or the production line has ceased operation. Often there is no automatic shut-off to turn off water when not required.
6 – Re-use of cooling water	Some items of plant commonly used in food production use water for cooling, e.g. vacuum pumps, sealers or homogenisers. It is surprising how many times once-through as opposed to closed circuit cooling is still in use.
7 - Pump gland/seal water	Many pumps have a packed gland requiring lubrication to maintain the seal. The water supply to this need only be running when the pump is operating – often it flows continuously. Also packed glands can often be replaced by mechanical seals which require no or very little water.
8 – Recover and re-use condensate	Wherever steam is used to heat a vessel or pipe, condensation is formed. This is hot and of sufficient quality to be and returned to the hot well for re-use in the boiler. Often it can be found flowing to drain.
9 - Control overflows	Many vessels or flumes have a set capacity but due to water losses need to be topped up to maintain the correct level of water – but if poorly controlled this often leads to unnecessary overflows.
10 - Optimise washing	Often excess water is used for washing operations – reduced flow, better spray design or alternative washing methods may often be employed.
11 - Recover process water	Sometimes water used in one process may be collected and used (with or without treatment) directly in another making immediate water savings.
12 - Recover RO reject water	Reverse osmosis (RO) treatment leads to a reject water - in many installations where this is treating softened water the reject water (approx. 30% flow) is no more than 'concentrated' soft water and can often be re-used directly with no further treatment.
13 - Cooling tower loss	Cooling towers may lose or use more water than needed owing to poor blowdown (purge) control or poor water treatment.
14 – Treatment of effluent for the recovery of water for reuse	Treatment of effluent for the recovery of water for reuse is often not undertaken because of perceived water quality risk. It is important to note that, typically, the treatment of effluent for the recovery of water for reuse requires significant and robust water treatment.
15 – Washrooms	Employee water use (washrooms) on most manufacturing sites is a very small proportion of the total use and while often offering immediate and cost-effective water efficiency improvements these are typically very small when compared to other opportunities.

From a detailed analysis of the recommendations made across each of 27 of the FHC on-site water reviews (with an identified potential savings of 0.6 million m³ water per year), it is possible to group the water efficiency recommendations identified into 15 key areas, as shown in Figure 41.

Water Quality and Water Conservation

Water is used in the following processes: cleaning equipment, washing fruits and vegetables, conveyance, cooling, peeling, blanching, pasteurization and boiler feed. For information on how to properly dispose of wastewater, call Ecology's regional Water Quality Program for assistance.

◆ Wastewater

The following discussion focuses on wastewater generated from process and cleaning waters.

Reduction and Recycling Opportunities

- ▲ Set water conservation goals.
- ▲ Make water conservation a management priority.
- ▲ Install water meters and monitor water use.
- ▲ Train employees how to use water efficiently.
- ▲ Use automatic shut-off nozzles on all water hoses.
- ▲ Use high-pressure, low-volume spray washes during clean-up to conserve water.
- ▲ Use automatic valves on spraybars to shut off water flow when equipment is not running.
- ▲ Eliminate once-through cooling water usage by recycling or reusing whenever possible.
- ▲ Minimize spilling ingredients and product on floors; always clean up the spills before washing.
- ▲ Don't let water run continuously unless necessary.
- ▲ Use dry (waterless) cleaning methods prior to water clean-up. Don't let people use water as a broom.
- ▲ Survey systems for leaks and repair. Heat exchangers and other "non-contact" water systems, in particular, need to be inspected routinely. Conductivity or pH monitors on cooling lines can positively detect leaks.
- ▲ Use automatic controls to keep cooling waters in correct temperature range.

- ▲ Install lock out valves for proper process water flow levels.
- ▲ Segregate wastewater streams according to level and type of contamination, and investigate the potential for recovery.
- ▲ Keep storm waters out of wastewater. Manage storm waters separately.
- ▲ Recover starch from wastewaters. It is possible to reduce half of the suspended materials in the water and reduce the consumption of clean water.
- ▲ Use mechanical peeling to reduce water usage, chemical pollution and energy consumption.
- ▲ Use dedicated process or mixing lines for certain products to reduce change over clean-ups.
- ▲ Reuse process waters to clean equipment when technically and regulatorily feasible.
- ▲ Filter process and cleaning water to remove particulates; reuse the water.
 - screening
 - hydro sieves
 - membrane filtration: micro-filtration, ultrafiltration, reverse osmosis.
- ▲ Use compressed air to clean equipment or parts when appropriate.
- ▲ Install multiple rinse tanks in a counter-current series system to reduce wastewater.
- ▲ Clean with steam to reduce the volume of water used for cleaning.
- ▲ Reuse process water to the maximum extent possible.
- ▲ Reuse compressor cooling water.
- ▲ Reuse water-cooled condenser water as process or clean-up water.
- ▲ Use a cooling tower or reuse cooling water to conserve water.
- ▲ Use water extracted from juice as boiler make-up, when possible.
- ▲ Use a dry extraction process, if applicable.
- ▲ Use warm process water as defrost water.
- ▲ Use process waters to wash trucks.

The semiconductor industry's typical plant produces ultra-pure water at great expense. Larger plants will be more aware of the large absolute total cost of processed water and will be conscious of the opportunity for cost-effective investment to reduce those costs. Smaller plants, because of the relatively larger impact of fixed costs, will regard water costs as less significant than other costs. But the total quantities of water used in the semiconductor industry are much smaller than those used in large chemical process, refinery or pulp and paper plants.

Semiconductor manufacturers expect their total water consumption to be linear with production. They expect a doubling of production to require a 30 percent increase in water usage and a 50 percent variation in production to require a 15 percent change in water use. This indicates a significant base load water usage.

WATER CONSERVATION FOR SIC GROUPS STUDIED

Conservation Measures Adopted by Responding Firms

Pequod asked that responding firms address a number of general and specific questions concerning conservation, including individual measures, savings achieved, cost of individual measures, economic criteria, overall savings from conservation programs, trends in water usage and anticipated water-related projects at the individual sites.

We asked whether any one of a series of specific examples of conservation measures was practiced. This gave respondents the opportunity to answer easily by checking the item. The conservation measures adopted by all the responding firms are summarized in the following table.

Table 3 Conservation Measures and Investments, by SIC Reported on Survey Questionnaires				
Conservation Measure	SIC	Number of Measures Reported	Water Conserved in Million Gallons per Year	Total \$ Investment for Each SIC Group
Recycling Cooling or Process Water	201	3	7.0	14,000
	208	1	8.5	16,000
	261/262	1	365	NR
	281	2	33,000	40,000
	282	1	500	NR
	291	4	167	156,000
	3674	4	56	14,000

Sequential Reuse	201	1	0.5	5,000
	208	1	41	77,000
	261/262	1	730	NR
	282	1	40.5	10,000
	286	1	26	20,000
	291	4	320	403,000
	3674	3	55	26,000
Improved Control Systems	201	2	6.2	35,000
	208	1	20	38,000
	281	1	200	1,000,000
	282	2	302	25,000
	291	3	234	149,000
Dry Cooling	201	1	1.3	NR
	208	1	3	6,000
	261/262	1	7.3	NR
	282	1	25.6	20,000
	291	1	NR	3,000,000
Changed Cleanup Procedures	201	3	12.5+	NR
	281	1	0.26	NR
	282	1	36.5	NR
	291	3	7.1	1,752,000
Changed To/From Continuous Processing	3674	1	2.8	NR
Changed/Reduced Flow Rate	201	6	46+	6,500
	208	1	3.2	6,000
	281	1	0.13	500
	286	1	8.8	15,000
Automatic Shutoffs	201	2	16.9	7,000
	281	1	3.7	5,000
	286	1	5.3	2,000
Smaller Tanks, Sinks		NR		
Lower Flow Settings	201	2	0.03	5,000
	261/262	1	18.3	25,000
	291	1	0.1	5,000
Leak Monitoring and Repair	201	2	0.26	26,000
	281	1	0.03	500
	282	1	11.37	3,000
	286	1	105	NR
Changed Irrigation Practices	281	1	0.03	NR
	3674	1	0.3	8,000
Production Shutdown/Relocation	282	1	730	110,000

NR = None Reported

A review of Table 3 and of the underlying detail presented in the database leads to the following observations.

1. The returned questionnaires reported remarkably few water conservation measures undertaken, or we did not present sufficient choices.
2. Some switches have been made to alternative water supplies to obtain a better or cheaper source or one with fewer restrictions, but these were not conservation measures even if sometimes there were incidental savings in consumption.
3. Conservation measures often achieved quite small savings relative to total water consumption.
4. Many conservation measures cost very little, ranging from zero to \$10,000 and rarely over \$50,000. Measures of a given type vary greatly in cost and in terms of savings achieved.
5. Many measures are likely to have been undertaken for non-economic reasons.
6. Not all measures reported were assigned a cost and some of the largest claimed savings were not associated with a cost.

After many follow-up conversations with responding firms it became clear that in many, if not all, cases, the responding persons had no complete file of all water-related activities undertaken at their sites within the past ten to fifteen years. Personnel assignments have changed, and those now reporting have often not been in their present positions very long. Many acknowledged that their knowledge of conservation measures was incomplete, and that the overall savings claimed were estimates based on only most recent measures. Consequently, Pequod concludes that underreporting is significant, both as to individual measures and as to the cumulative effects of conservation measures previously undertaken. This is significant with regard to future conservation programs, especially by those not heretofore committed to conservation.

Recycling as a Conservation Measure

Recycling is not widely practiced in the sense of reusing water for another purpose, either by rerouting or by first treating and then reusing. Cooling towers are the principal "recycling" operation reported, and in cooling towers, this recycling is simply a part of the cooling process in use at the plant.

Alternate On-Site Water Sources

Many large commercial and industrial facilities can use water that is less than-potable quality for processes. There are a number of opportunities for various sizes and types of businesses to develop alternate on-site water sources. Some processes, however, require very high quality source water, so some types of reuse water require additional treatment to remove contaminants or constituents. Even typical disinfection by-products found in potable water must often be removed by specialized filtration, so such sophisticated processes can as readily begin with non-potable source water.

Alternative sources of water, which can be found on-site and used in these processes, may include:

- rainwater and stormwater
- air-conditioner condensate
- filter and membrane reject water
- foundation drain water
- cooling-tower blowdown
- on-site treated gray water and wastewater

Potential uses of alternate on-site sources of water include:

- irrigation
- cooling-tower makeup
- toilet and urinal flushing
- makeup for ornamental ponds, pools, or fountains
- swimming pools
- laundries
- processes
- any other use not requiring potable water

The use of treated effluent or reuse water provided by a publicly-owned water-treatment facility is not addressed in this section.

The initial step in determining the potential for alternate water sources is to identify the requirements — including water quality — that non-potable water can satisfy. After verifying that some demands can be met by non-potable water, determine the volume and quality requirements for the potential use. Each section below provides criteria for evaluating a potential water supply and includes basic considerations for system design, although, due to the site-specific nature of both non-potable water demand and potential supply, these are necessarily broad. The final section discusses the potential and design considerations for conjunctive use.

Source design and evaluation considerations include:

Potable water from a municipal water supply is often not necessary for commercial and industrial facilities. Either they require water of lesser quality or their processes require water that must be of much higher quality.

- determining volume and quality of the available on-site source
- identifying possible uses
- matching water quality to type of use
- deciding the type of treatment, if needed
- considering other basic factors for system design

Due to the unique circumstances of site size and orientation, air-conditioning loads, impervious cover, and water-quality constraints of the proposed end use *versus* the source water, cost-effectiveness evaluations are unique to each proposed business or industrial process. As a result, a number of techniques require a feasibility study at the proposed site to determine cost implications and payback period.

Rainwater Harvesting

Rainwater falls on large and small facilities alike. However, facilities with large areas of impervious cover can capture runoff and use the water for various non-potable purposes with little treatment. This section deals with methods available to facilities that capture water from their roofs. Those that capture water from paved surfaces are dealt with in the “Stormwater” section. Harvested rainwater can also be combined with air-conditioner condensate, the next option.

The type of roof surface impacts the quality of the rainwater runoff. For the highest quality rain water, especially if the water is to be used for drinking purposes or in-building uses such as flushing toilets and urinals, harvesting should employ smooth metal roofs and non-toxic, non-leaching surface finishes. Gutter design should employ at least a 1 percent slope and route water to a central collection point for transfer to a cistern or storage tank. The system will need a “roofwasher” or “first-flush diverter” to minimize the debris and detritus from the roof surface that enters the cistern.

For rainwater destined for landscape watering, consideration should be given to diverting water directly into landscaped areas, with swales and berms to capture and direct the flow. Care must be taken in designing such landscape rainwater harvesting to avoid long-term pooling of water and creation of potential insect vectors. Costs are considerably lower for systems which do not include tanks or cisterns, and slowing the water down to allow it to percolate into the landscape has stormwater runoff reduction benefits as well.

Approximately 0.62 gallons of water can be collected per square foot of collection surface per inch of rainfall. In practice, however, most installers assume an efficiency of 80 percent. Some rainwater is lost to first flush, evaporation from the roof surface, or splash-out from the gutters. Rough collection surfaces are less efficient at conveying water, and water captured in pore spaces is lost to evaporation.

The inability of the system to capture all water during heavy storms also affects practicable efficiency. For instance, spillage may occur if the flow-through capacity of a filter-type roofwasher is exceeded, and overflow rainwater will be lost after storage tanks are full.

The use of rainwater collection systems, also referred to as cisterns, is most practical in regions with periodic precipitation throughout a plant’s growing season. For example, in California, since most regions don’t receive precipitation during the summer, early fall, and late spring, cisterns are far less practical than in other parts of the country, because very large storage capacities are needed to capture enough water to use at any length into the irrigation season. Stated another way, the more frequent the precipitation, the smaller the needed storage facility and the less the capital costs.

Calculations

Annual production potential:

$$\text{gallons} = \text{roof area (sq. ft.)} \times \text{annual precipitation (in.)} \times (0.62 \times 0.8)$$

Required annual storage capacity for the planned landscape should be determined as follows:

- Calculate the monthly water budget for the planned landscape using the water budget calculations in the section, “Landscape Irrigation Efficiency.”
- Estimate the monthly average rainfall quantities that could be harvested, based upon roof area and rainfall for the location.
- Estimate the amount of rainwater storage that would be cost-effective to construct, based upon monthly inflows from rainfall and outflows based upon the landscape water budget.

Recommendations

Proven Practices for Superior Performance

- Plumb gutter systems to facilitate rainwater catchment at commercial facilities.

Additional Practices That Achieve Significant Savings

- Have new commercial developments with more than 20,000 square feet of roof area to provide a preliminary feasibility study, including cost analysis, to determine whether rainwater harvesting is viable at the site.

Stormwater

Stormwater capture and reuse offers many unique opportunities and should be examined when stormwater systems are being designed. All new properties are now required to integrate stormwater management for water-quality purposes into the design (USEPA). The section, “Landscape Irrigation Efficiency,” discusses this topic in detail. Stormwater can be a valuable source for landscape irrigation, but only if it can be captured and held. The overall concept is to keep the rain on the site where it falls to the maximum extent possible. The water captured and held can displace part or all of the potable water otherwise used for irrigation and can optimize groundwater infiltration, water quality, and slow-release augmentation of local streams.

There are three ways this can occur:

- storage in the soil profile
- capture in on-site features, such as berms, swales, rain gardens, or terraces
- capture in a detention structure, such as a pond, from which it can be pumped back to the landscape

The first two rainwater-harvesting methods offer capture and reuse in relationship with stormwater control systems. Therefore, these often least-costly methods of harvesting rainwater also maximize the potential for stormwater to infiltrate groundwater resources. The section on “Landscape Irrigation Efficiency” includes design considerations. The newer Best Management Practices (BMPs) for stormwater control also enhance the ability to use stormwater as a resource for the landscape, even in more arid climates.

Recommendations

Proven Practices for Superior Performance

- Include capture in on-site features, such as berms, swales, rain gardens, or terraces, and the use of soil as a water-storage medium jointly in the design of landscape and stormwater facilities.

- Require stormwater ponds to be established or enlarged to accommodate long-term storage for landscape irrigation and other uses.

Additional Practices That Achieve Significant Savings

- Examine the potential of captured and stored stormwater along with other on-site water sources.

Air-conditioner Condensate

Require plumbing of heating, ventilation, and air-conditioning (HVAC) systems such that commercial and other types of facilities can collect air-conditioner condensate. Clarify in local ordinances the specific plumbing uses of alternative sources of water and their relationships to the potable-water system. This can be combined with previously described options for rainwater harvesting.

Condensate-recovery water can be used as make-up water for cooling towers. Due to its high water quality, it increases the cycles of concentration achievable in cooling towers. Condensate can also be used for irrigation and other non-potable uses. In the past, regulations have required that condensate be plumbed to the sanitary sewer. If it is used for landscape irrigation, provisions may have to be made to divert water collected during coil cleaning to the sewer, if copper concentrations would be of concern.

Since air-conditioning condensate production depends upon cooling load, relative humidity, and make-up-air volumes, someone familiar with psychometric relationships and air-conditioner system design must carefully calculate the amount of condensate produced.

Examples combining harvested rainwater and air-conditioner condensate include:

- The University of Texas, where combined sources provide an estimated average of 110,000 gallons of water a day, of which air-conditioner condensate makes up as much as half
- The Austin Resource Center for the Homeless (ARCH), where toilet flushing and landscape irrigation use rainwater and air-conditioner condensate.

Recommendations

Proven Practices for Superior Performance

- Change regulations that require condensate to be discharged into a sewer to allow for other alternative uses.
- Commercial sites with more than 100-tons of air-conditioning must examine the feasibility of diverting all condensate drain water to a common point where it could easily be captured.

Filter and Membrane Reject-Water Recovery

Require plumbing of large and very-large filter and membrane systems to recover water that can then be used for landscape irrigation and other purposes. The product stream of membrane filters is water destined for the filtered end use and a reject stream traditionally routed to the sanitary-sewer system. However, other than elevated TDS, this water is often usable for other on-site purposes. When used in landscape irrigation, proper selection of landscape materials with high salinity tolerance is necessary. In specific circumstances, filter reject water may be used in other processes within a plant. Refer to sections on “Pools, Spas, and Fountains” and “Landscape Irrigation Efficiency” for additional information.

Examples of the use of filter-backwash and membrane reject water include:

- Swimming-pool backwash water at several City pools in Austin, Texas, is used to irrigate parkland.

- RO reject water, combined with water from a stormwater pond, is used for landscape irrigation at a major microelectronics manufacturing plant in Austin, Texas.
- Many industries use RO-reject water for cooling-tower make-up.

Recommendations

Proven Practices for Superior Performance

- New projects that employ filtration and membrane processes must provide a feasibility summary study of how these sources might be employed.

Foundation Drain Water

Foundation drain water, another source on large commercial campuses, is captured to preserve foundation integrity. It is typically routed through French drains to a common sump, where it can be gathered and pumped to replace potable water for uses such as landscape irrigation.

The purpose of a foundation drain is to remove water that could potentially harm the foundation and funnel it, by gravity flow, away from the building to a low spot in the landscape. A traditional foundation-drain system does not concern itself with the water after it leaves the drain outlet. Depending upon the location, this can involve very large quantities of water. Proper use of filter cloth or drain tile is necessary to prevent clogging of the drain lines. If designed in connection with a subsurface pipe system similar to a leach field, foundation drain water can be distributed over a larger area. Combined with appropriate landscaping, this can reduce or eliminate the need to use potable water for irrigation.

Recommendations

Proven Practices for Superior Performance

- New projects that employ filtration and membrane processes should provide a feasibility summary study of how these sources might be used.

Cooling-tower Blowdown

Evaluate the feasibility of reusing cooling-tower blowdown water for another purpose, such as diversion for compressors, vacuum pumps, and other equipment with water-cooled air-condenser units. A detailed analysis is beyond the scope of this section, but any such project should be closely coordinated with local stormwater and water-quality officials, since the type of cooling-tower water treatment will determine the quality of the blowdown water. Using blowdown water may offer a classic example of tradeoffs. In the section, “Thermodynamic Processes,” achieving the maximum numbers of cycles of concentration was a goal. This was based on a stand-alone cooling-tower operation. In this case though, if the need for irrigation water exceeds blowdown volumes at the site, the designer may wish to consider reducing the cycles of concentration and, instead, choose treatment that will produce blowdown suited for irrigation purposes. This also avoids water-quality problems for streams receiving runoff from the property. The net benefits of using blowdown are that it makes use of all the water entering the tower, displaces potable water use for irrigation, and eliminates wastewater discharge from the tower.

Another option is to use nanofiltration or RO to treat tower make-up water so that extremely high cycles of concentration can be achieved. Reject water can then be used for irrigation.

Recommendations

Proven Practices for Superior Performance

- New projects that employ filtration and membrane processes should provide a feasibility summary study of how these sources might be used.

On-site Treatment of Gray Water and Wastewater

Gray water is defined in California law as “untreated waste water which has not come into contact with toilet waste. Gray water includes waste water from bathtubs, showers, bathroom wash basins, clothes-washing machines, and laundry tubs, or an equivalent discharge as approved by the Administrative Authority. It also does not include waste water from kitchen sinks, photo-lab sinks, dishwashers, or laundry water from soiled diapers,” in Title 24 section 5 of the Code. The use of gray water or on-site treatment of wastewater for on-site reuse requires a project-by-project analysis and is beyond the scope of this document. However, many commercial projects have employed technologies ranging from simply using septic tanks and near-surface dosing of the effluent for subsurface irrigation to the installation of full-capacity wastewater-treatment plants, followed by conventional landscape irrigation. Another example is treating effluent to a quality sufficient for toilet and urinal flushing.

As an example, the 250-unit Solaire Apartments in Battery Park was a private-public partnership and is the first “green” residential high-rise building that incorporates advanced materials, energy conservation, and water reuse in an urban setting. The Solaire Apartments selected the ZENON Membrane Solutions proprietary ZeeWeed MBR (membrane bioreactor) process to treat, store, and reuse wastewater for toilet flushing, irrigation, and cooling towers. This approach reduces the fresh water taken from the city’s water supply by more than 75 percent and significantly decreases energy costs, since less drinking water is pumped from the city’s treatment plant and wastewater is not transferred to the city’s wastewater treatment system. The system is the first on-site water-recycling system in the U.S. built inside a multi-family, residential building.

Gray water from wash basins, bathing and showers, and laundry operations has also been considered.

A primary concern is to involve health-department, code-enforcement, and stormwater-quality officials in the design and development of any project to ensure that all applicable environmental concerns are taken into account, that appropriate technologies are employed, and that regulations are met.

Recommendations

Proven Practices for Superior Performance

- New projects that employ filtration and membrane processes should provide a feasibility summary study of how these sources might be used.

Multiple Sources

Plumbing of rainwater, gray water, drain water, and blowdown from various sources to common end uses, like landscape irrigation, or non-potable indoor uses, such as toilet flushing, is not common, but is recommended. Cost effectiveness of such “hybrid” systems is improved by diversifying the sources of water and improving the consistency of water availability, since rainfall episodes, often the largest and most significant single source of water, are sometimes separated by long dry periods.

Gray water generally does not contain fecal matter and, thus, can more easily be treated and reused on-site. Gray water requires simple filtration to remove suspended particles and, when stored, requires only treatments such as chlorination for odor or aeration for nutrients in the water.

Recommendations

Proven Practices for Superior Performance

- Clarify in local ordinances the specific plumbing uses of alternative sources of water and their relationships to the potable-water system.

3.9.3 Stormwater collection

For food processing plants with large roof areas, collecting stormwater may be an option to supplement existing supplies. Rainwater collected from roof surfaces can be of suitable quality for non-process applications such as cooling water. It is estimated that a factory in the Brisbane region with a roof area of 6500 m² could potentially collect 6500 kL/year with an average rainfall of 1000 mm/year (ABM 2003) saving around \$6500. For a capital outlay of \$15 000, including storage tank and treatment unit, the payback period could be around two years.

Case study

Stormwater collection: ginger processor, Australia

Buderim Ginger in Queensland harvests stormwater from the ground floor of its green ginger receiving area and the roof of the ginger wash plant. A first flush system directs the initial volume of rainwater to the wastewater treatment plant and the remainder is directed to the wash collection pits. The water is used for the initial wash of fresh ginger from the farm.¹

¹ UNEP Working Group for Cleaner Production 2003k



Eco-efficiency action

- Identify relatively clean wastewater streams and attempt to match them with your plant's water demands (e.g. recycle through process equipment or reuse for other plant operations).
- Investigated changing single-pass systems to closed-loop systems. Alternatively, find another use for discharged single-pass cooling water.
- Identify whether treated wastewater streams could help to meet the plant's water needs.
- Investigate the recovery of filter backwash water.
- Consider opportunities to use treated water in the cultivation of crops, or for forestry operations or land rehabilitation.
- Investigate the use of treated wastewater as a nutrient food supply for algae and fast-growing species of duckweed for stockfeed.
- Consider the viability of collecting stormwater to supplement water supplies.

3.1.2. Industrial

Industrial uses of reclaimed water include both cooling water and process water, such as pulp and paper manufacturing, chemical manufacturing, textile production, and petroleum and coal development/production. Texas regulations currently authorize the use of reclaimed water for cooling tower makeup water. Specific water quality requirements will vary by industrial application, with some processes necessitating the application of additional treatment technologies to match exact water quality needs. For example, some industrial processes within the electronics industry will require water of nearly distilled purity that can be supplied with reclaimed water treated using membrane filtration, while a paper manufacturer may establish specific color requirements. Because industries tend to use reclaimed water at a constant rate through the year, they provide good opportunities for year-round use of reclaimed water.

While water quality requirements and treatment will be industry specific, use of reclaimed water for cooling is a significant use where total dissolved solids, hardness, ammonia, silica, and dissolved oxygen are specific concerns due to scaling or corrosion in pipes or heat exchangers. Residual organic matter and nutrients may contribute to biological growth in heat exchangers and cooling towers. Microorganisms can also induce corrosion or fouling and can present a potential health risk to employees.

3.1.3. Agricultural

Similar to urban reuse, direct agricultural reuse opportunities are also dictated by water quality requirements. Texas regulations allow for reclaimed water to be used for:

- Irrigation of food crops;
- Irrigation of pastures;
- Irrigation of sod farms;
- Irrigation of feed crops; and
- Silviculture.

The major human health concern associated with using reclaimed water for agricultural irrigation is the potential for food crop contamination by microbial pathogens, particularly for foods eaten raw. Pathogens can survive on plants and in soil for extended periods of time. Thus, if reclaimed water is used for food crops not treated to destroy pathogens, the crops should be commercially processed in a manner that will destroy pathogens prior to being distributed for human consumption. Water salinity, particularly chloride and sodium concentration, is another important factor in determining whether reclaimed water can be used for agricultural irrigation. As salinity increases in irrigation water, the probability for certain soil, water, and cropping problems increases (Ayres and Westcott, 1976) unless irrigation water is properly applied and managed (also see Section 6.1.4). Plants tend to vary widely with respect to their tolerance to salinity, and provision of adequate soil drainage and irrigation management practices will help alleviate potential problems associated with the salinity of irrigation water. As with urban irrigation uses, the use of reclaimed water for agricultural irrigation has recently received

CASE STUDY:

CADBURY
water reduction commitment

Cadbury's Ringwood site in Victoria is working to reduce water use by 40 per cent through innovative water management projects that are part of Cadbury's global Purple Goes Green Initiative.

The major uses of water at the site are associated with cooling towers, production processes, domestic appliances and boilers. Cadbury has recently secured grant funding through the Victorian Smart Water Fund, which will contribute towards a \$1.2 million project to reduce total water consumption by 40 per cent by 2009-10.

Using 2006 as a base year for water use, in 2009 Cadbury Ringwood is on track to meet its target of using 40 per cent less water than it did in 2006.

This reduction will be achieved through:

- Installing a water recycling system aimed at reducing the volume of water consumed by vacuum pumps, saving 5,500 kilolitres of water each year (more than two Olympic swimming pools)
- Changing from water absorption chillers to electric drive chillers, which reduces cooling tower water use and installing equipment and systems to reduce evaporative water loss
- Fitting flow control valves to hand washing basins and retrofitting bathrooms with waterless urinals



- Installing rainwater tanks (up to 1 million litres in size) for supply of water to the cooling towers and toilets (total Cadbury Ringwood site storage of 2 million litres)
- Programs aimed at engaging staff in creating a water wise culture within the organisation such as showerhead exchange programs.

CASE STUDY:

SARA LEE AUSTRALIA
trade waste water improvement project

In Australia, the Sara Lee Bakery Division operates a large manufacturing facility at Lisarow, on the Central Coast of NSW, which produces a wide range of consumable goods for the local and export market.

This site chemically treated trade waste prior to discharge to the sewer for a number of years. The existing plant consisted of a 90,000L balance tank followed by a clarifier for solids separation and removal via flocculation and air floatation. The wastewater was then discharged to the sewer, with the plant having minimal automatic process control.

Sara Lee Australia identified a significant opportunity to improve the treatment process, both reducing trade waste charges and improving the environmental

performance of the plant. Working with Integra treatment solutions, Sara Lee decided to add a biological phase to the wastewater treatment process. A 250,000L biological reactor tank was introduced, and the general plant configuration and flow dynamics were also changed and refined in a staged process improvement over the course of the project.

Key aspects of the project were:

- Commissioning of the biological reactor and installation of jet aerators with dissolved oxygen (DO) control
- Implementation of detailed monitoring to include inflows, out flows, tank levels, and daily analysis of Chemical Oxygen Demand (COD), bio-mass concentration and other parameters



- Installation of a 70,000L secondary balance tank to help regulate flow from the clarifier into the bio-reactor
- Installation of Programmable Logic Controller (PLC) and other capital equipment including ultrasonic level sensors in all tanks
- Dosage of Biobac R200™ freeze-dried bacteria to establish and maintain an effective biomass.

As a result of this project, the treatment plant is producing excellent water quality, with COD results consistently below 10 mg/L. As a result, the business will save approximately \$1 million annually in trade waste costs and have reduced pollutant loadings to sewer by approximately 60 tonnes of COD per year.

Bottle Washer Case Study

Water recycling was implemented on a bottle washer for a system with a pre-rinse followed by three caustic and three water sections. The solution in the first caustic section of this system is filtered and recycled to this first section. In the third caustic (spray) section, an air fan was installed, to minimize the carryover of caustic to the warm water sections.

In the last rinsing section, rinsing was previously performed with three nozzles for the inside and one for the outside of the bottle. The rinsing at this line was modified to two inside spray nozzles operating with 7 kl/h fresh water. This rinse water is then collected, treated and used for one inside rinse and one outside rinse nozzle (overall, 7 kl/h). This rinse water is again collected and reused:

- first for a cold water bath
- second for a cold water rinse
- third for a warm water rinse
- finally for the pre-rinsing of the bottles

The treatment of the rinse water consists of a buffer tank, two parallel membrane filters of 5 µm and disinfection by UV lamps.

The fresh rinse water flow is adjusted according to the running of the bottle washer, presence of bottles, bottle speed, water level and temperature.

These measures resulted in a decrease of the specific water consumption (bottles of 1 and 1.5 l) from 0.6 to 0.4-0.5 l/bottle. The total fresh water consumption decreased from 39,590 to 23,960 kl/year and is equal to a water reduction of 39%.

3.3 | Warehousing

Not much water is used in the warehouse, with most being used only for cleaning purposes. Consider using water from final rinses or other clean streams from the brewery process for this application.

Make people aware of water wasting, as described earlier, and optimize the hoses used. In many cases, high pressure hoses, which use less water, can be used effectively in warehouse areas.

3.4 | Support Systems (Utilities)

Support systems include all utility and powerhouse operations. Often, water used for sanitary needs and outdoor landscaping is included in this category.

Best Practices - Cooling Towers

Evaporative cooling is a common and efficient way of dissipating thermal loads. Cooling towers and evaporative condensers require significant quantities of 'make-up' water to compensate for losses associated with evaporation, drift (or mist) and blowdown (or purge).

A key parameter used to evaluate cooling tower operation is "cycles of concentration" (sometimes referred to as cycles or concentration ratio). This is calculated as the ratio of the concentration of dissolved solids (or conductivity) in the blowdown water compared to the make-up water.

Cooling Towers⁷



Water use can be minimized by:

- Maximizing the cycles of concentration. Many systems operate at two to four cycles of concentration, while six cycles or more may be possible. Increasing the cycles from three to six will reduce cooling tower make-up water by 20%, and cooling tower blowdown by 50%
- Undertaking routine surveys of cooling towers and evaporative condensers for leaks and losses, and taking remedial action as soon as possible
- Repairing or replacing poorly operating blowdown valves promptly
- Checking overflows (e.g., make-up water tank) and ensuring they are not overflowing

Best Practices – Steam Generation

Boilers and steam generators consume varying amounts of water depending on the size of the system, the amount of steam used, and the amount of condensate returned.

Boilers⁹



The key to operating an efficient steam boiler is to maximize steam generation and minimize losses to sewer by:

- Inspecting the boiler, condensate system and steam traps to find and promptly repair leaks.
- Properly insulating steam and condensate pipes and hot well to decrease steam requirements and heat loss.
- Minimizing blowdown volumes by ensuring water treatment is optimized and blowdown automated.
- Ensuring condensate return is maximized and the system is working effectively. Recovering

condensate for re-use will reduce water use, chemical use and energy consumption.

Best Practices - Compressors

Refrigeration compressors often need cooling water. Since they produce excessive noise, these compressors tend to be isolated and only inspected when needed.

Compressor⁸



If possible, consider changing to a closed-loop system with a cooling tower, or otherwise, integrate the compressor cooling with another chilled water loop, like fermenting cooling. This chilled water loop is particularly effective when the brewery has several water cooled units. A small bleed will be needed for hygiene reasons.

If a closed-loop system is not possible, there may be a potential to reuse the water for various washing operations described earlier, like a cask washer or the CIP system. In this case, connect a solenoid valve to the cooling water supply to automatically cut off the supply when the compressor stops. Also install a frequency control to the pump of the cooling water supply to prevent manual tampering of the flow.

Air-Cooled Compressors

When replacing a water-cooled compressor, consider the use of an air-cooled unit to save water and during

cool ambient conditions, it may save energy as well.

Some (tank) radiators tend to accumulate ice due to humidity in the area. Do not use water to remove this ice. It will need an excessive amount of water and will increase the humidity even more. It is more efficient to use excessive heat or hot water or, in low peak hours, use electrical heating.

3.5 | Food Service

Many craft breweries include a brewpub within their operational footprint. In these instances, water and wastewater issues associated with food and drink services must be addressed. There have been a number of best practices identified for saving water in food service establishments. The National Restaurant Association has developed the Conserve Sustainability Education Program. It is an excellent online resource to help restaurants reduce operating expenses and leave a lighter footprint on the environment. Many of the ideas presented in this section are from the Conserve program.

Also check with your local water supplier for free water audits or rebates and incentives for restaurant water savings.

Top Water-Saving Opportunities For Restaurants/ Brewpub

- *Metering (control and predict your water use)*
- *Retrofit*
- *Use low-flow pre-rinse spray valves, faucets, toilets and urinals*
- *Add aerators*
- *Add insulation*

Water is a significant part of restaurant operations. It is used for cooking, cleaning, food production, customer consumption, and sometimes for landscaping. Conserving hot water is always a smart idea, because it trims two bills: water and the electricity or natural gas used to heat it.

A brewpub can be split into the kitchen area, the dining and restroom area and the outside of the brewpub (landscaping). Similar as with the brewing process, it all starts with some generic measures, like employee awareness and understanding water use.

Training employees on water usage and how they can contribute will help the understanding and acceptance

of measures.

Sierra Nevada Brewing Company Taproom Water Saving Projects

- *Replace Bathroom Faucet Aerators - 789,983 liters/year (immediate payback)*
- *Retrofit flush valve toilets w/ dual flush handles - 288,811 liters/year (0.7-year payback)*
- *Install Air-Cooled Ice Machine - 3,159,930 liters/year (1.5-year payback)*
- *Replace Pre-Rinse Spray Valves - 988,186 liters/year (immediate payback)*

Best Practices - Dishwashing

When cleaning dishes and plates, avoid using running water to thaw or rinse food. Instead, gradually thaw frozen food in a refrigerator. Wash vegetables in ponded water; do not let water run in preparation sink. Train employees to immediately scrape & wipe plates.

Use squeegee scrapers and avoid rags which soak water. Soak dirty pots and pans instead of rinsing them in running water. Pre-soak with sustainable cleansers, using baking soda to pre-soak pots and vinegar to cut grease.

Dishwasher Tips

- *Run fully loaded dish racks*
- *Pay attention to the pressure gauge - only 20 psi needed*
- *If conveyor-style dishwasher, make sure it's in auto mode*
- *Turn off at night and when idle for long periods of time*
- *Add or maintain wash curtains*
- *Repair leaks*
- *Replace worn spray heads*
- *Soak heavily soiled dishes*
- *Use heat exchangers (usually called an indirect exchanger - it's a plate heat exchanger so that the wastewater doesn't come in contact with incoming water)*
- *Check that water temperatures are between 120 to 130 degrees and the booster heater is used to reach 180 degrees if the dishwasher is high-temperature.*

Georgia Prison 'Cans' Excess Water Use

Problem: The Georgia Department of Corrections wanted to reduce daily water consumption at one of its prisons' cannery operations.

Solution: Diversifying the facility's cleanup and vegetable washing procedures reduced water use and energy costs.

Rogers State Prison (Reidsville, Ga.) is a little different than most prisons. As many as 130 inmates work each day at the facility's cannery, processing beans, carrots, peas, potatoes, squash, and greens. The vegetables are cultivated on prison grounds, and all the canned items are consumed by Georgia's prison inmates. In 2002, the plant produced almost 200,000 cases of vegetables; about 3.1 million kg (6.8 million lb) of food is canned at the facility annually.

The cannery gives the prisoners a productive outlet while saving taxpayers money. The process involves an excessive amount of water, however, so the Georgia Department of Corrections sought ways to minimize water use.

The department turned to Michael Brown, a senior research engineer at the Georgia Institute of Technology's Economic Development Institute (EDI);

Atlanta), and Judy Adler, a pollution prevention engineer at the Georgia Pollution Prevention Assistance Division (a division of the Georgia Department of Natural Resources), for help. The two began by gathering cannery supervisors and maintenance personnel for a brainstorming session.

Involving staff is crucial when seeking a solution to a facility problem, Adler said. "Employees that work at a facility day after day are the best resources for identifying water efficiency," she said. "Because employees are involved in the process from Day 1, brainstorming leads to buy-in of the chosen water efficiency alternatives."

Brown also visited the cannery over a 1-month period and measured all water applications and processes at the site. Using these data and the brainstorming results, cannery supervisors and maintenance staff determined where water use could be cut

and devised strategies to do so.

"Approximately 25% of the water used was going to washing the floors," Brown said. "This was being done by using hoses as a broom. Through facilitated sessions, we determined we could save about 90% of water usage per day for this task by having the cannery maintenance staff do 'dry clean-up' using shovels, squeegees, and brooms to push solid waste into the floor drain."

Another water-conserving measure, Brown said, was limiting the use of freshwater rinsing during canning.

"Inmates were rinsing the vegetables with freshwater during all three stages of cleaning," Brown said. "Now only the end phase uses freshwater, with the other two stages using reused water. This 'counterflow rinsing system' not only reduces spills and overflows, but also saves approximately two-thirds of the water usage per day for this task."

Cannery maintenance supervisor Gary Brown planned, designed, and built the counterflow rinsing system after initially presenting the idea at the brainstorming session and receiving guidance from the University of Georgia (Athens) Food Science Department about its safety. The system takes the discharge from the last rinsing station and uses it upstream as the feed water for earlier rinsing stages.

The results of such creativity and ingenuity have had widespread positive effects on the facility, according to supervisory and maintenance staff. "These ideas save dollars and energy all around," Brown said. "For instance, we're saving the cost of electricity used to pump water and costs to treat water that runs into the treatment plant. Also, we're in the process of carrying over and imple-

menting the water conservation ideas we're using in the cannery plant at the prison's meat processing plant and dairy."

Approximately \$38,000 in capital costs was required to implement five series of recommendations. The money was spent on flowmeters, totalizers, and control valves; a dry cleanup system; the counterflow rinsing system; the elimination of water in a 'big chain' washer; and a pea cooling system.

An EDI study of these changes determined that the cannery's water use reduction strategies are saving approximately 91,000 m³ (24 million gal) of water and \$102,000 per year.

For more information, contact Michael Brown at (912) 963-2520 or mike.brown@edi.gatech.edu.

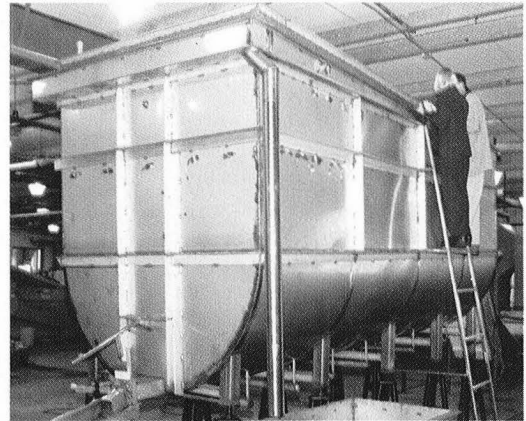

Mike Brown recommended improving the "pea cooling system" by replacing the current ice cooling with recirculated chilled water. Using chilled water eliminates the need to purchase 33,000 lb of ice each year. Pea cooling is used to prevent spoilage prior to canning. Pictured are P2AD's Judy Adler and DOC staff engineer Kirk Mays.



North Carolina Cooperative Extension Service



**Water Quality &
Waste Management**

Pollution Prevention Pays in Food Processing

Reducing Water Use and Wastewater in Food Processing Plants

How One Company Cut Costs

Prepared by:

Roy E. Carawan

Food Science Extension Specialist

North Carolina State University

Last Electronic Revision: March 1996 (JWM), 11/7/96 by Ronald Lee Still

Many food processing plants today are literally washing profits down the drain. This industry typically uses a large volume of water to process food products and clean plant equipment, yielding large amounts of wastewater that must be treated. Excessive water use and wastewater production adds financial and ecological burdens to the industry and to the environment. However, food processors can take actions that will dramatically reduce water use, wastewater production, and the high costs associated with these problems.

Using water for cleanup in food processing plants flushes loose meat, blood, soluble protein, inorganic particles, and other food waste to the sewer. Some of these raw materials could be recovered and sold to other industries, but instead are lost. Also, most of this waste adds a high level of biochemical oxygen demand (BOD₅) to the wastewater.

Wastewater treatment plants use BOD₅ levels to gauge the amount of waste that is present in water - the higher the BOD₅ level, the more treatment this wastewater will require. Sewer plants add surcharges for each pound of BOD₅ that exceeds a set limit. These charges can cost the company hundreds of thousands of dollars each year.

Food processing companies can benefit by learning about current methods and interventions that can assist in effectively managing their water resources. Without the appropriate knowledge and use of these wastewater management techniques, these companies will continue to lose money through water use charges, raw material losses, sewage surcharges, and possible fines from environmental agencies. With the public emphasis on environmental quality, the food industry has further incentive to reduce its water usage and its wastewater production.

This publication discusses how one food processing company became aware of its wastewater problems and reduced costly waste with assistance from the North Carolina Cooperative Extension Service and the North Carolina Pollution

Prevention Program. By implementing a comprehensive water management and waste reduction program, the Equity Group has dramatically reduced its BOD₅ production by 77 percent and its water use by 30 percent (Table 1).

Measure	Before	Now	Goal
Water Use (gal/month)	4,250,000	3,000,000	2,000,000
Waste Loads-BOD ₅ (lb/day)	4,500	1,000	500
Landfill Disposal (tons/wk) (Scrap, inedible product)	30	0	0
Animal Food Collection (tons/wk)	0	50	80
Dry Cleanup Pollution Prevented (lb BOD ₅ /day)	0	2,200	2,500

Background

The Equity Group, a division of Keystone Foods, built a food processing plant in 1980. Each day, at the time its waste reduction program was developed, the facility produced around 2.5 million chicken nuggets for the southeastern McDonald's restaurants. These nuggets are formed from high-quality chicken breast and thigh meat. Chicken meat is ground, blended, formed, battered, breaded (Tempura), fried, frozen, and then packaged. This process is shown in Figure 1.

Figure 1. Nugget Line

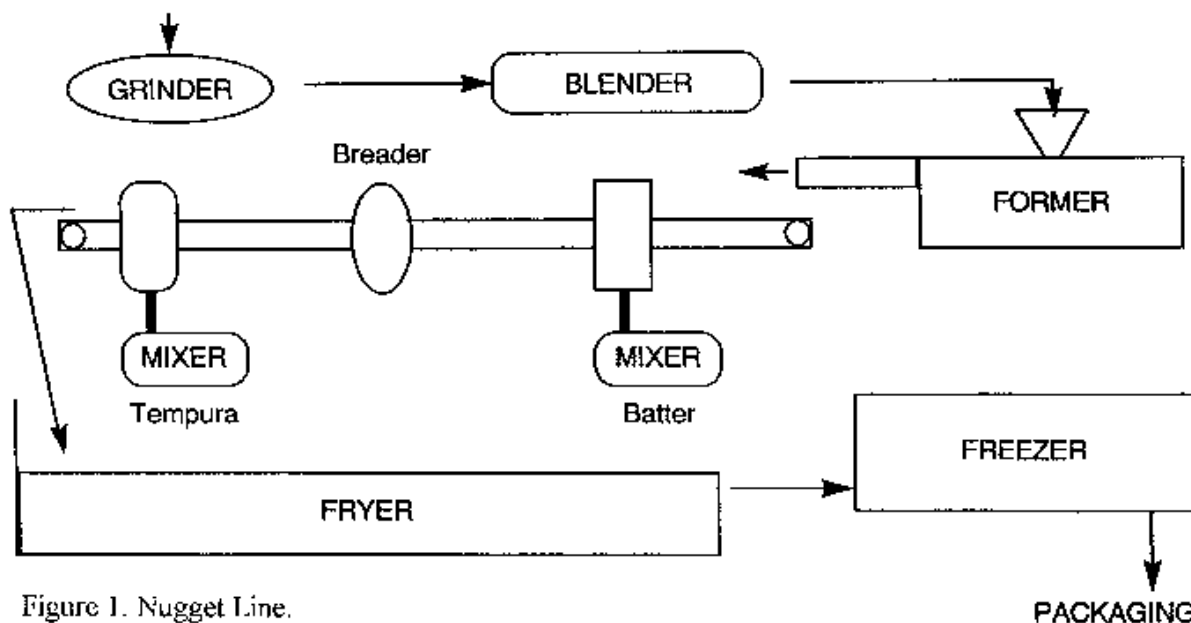

Figure 1. Nugget Line.

The plant, which operates five to six days a week, used almost 200,000 gallons of water per day (Table 2). The company employs 275 people in two production shifts and one cleanup shift. When the problem of waste management was first approached, this company was discharging around 4,500 pounds of BOD₅ per day.

Table 2. Equity, Reidsville Facility

- Water use: Almost 200,000 gal/water per day
- BOD₅ Load: 4,500 lb/day
- Two production shifts; one cleanup shift
- 2,500,000 nuggets per day
- 275 employees

The problem

The Equity Group meat plant is required to meet stringent production and sanitation standards that result in high water usage in order to maintain high product quality. When the U.S. Department of Agriculture (USDA) implemented a requirement that the production lines be free of meat accumulation at all times, workers found they needed to hose the equipment three times per shift. Consequently, water use and waste production increased tenfold. Since Equity was not operating under a strict waste load reduction program, many pounds of organic material were flushed to the sewer and directed to the company's pretreatment plant. An average of 55 pounds of meat, 3 pounds of tempura, and 15 pounds of dry batter per line were being lost from each of the seven lines to the sewer on each shift.

At about this same time, the City of Reidsville ran into problems with its wastewater treatment plant when it was fined by the state for polluting Little Troublesome Creek. Investigations revealed that the city's system was incapable of processing all of the pretreated wastewater discharged by Equity's processing plant. The city then set a BOD₅ limit on this pretreated wastewater and imposed heavy surcharges for BOD₅ levels that exceeded the limit

Management forms a task force

Equity was notified of the city's sewage system problems and of the increased charges for treating waste-water containing high levels of BOD₅. The company took immediate action by appointing an in-house task force to explore ways to reduce the plant's waste and effectively manage its water use. The director of personnel for the company was designated to head Equity's task force. By selecting a manager familiar with human relations to lead the committee, Equity placed a strong emphasis on developing programs that would enhance employee attitudes toward waste reduction. To make changes in procedures, equipment use, and maintenance practices, the company would need its employees to fully understand and support new waste-reduction techniques.

The Equity task force contacted specialists at the Cooperative Extension Service who, in turn, called in an engineer from Pollution Prevention Program of the North Carolina Department of Environment and Natural Resources.

The Equity Group applied for and received a Challenge Grant from the NC Pollution Prevention Program (PPP) for use in developing its water and waste reduction programs. These grants are awarded to help businesses and communities develop waste reduction programs. The concept of PPP is to attack pollution at its source by reducing the amount of waste created rather than trying to correct the problem through wastewater treatment.

The problem is addressed with the PPP concept

Equity's task force met with Pollution Prevention Program representatives, Extension Service specialists, and Reidsville city officials to analyze the wastewater problems the company and the city faced and to explore possible solutions. To reduce Equity's problem, the task force and specialists took the following steps based on the PPP concept of waste prevention:

1. Provided education on water use and waste load;
2. Surveyed the plant for problem areas;
3. Evaluated plant processes;
4. Promoted the use of dry cleanup;
5. Provided for waste recovery and utilization;
6. Enhanced waste pretreatment.

These steps are discussed in the following sections.

1. Education is first and foremost

The most critical step was to educate the plant's managers and employees. Few of them realized the importance of waste and water control. No one understood how much water was used and how much waste was generated. Managers just did not realize the daily cost of a careless approach to waste management and water use.

Managers provided the incentive for employees to become informed and to take action in Equity's waste-water reduction program. When the managers showed a genuine concern and commitment for reducing water use and waste production, the employees were motivated to become involved as well. Providing education on the causes and effects of high water use and wastewater production also raised employees' social consciousness.

Today's public is greatly concerned about the environment. If a company does not show equal concern, it may find itself with a public relations problem. Fortunately, all of Equity's managers were concerned and prepared to address their problems openly. Remarking on reports identifying the areas of waste production and heavy water use, Jerry Gotro, Equity's vice president, said, "This is not a slap on the hand. No one is to be ashamed of what the report states. On the other hand, everyone will need to be 150 percent dedicated and involved in the ultimate solution." This type of attitude in the industry is ultimately conveyed to the public and promotes a positive outlook from the community.

2. Initial survey identifies dry cleanup as an opportunity

A plant survey determined where water use occurred and where wastes were generated in this food processing plant. The results showed that over half of the waste load resulted from wet cleanup practices. Waste in the form of batter, tempura, bits of chicken, juice, blood, fat, and nugget pieces was being flushed down the drains.

Specialists were called in to analyze the cleanup process and make recommendations. Drawing on the PPP concept of waste prevention, these specialists suggested techniques for dry cleanup (discussed in Section 4) that would reduce wastewater production. In dry cleanup, methods are used to capture all nonliquid waste and prevent it from entering the wastewater. Part of the Challenge Grant was used to develop a training program for the cleanup crew based on these recommendations.

3. Further evaluation of plant processes

Some of Equity's other waste production problems called for further evaluation of the plant's processes. Equity discovered that it had insufficient waste collection equipment, leaks in some machinery, and worn-out equipment and lines. Also, employees, unaware of Equity's water use and wastewater problems, were hosing most waste down the drain without attempting to pick it up and dispose of it in a "dry" manner. The task force conducted another plant survey of the possible causes of waste loss to the sewer. The chart on the next page lists the problems identified and the recommended solutions.

Equity also noted the need to revise sanitation procedures and to look into selling waste materials to animal feed producers.

4. Dry cleanup is pursued

Systems have been installed for collecting and disposing of drips and batters to help keep waste production down. Also, employees are instructed to remove all dry waste from the floor and the equipment before cleaning with water. Just by changing to dry cleanup methods, Equity has reduced BOD₅ levels in this plant by 50 percent.

5. Residual waste recovery and utilization

Most of the waste that comes out of the plant consists of carbohydrates or proteins. With dry cleanup, much of the waste is reclaimed and put to secondary use. Part of the "waste" collected during dry cleanup is shipped to a company in Atlanta to use for animal food. This material totals over 5 million pounds per year. The remaining waste from dry cleanup is sold to a renderer. Other ideas for the use and disposal of waste are presented in Table 3.

Table 3. Possible Utilization or Disposal of Food Plant Residues	
Idea Utilization or Disposal Method	
1.	Direct uses: animal food
2.	Install dryer to prepare animal food
3.	Install or utilize incineration
4.	Send to landfill
5.	Contact recoverers
	o Renderers
	o Grain product

6. Pretreatment is the last line of defense

A grease trap, solids recovery basin, and an activated sludge system with provisions for pH control were in place before the current problems surfaced. Although the activated sludge system was not operating at its optimum level, even under ideal conditions it was not capable of significantly reducing BOD₅ levels. Nevertheless, as part of a total management approach, Keystone Foods corporate engineers removed the grease trap and solids recovery basin, and they enhanced the activated sludge basin with additional aeration. A dissolved air flotation system and a belt filter press, along with the enhanced basin, are now being used with promising results. Equity's modified pretreatment facilities are shown in Figure 2. A brick building was constructed to house the aeration basin, belt filter press, and system controls. The building was designed to conceal the system and to contain odors that had been a problem. The odors were eliminated by passing the building's exhaust air through a wet scrubber.

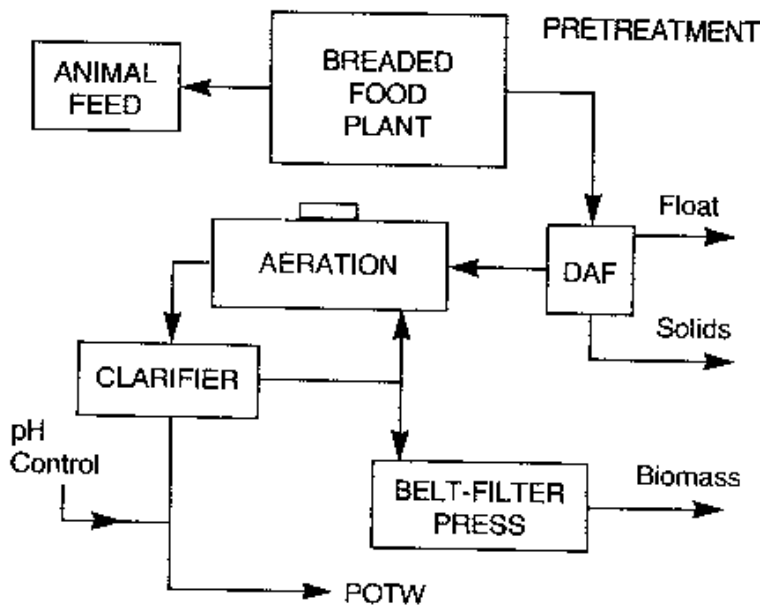

Figure 2. Waste Flowchart.

the city sewage treatment plant. Most of the changes made to reduce water use and waste cost the company little or nothing. Carelessness, a costly trait for any business, was prevented simply by focusing employee awareness and management emphasis on the problem. Common-sense approaches to cleanup, such as using trays beneath machines to catch spillage, picking up spillage before hosing down the floors, and placing screens over drains, were used at little cost. Awareness of the serious problems caused by reckless water use and product waste cost the company nothing but the time needed to educate employees thoroughly. After all new procedures had been implemented and preliminary training completed, it was found necessary to conduct a detailed training course for each line. A successful pollution prevention program requires frequent retraining to keep employees focused and vigilant.

Ensuring that pretreatment facilities are operating effectively is important to managing wastewater production. However, dry cleanup, proper equipment utilization, and employee awareness seem to be the most effective and economical forms of pretreatment.

Controlling wastewater is highly cost effective

A concept as simple as keeping wastes off the floors and out of the drains will save this company many thousands of dollars per year and reduce the strain on

Problems and Recommended Solutions			
Problem 1	The equipment used to produce the nuggets	Problem 3	The employees, although conscious of the problems, were

	rendered heavy waste in the plunger area, the batterer, tempura containers, and mixers.		not properly trained to handle them.
Recommendation	<ul style="list-style-type: none"> • Repair or replace specified equipment. 	Recommendations	<ul style="list-style-type: none"> • Hire employees specifically for supervising floor and equipment waste pickup and separation of solids, liquids, and breadding for both the first and second shifts. • Train and educate all employees, especially those in cleanup, as to the seriousness of the situation and the proper procedures for efficient cleaning. • Produce a videotape for training purposes. • Emphasize minimum water usage to all employees and management.
Problem 2	The containment trays and devices were insufficient, required maintenance, and needed to be redesigned.	Problem 4	There was a serious lack of communication among company directors.
Recommendation	<ul style="list-style-type: none"> • Obtain the specified equipment needed to reduce waste lost to the floor, such as trays under breaders to catch spillage. 	Recommendations	<ul style="list-style-type: none"> • Improve communication among directors, management, and employees. • Present specific areas of plant losses (such as where breadding is spilled). • Encourage employees to express new ideas for water use and waste reduction to their supervisors.

The Equity Group has shown that it is possible to reduce the BOD₅ level by over 50 percent using dry cleanup alone. Overall, the company expects up to a 90 percent reduction in its waste load. Priorities and changes that were used to bring about Equity's significant success appear in Table 4.

Table 4. Prioritized List for Waste Control	
Priority Change Required	
<ul style="list-style-type: none"> • 1. Management attitude is the key. • 2. Think "wild" - look at all ideas. • 3. Listen to everyone - the employees may already have a solution. • 4. Look for help from associations, 	<ul style="list-style-type: none"> • 6. Employee attitudes are important. Employees must understand that without success the plant may have to close • 7. Note that "water, water everywhere" is not the way of business anymore. • 8. Contain wet wastes.

- friends, and agencies.
- 5. Identify your problem and note the problem areas.

- 9. Control dry waste.
- 10. Look not only at the costs but also at the savings. Begin a new way of life.

Cost savings resulted from a reduction in water costs, sewage surcharges, and expenditures for product and ingredients. Savings exceeded \$100,000 annually, without taking into account the savings realized by avoiding the proposed surcharge costs, which would have exceeded \$200,000 annually. Equity also saves by selling to renderers the solids recovered from the dissolved air flotation system and the belt filter press. Since more waste is reclaimed rather than released through waste-water, less pretreatment is necessary, holding costs down. If the program had not been successful, a \$1.5-million-dollar expansion of the pretreatment system would have been necessary, in addition to system modifications made, which cost about \$500,000. Operating costs for the expanded system would have exceeded \$100,000 annually.

Continuing to try new ideas

Equity managers are continuing to test and implement new ideas that may save water and reduce waste-water production:

- They have designated one of their production lines as an exemplary line. The maintenance crew regularly upgrades equipment parts, seals all leaks, tightens nuts and bolts, and replaces containment trays as needed to prevent spills.
- A "waste awareness program," or WAP, has been initiated to involve employees directly in waste reduction efforts. Under this program, employees form a WAP committee that meets monthly to focus on specific waste reduction issues or problems. The committee encourages employees to bring problems to its attention by offering one day off with pay for the best idea of the month. Employees form teams that meet weekly to help implement the solutions suggested by the WAP committee. Employees serve on the committee and teams in rotation so that everyone has a chance to share this experience.
- To keep employees aware of the need for waste reduction and focused on preventing pollution, frequent retraining sessions are conducted. Equity's managers found that the effectiveness of the waste reduction measures implemented in the plant diminished with time. Two years after the program began, waste production had again increased and surcharges had reached more than \$11,000 per month. Realizing the need to keep awareness and commitment high, managers initiated a detailed, shift-by-shift training program to train new employees and retrain the others. The results were gratifying: waste production declined enough to reduce surcharges from \$11,000 to an average of only \$39 per month.

The Equity Group demonstrated not only good social consciousness in working to reduce the waste it was sending to Reidsville's sewage treatment plant, but also good business sense in reducing water costs, waste removal costs, and finding creative ways to use its waste for the company's and society's benefit.

This publication was supported in part by the North Carolina Board of Science and Technology in cooperation with the North Carolina Pollution Prevention Pays Program.

Published by North Carolina Cooperative Extension Service

Publication Number: CD-35

North Carolina State University at Raleigh, North Carolina Agricultural and Technical State University at Greensboro, and the U.S. Department of Agriculture, cooperating. Distributed in furtherance of the Acts of Congress of May 8 and June 30, 1914. The North Carolina Cooperative Extension Service is an equal opportunity/affirmative action employer. Its programs, activities, and employment practices are available to all people regardless of race, color, religion, sex,

age, national origin, handicap, or political affiliation.

Water Conservation

Conserving water can provide substantial energy savings and benefit the environment. A mid-sized poultry processor embarked on a water reduction program that involved reducing water consumption throughout the production process. The program cut usage by 57,000,000 gallons per year and is saving \$102,000 annually. Consider these water efficiency measures:

- ◆ Recycling and reusing water wherever possible
- ◆ Installing an ultrafiltration/reverse osmosis filtration system or ion-exchange closed-loop system
- ◆ Treating and recycling process brines by reverse osmosis
- ◆ Adding sideboards or splash guards to prevent spillage
- ◆ Switching from a continuous to a counter-flow rinsing system

Heat Recovery

Recovering waste heat from equipment and other sources can provide capital for other plant improvements. A major wholesale bakery installed a waste heat recovery system, an energy-efficient electric freezing system, and other efficiency improvements. This equipment eliminated the need to use carbon dioxide in the freezing process, reducing the bakery's carbon dioxide emissions by 7 million pounds each year and cutting energy costs by \$253,000 annually. Your company may want to take advantage of these waste heat recovery opportunities:

- ◆ Using cooker (retort) condensate to preheat topping water
- ◆ Directing waste heat from refrigeration compressors to preheat water for defrosting
- ◆ Using boiler blowdown to preheat feedwater to the boiler
- ◆ Using hot process fluids to preheat incoming process fluids

Heat Containment

In some cases, heat containment may be the preferred approach. Containing heat can help you prevent energy loss in production operations and may contribute to more comfortable working conditions for employees. Even small-size companies can realize significant benefits. For example, a 100-employee frozen food producer achieved annual energy savings of 600 million Btu and \$11,000 by insulating baking ovens and boilers. Consider the following additional actions:

- ◆ Insulating baking ovens and process equipment
- ◆ Insulating steam lines and boilers
- ◆ Installing process pipe insulation
- ◆ Repairing and eliminating leaks in steam lines and valves
- ◆ Covering open tanks

Air Compressors

Improving compressed air systems can significantly reduce operating costs while optimizing system performance. By raising the suction temperature and lowering the discharge pressure on its compressors, a small dairy products manufacturer realized annual energy savings of 1.500 million Btu and \$12,000. Ensure that compressed air systems operate efficiently by:

- ◆ Fixing leaks
- ◆ Selecting the proper size compressors for the application
- ◆ Setting compression levels no higher than needed
- ◆ Removing or closing off unneeded compressed air lines
- ◆ Using compressor air filters

As of March 1996, Climate Wise Partners in the food industry include:

Del Monte Foods

Maui Pineapple Co., Ltd.

Liquid Sugars, Inc.

Pacific Coast Producers

Tri Valley Growers

Hudson Specialty Foods

Weaver Potato Chip Co., Inc.

▼

**To find out how
Climate Wise
can assist you in
developing an
energy efficiency
and pollution
prevention
strategy,
contact one of
the co-directors
listed on
the front**

▲



4.2 Technical, Financial Feasibility and Potential Water Use Efficiency Improvements for BMPs and Audits

The Legislature called upon the CII Task Force to develop “an assessment of the potential statewide water use efficiency improvement in the commercial, industrial, and institutional sectors that would result from implementation of these best management practices” (CWC Section 10608.43). A statewide assessment was challenging, as described in this section, but examples of water savings accomplished in specific applications are presented in this section along with an approach based on penetration rate for a BMP.

Finally, water audits have been found to be effective in assisting managers of CII entities to identify areas of inefficient water use within facilities and appropriate BMPs to reduce water use. A discussion of audits concludes this section.

Recommendations

The CII Task Force has the following recommendations based on the background information provided in Section 6.0 of Volume I and II.

- CII entities should perform water audits to identify opportunities for implementation of BMPs.
- Following audits, CII entities should evaluate the technical and financial feasibility of BMPs to determine whether to implement BMPs.
- Water and energy service providers should incorporate water audits into their efficiency programs, consider financial incentives for BMP implementation, and provide other technical assistance as appropriate.
- Organizations representing businesses and industry, water service providers, CUWCC, and DWR should educate CII businesses on the BMPs and approaches to doing audits and performing a cost-effectiveness analysis.
- All new water users should consider implementing the recommended BMPs at the time of installation or construction.
- When replacing equipment, CII business should evaluate the equipment and the maintenance and operational practices needed to achieve an industry standard of water use efficiency for the new equipment being purchased.

This section is more completely summarized in Section 6.0 of Volume I with a more detailed description in Section 6.0 of Volume II and begins with CII Task Force recommendations.

4.3 Best Management Practices

A wide range of BMPs have been developed that focus on technical advancements and improved management practices that will increase the efficiency of water use in the CII sectors. A detailed discussion on specific BMPs that could be implemented for the various CII sectors and their financial feasibility and potential water efficiency improvements are described in Volume I, Sections 6.0 and 7.0 and Volume II, Sections 6.0 and 7.0 and Appendix A.

Implementation of the BMPs could be facilitated by all stakeholders doing the following:

- Endorse and adopt a formal process and commit to ongoing support for CII water conservation measures to address issues identified in this report.
- Share and promote the importance of BMP implementation with CII businesses and the general public.
- Conduct state-wide BMP workshops in coordination with industry organizations to implement the recommendations of this report;
- Provide technical and financial assistance and advice to those implementing the BMPs.
- Develop a mechanism for reporting progress that could include:
 - Periodic reports to the Legislature through DWR or other designated entities
 - Inclusion of progress reports in CUWCC reports to the State Water Resources Control Board (SWRCB)
 - Inclusion of progress reports in urban water service supplier Urban Water Management Plans (UWMPs)
- Develop local, sector specific, and state wide approaches to track the success and effectiveness of BMP implementation efforts and water savings results.
- Develop a mechanism to update the CII BMPs as practices and technologies improve.
- Identify assurance mechanisms that recommendations of this report are addressed.

It is recommended that an advisory group or committee be formed to further analyze and make recommendations regarding the development, use, and capture of pertinent metrics and BMPs.

Water service providers (and energy utilities) should incorporate audits into their efficiency programs, consider financial incentives for BMP implementation, and provide other technical assistance as appropriate.

Financial Feasibility and Potential Water Use Savings for BMPs:

- CII businesses should perform audits to identify opportunities for implementing BMPs. Following audits, they should calculate the cost-effectiveness of various measures, factors such as:
 - Projected water and wastewater cost savings over time
 - Energy savings and changes in operation and maintenance costs including changes in water, wastewater, energy, waste disposal, pre-treatment, chemical, and labor costs
 - Implementation cost
 - Potential incentives available
 - Water supply reliability benefits
- Water service providers (and energy utilities) should incorporate audits into their efficiency programs, consider financial incentives for BMP implementation, and provide other technical assistance as appropriate.

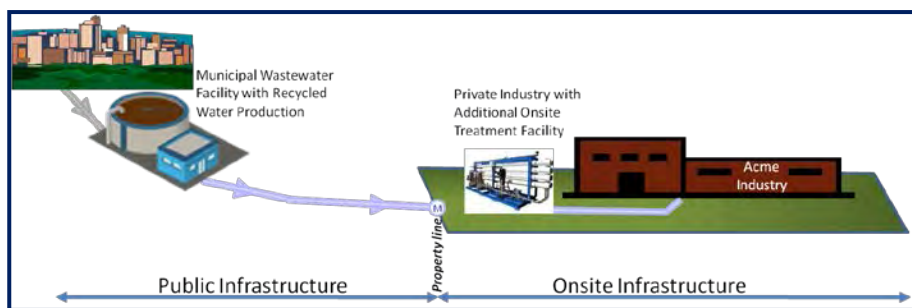

The CUWCC should continue to update their BMPs for water service providers' CII conservation programs and technologies to incorporate the CII BMPs, audits, and cost-effectiveness assessments. All new water users should also consider and re-evaluate implementation of recommended BMPs at the time of equipment installation or construction improvements.

4.4 Recycled Water and Alternative Supplies

Key issues in the CII Task Force Report address how non-potable water sources can be obtained and incorporated into CII applications. These issues are considered in Sections 7.0 (alternate water supplies and specific BMPs), Section 9.0 (infrastructure limitations for obtaining municipal recycled water), and Section 10.0 (barriers and solutions for CII use of municipal recycled water). Overall these recommendations include legislative, financial, regulatory, and operational mechanisms for increasing non-potable water use in CII applications.

The following actions should be taken to encourage more aggressive use of recycled water and alternative water supplies by CII water users:

6.4.1 Potential Statewide Water Use Efficiency Improvement

A number of factors are involved in assessing the potential statewide water use efficiency improvement in the CII sectors that would result from BMP implementation:

- Savings potential from application of an individual BMP.
- Existing penetration levels of a BMP, that is, the degree of current use of a BMP.
- The penetration potential of a BMP, the maximum potential applications of a BMP where it would be cost-effective.
- The total water use in particular CII sectors or subsectors or in particular common CII processes where a BMP would be used, to assess water use efficiency improvement.

As has been emphasized in Section 5.0, Water Use Metrics and Data Collection, the State does not currently have the data necessary to establish baseline water use in each CII sector or subsector. Because of the variability of process designs and the number of potential applications of particular BMPs (penetration potential), the CII Task Force could not estimate the potential water savings statewide for most BMPs. One of the major objectives of section 5.0 is to suggest the use of metrics and better data collection to begin making statewide assessments of CII water use efficiency improvements over time and to provide comparative data that CII entities can use to assess their efficiencies relative to other similar entities. In most cases, the information needed to estimate statewide savings must await the development of the baselines and metrics recommended in this report.

6.4.2 Examples of Potential Water Savings from BMPs

Demonstrating water savings that have actually occurred from implementing BMPs has been an easier task where data have been collected or maintained by water service providers or individual CII entities. Two examples of statewide achievement illustrate what such analysis has to offer. The first statewide example is the California Department of Corrections and Rehabilitation (CDCR), which is described in Section 7.1.6, Prisons and Correctional Facilities of this report. CDCR has already realized a 21 percent reduction totaling over 2.4 billion gallons of water annually (7,365 acre-feet annually). The second example is found in the Section 9.0, Public Infrastructure Needs for Recycled Water. Based on a statewide survey of 2009 recycled water use, almost 670,000 acre feet (af) (218 billion gallons) of water are being recycled annually, of which 224,700 AF of recycled water were used directly in CII applications.

Numerous examples to illustrate potential water savings are described in Section 7.0 on BMPs and in case studies in Appendix C. The reader is urged to read these examples and case studies to assess how BMPs might benefit a particular CII entity.

The BMPs may involve a range of implementation approaches from maintenance adjustments and equipment replacement to alternative water supply use. Five such approaches are illustrated below.

1. **Adjustment of equipment and repair of leaks**

Adjustments and repairs can be made to existing equipment and processes so that they operate more efficiently. For example, in Section 7.3.6 General Building Sanitation, an example is given of the Park 55 Wyndham Hotel in downtown San Francisco. Its toilet retrofit resulted in a more water savings than expected based on "engineering" estimates because leaks and faulty equipment were also fixed. In another example, Eagle Food in Sun Valley, California audited its facility and implemented the following measures:

- Restrict water flow at hose stands – Eagle Foods installed flow control valves to reduce water flow from 7.5 gallons per minute (gpm) to 3.5 gpm.
- Use water brooms instead of hoses to wash down for sanitary purposes.
- Install hose bib connectors to reduce leakage at water tanks.
- Replace cracked hoses as needed to reduce leakage.

The first two measures are examples of modifying or installing more efficient equipment, and the last two measures reduced leaks. The combination of measures resulted in savings of nearly 7,264 gallons per day (see Eagle Foods case study in Appendix C).

2. **Modification of equipment or installation of water saving devices and controls**

Devices, automated systems, or equipment can be added to existing water using equipment and processes. For example, the Los Angeles County, Department of Parks and Recreation installed weather based controllers, rain sensors, and a monitoring system at its El Cariso Park & Golf Course and Veterans Park. This resulted in a 27 percent reduction in water use equivalent to 198 AF (64.5 million gallons) a year.

Artistic Plating and Metal Finishing, Inc. of Anaheim, California installed electrode-less conductivity controllers on nine tanks on the plating line. This reduced water use by 49 percent and also reduced chemical costs by 20 percent. The total cost for these improvements was

\$14,500, however, because it saves \$13,800 per year, the payback is only 13 months.

3. **Replacement with more efficient equipment**

Replacing older inefficient water-using equipment and fixtures with water saving types of equipment is one of the most recognized ways to reduce water use. For example, in the General Building Sanitation section of this report, an estimate of total potential statewide water savings that could result from the replacement of existing CII toilets with high-efficiency toilets was made in 2005. That analysis estimated the water savings potential as being between 26,000 and 38,000 acre-feet per year (AFY). Another 3,000 to 5,000 AFY could be saved through legislation, codes, and standards applied to new construction. In a similar manner, installing a clean in place (CIP) system in a food processing plant can cut the water use by half for washing pipes and vessels.

4. **Alternative water supplies and internal recycling**

There are many examples of using treated municipal wastewater in California showing the potential for using this non-potable water source, as described in Section 9.0. Examples of other alternative supplies range from the low impact stormwater management options being used in San Diego County, California to rainwater harvesting and air conditioning condensate recovery throughout the United States. The food processing industry also has many examples of reusing effluent for crop irrigation. Recycling of water in cooling towers is also common reuse of water.

5. **Change to waterless process**

There are many examples of BMPs where water using equipment is replaced with equipment that does not use water. From section 7.3.3 Thermodynamic Processes in this report, using air cooling and ground effect (geothermal) air conditioning systems eliminates cooling tower water use entirely. In conventional cooling towers, approximately 2.5 gallons of water are used per ton-hour of cooling. A large office building with a cooling tower can require 20,000 to 30,000 gallons of water per day during the hottest part of the summer.

The use of dry vacuum pumps in laboratories and medical facilities offers another waterless process example. In recent years, most major radiology departments in hospitals have converted to digital imaging because of its superior medical diagnostic capabilities, eliminating water used by large plate X-ray film development. This can save as much as 500,000 gallons of water per year per film developer.

Beverage Manufacturers

The beverage industry uses a wide variety of processes to make and package such products as beer, milk, wine, soft drinks, and fruit juices. Water quality and purity are of primary concern, since water is usually a major component of the consumed products. Water is also used to clean and sanitize floors, processing equipment, containers, vessels, and the raw food products. Some older bottling plants use more water for cleaning than for product. With current technologies, one can design and build a facility that has a reduced requirement for water. **PROC**

Standards and Practices

Principles include the following:

- ◆ provide adequate metering, including submetering, at all major water-using areas and for process control.
- ◆ design the facility for ease of cleaning.
- ◆ take advantage of dry methods for cleanup and transport.
- ◆ use product and by-product recovery systems.
- ◆ consider all possible opportunities for water recovery and reuse and for alternative water supplies, such as filtration and membrane processes and capturing condensate drain water from air-conditioning and refrigeration systems. **ALT 4**
- ◆ design for minimal or no water use. **PROC**

Larger equipment that cannot be disassembled easily must be cleaned and sanitized in place. Use pigging as part of the clean-in-place system for process pipes. **PROC**

Water Treatment

Water is softened and mixed with biocides and soaps before it is sprayed onto conveyors, so cans and bottles can “slip” easily on the high-speed conveyor belts and not tip over. To minimize the use of and need for water-lubricated conveyor belts, ensure that the spray nozzles are properly sized, well-aligned, and equipped with automatic shutoffs. **PROC**

Beverages range from milk and fruit juice to wine and beer. Water quality is important, since water is often a component of the consumed product, in addition to its use in the manufacturing process.

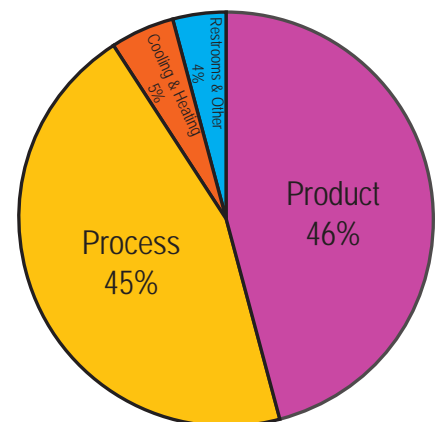

Typical water uses in beverage manufacturing



Water Reuse and Recycling

Water is used as a heat-transfer agent in a variety of applications. This water remains relatively clean and is an excellent source of water for reuse. **PROC**

Heating Systems

Steam boilers and hot-water boilers provide heat and hot water for many purposes. Closed-loop systems return water and steam condensate to the boiler for reuse, saving energy and water. Open-loop systems expend the water or steam without return to the boiler. Several water-efficiency choices are available:

- ◆ steam boilers of 200 boiler horsepower (hp) or greater, equipped with conductivity controllers to regulate top blowdown.
- ◆ for closed-loop systems, condensate-return meters on steam boilers of 200 boiler hp or greater.
- ◆ closed-loop steam systems operating at twenty cycles of concentration or greater (5 percent or less of makeup water) where chemistry of the water allows.

Closed-loop systems save water and energy.

TIP: Conspicuously mark fire-protection plumbing so no connections will be made except for fire protection. Additionally, install flow-detection meters on fire services to indicate unauthorized water flows. **REST**



Kennedy/Jenks Consultants
Engineers & Scientists

Kennedy/Jenks Consultants
303 Second Street, Suite 300 South
San Francisco, California 94107
415-243-2150



Brown & Caldwell
1590 Drew Avenue, Suite 210
Davis, California 95618
530-747-0650