

# *Rotoplas 2014*

## *Semi-Automated Dosing Systems for Powder Delivery to Molds*



**Jim Hummel,  
Powder King**



**Harry Covington,  
Ferry Industries, Inc.**

# *System Overview*

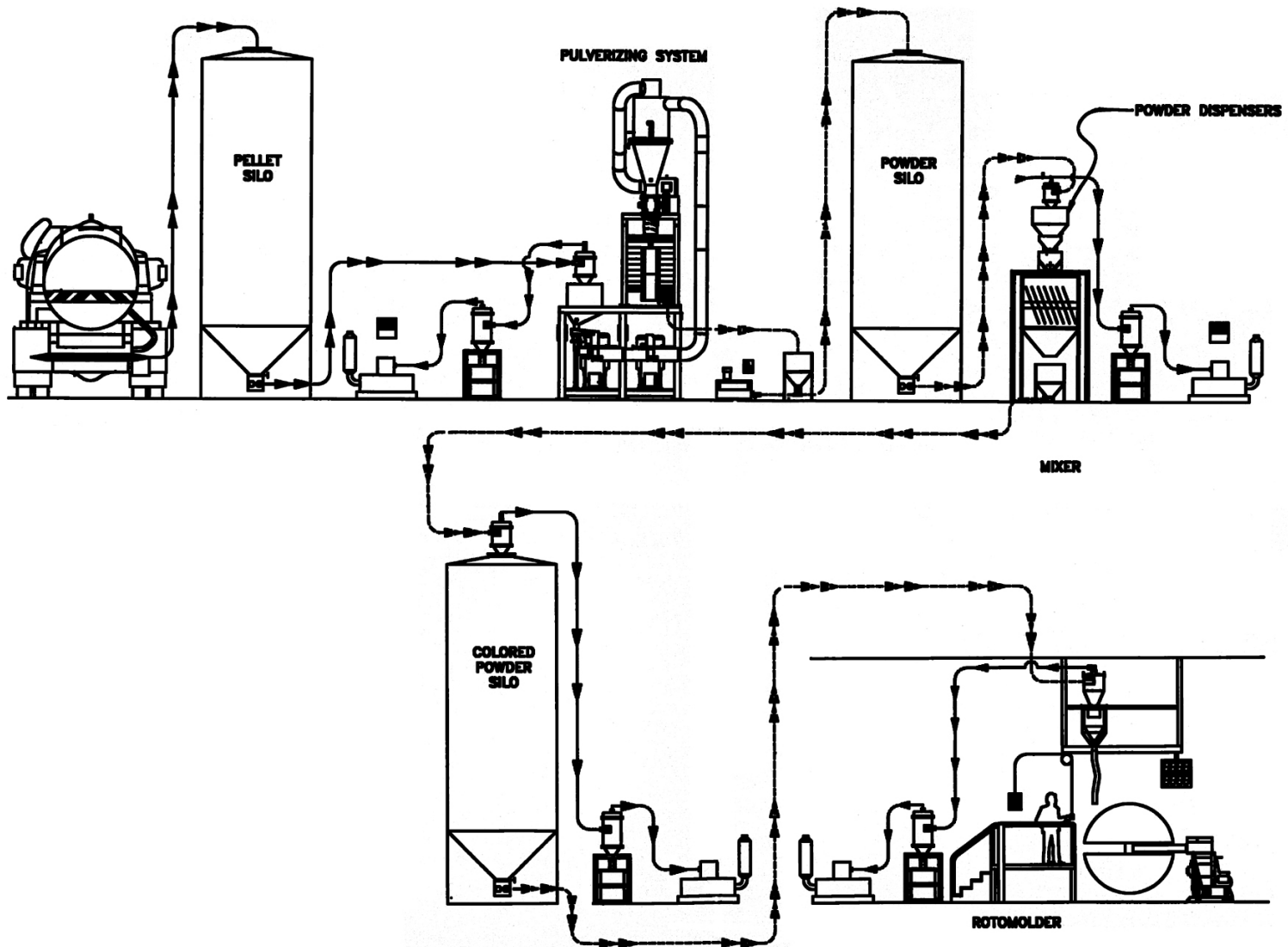

# *Railcar Delivery*



# *Railcar Connection Station*



# *Truck Delivery System*



# *Distribution Manifold*



# *Vacuum Pumping Station*



# *Color Mixing Station*

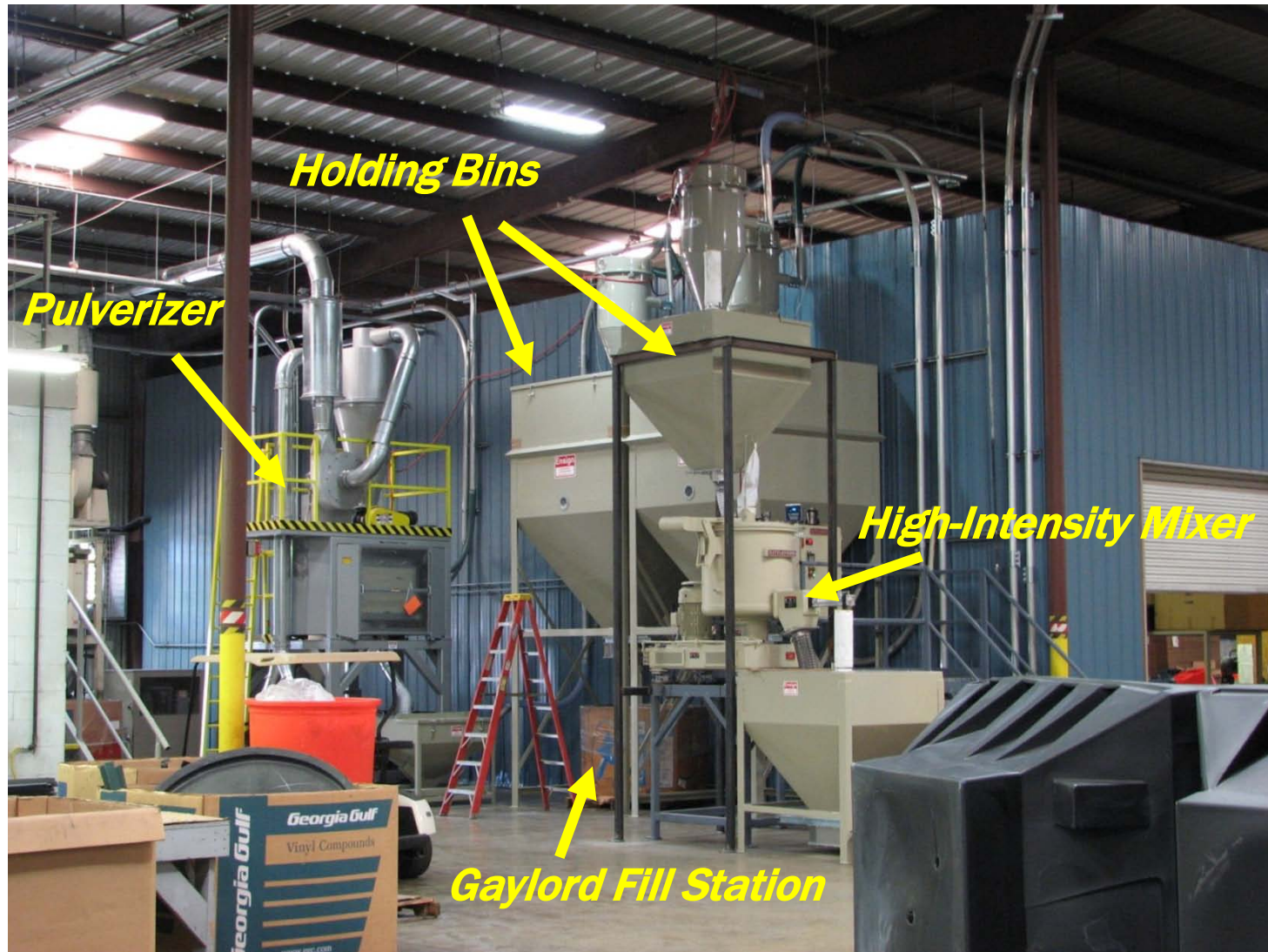

# *Distribution Center*

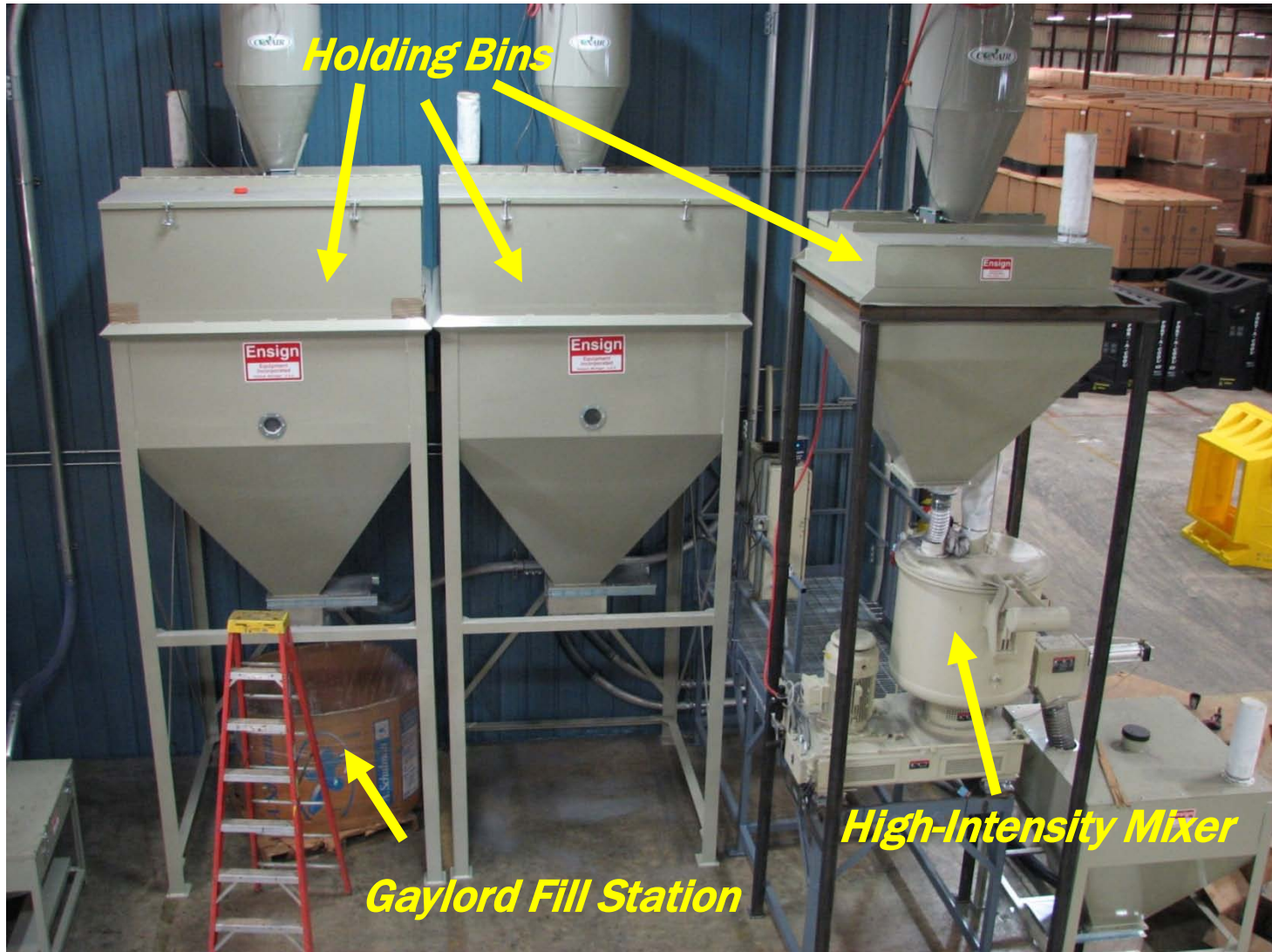

# *Holding Stations At 3 Machines*

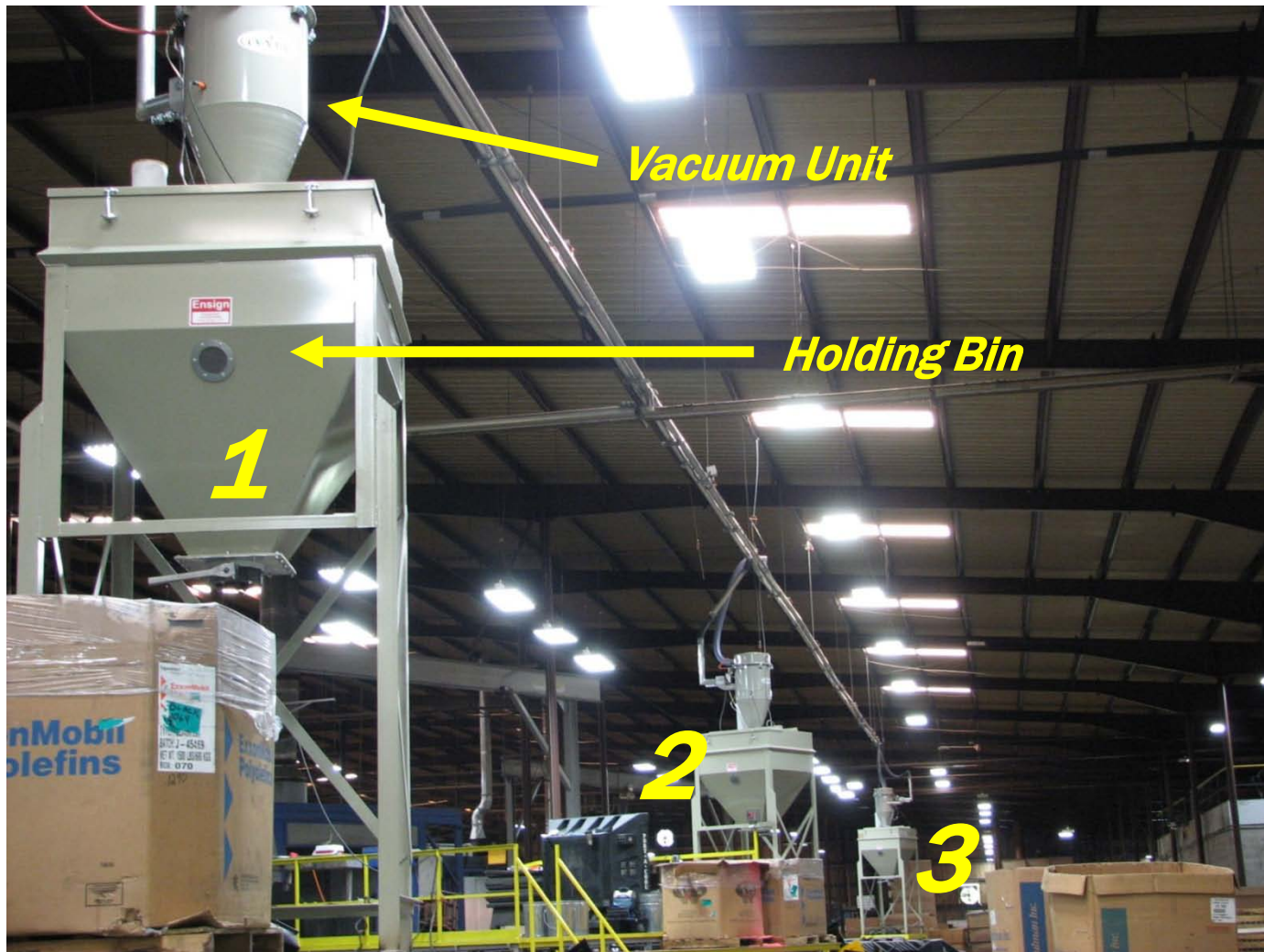

# ***Holding Stations At Machine***



***Vacuum Unit***

***Holding Bin***

# Material Weighing



# GraviMold™ Dispensing System

***Semi-automatic system  
for dispensing powder  
directly into the mold***

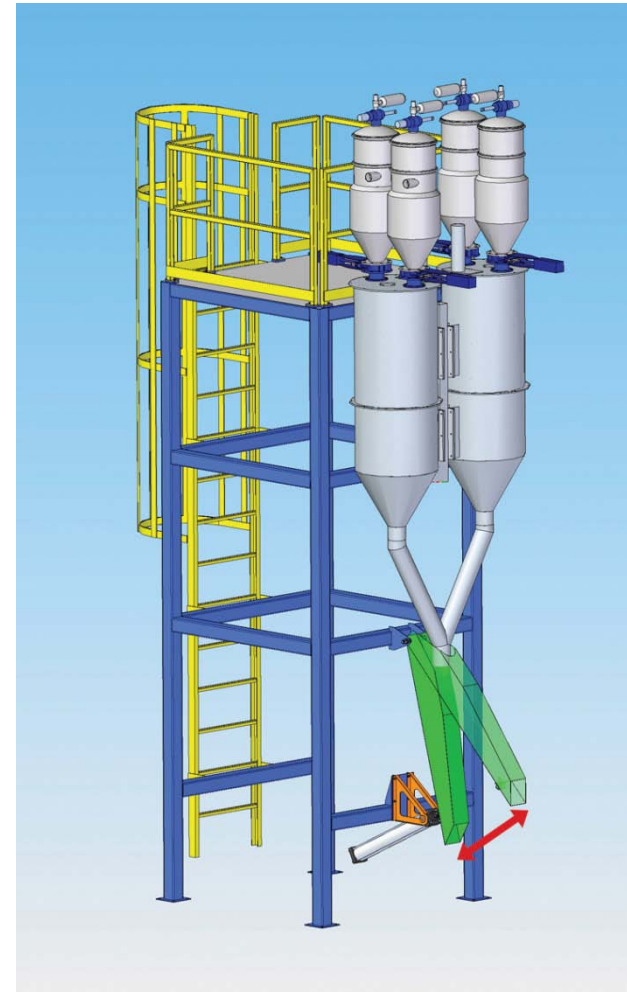

# GraviMold System Schematic

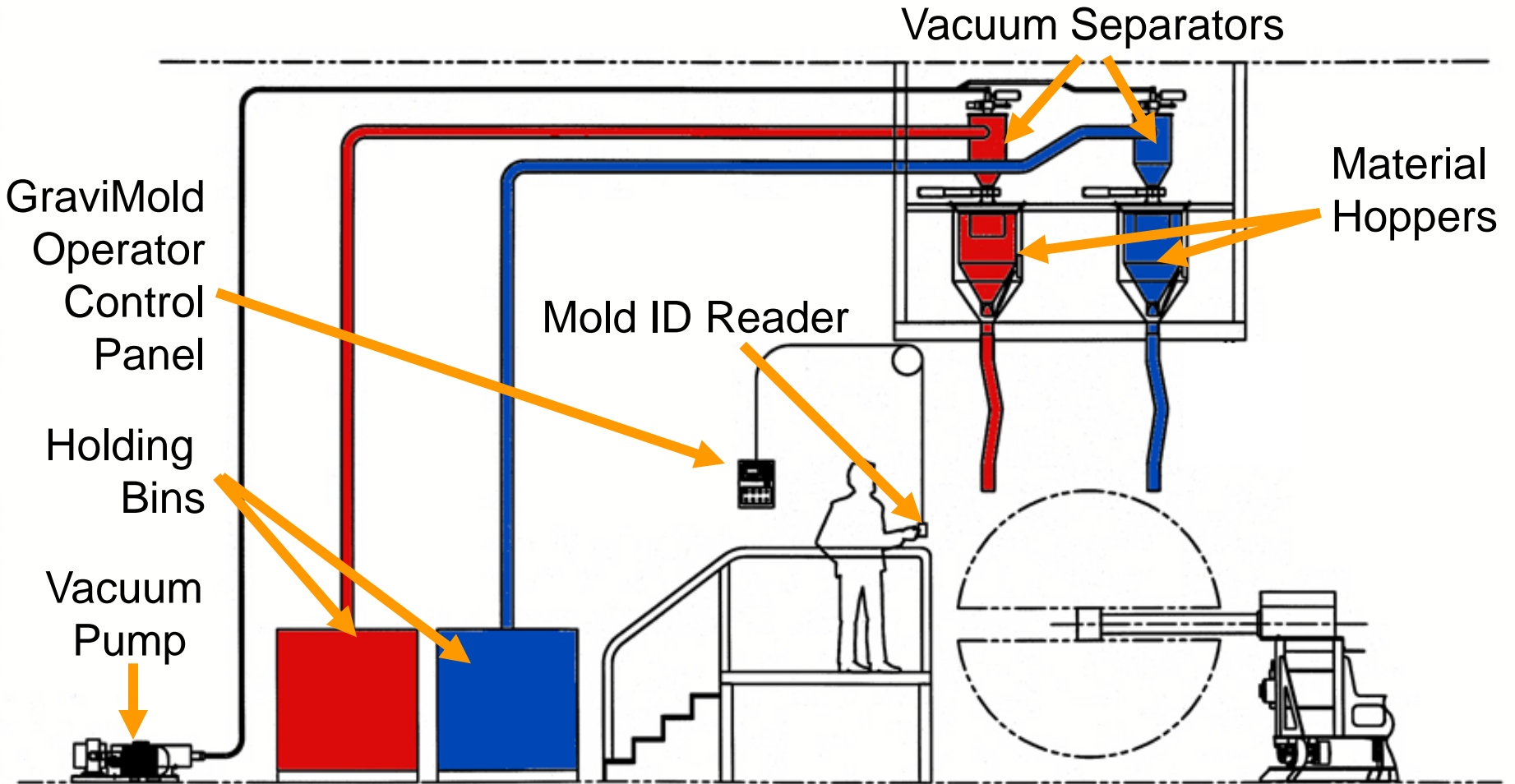

# *GraviMold Operation*

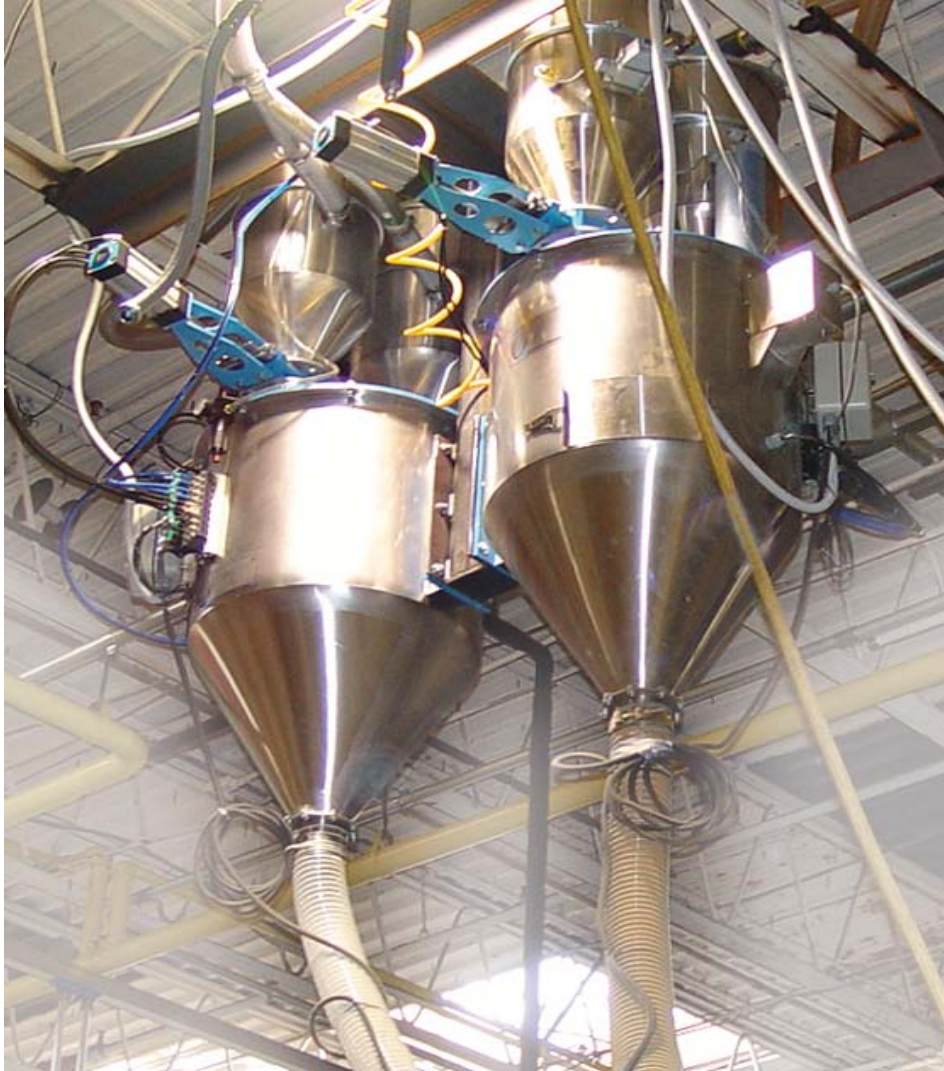

- **Automatically Identify Molds at Load Station**
- **Automatically Convey Material from Holding Bins to Weigh Hoppers**
- **Accurately Dispense Material Directly Into Mold by Loss-in-Weight Method**

# *GraviMold Installation*

**GraviMold Dispenser**

**Dispensing Hoses**

**Control Panel**



# ***Powder Dispensing Benefits***



- **Accurate Weights**
- **Minimize Spillage**
- **Reduces Contamination**
- **Reduce Manpower**
- **Increase Speed of Dosing**
- **Reduce Over-cures /Under-cures  
Due To Human Error**

# *System Details*

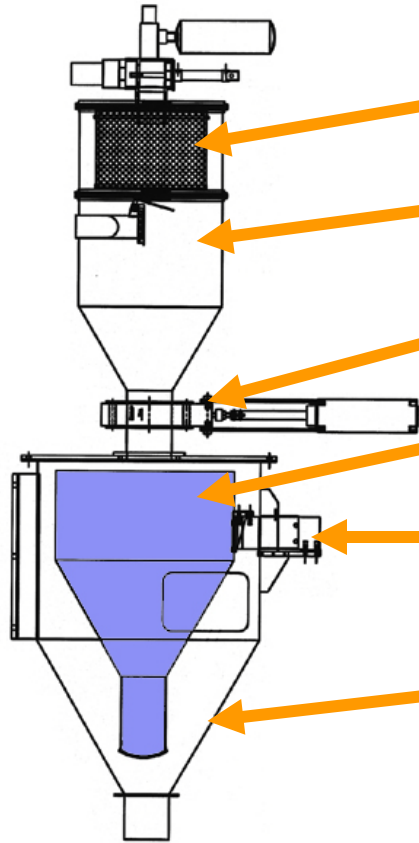

- **Dust Filter**
- **Vacuum Separator**
- **Shut-off Valve**
- **Weighing Hopper**
- **Load Cell**
- **Protection Housing**

# *Dispensing*

- **Dispensing Accuracy +/- 0.02 lbs**
- **Up to 2 lbs./sec Flow Rate**
- **Multi-color System up to 4 Colors**



## **Metering:**

- **Multi-positioning/w  
2x Air Cylinders**
- **Three Flow Rates**

# Accuracy

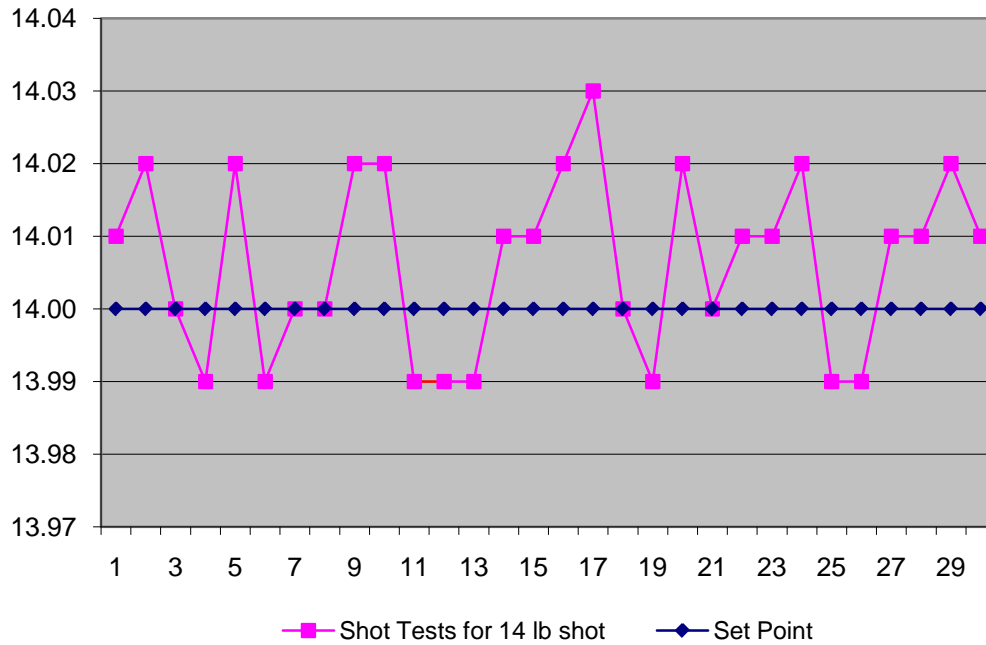

# *Mold ID Reader*



- 50 Mold Plates Per System
- Reads in any Position
- Mold ID Plug
- Plates will not foul
- 65,000 Mold Numbers can be Created
- Identify weight & hopper
- Repeats last shot until re-read
- PLC Controls

# *Automatic Mold Opening System*

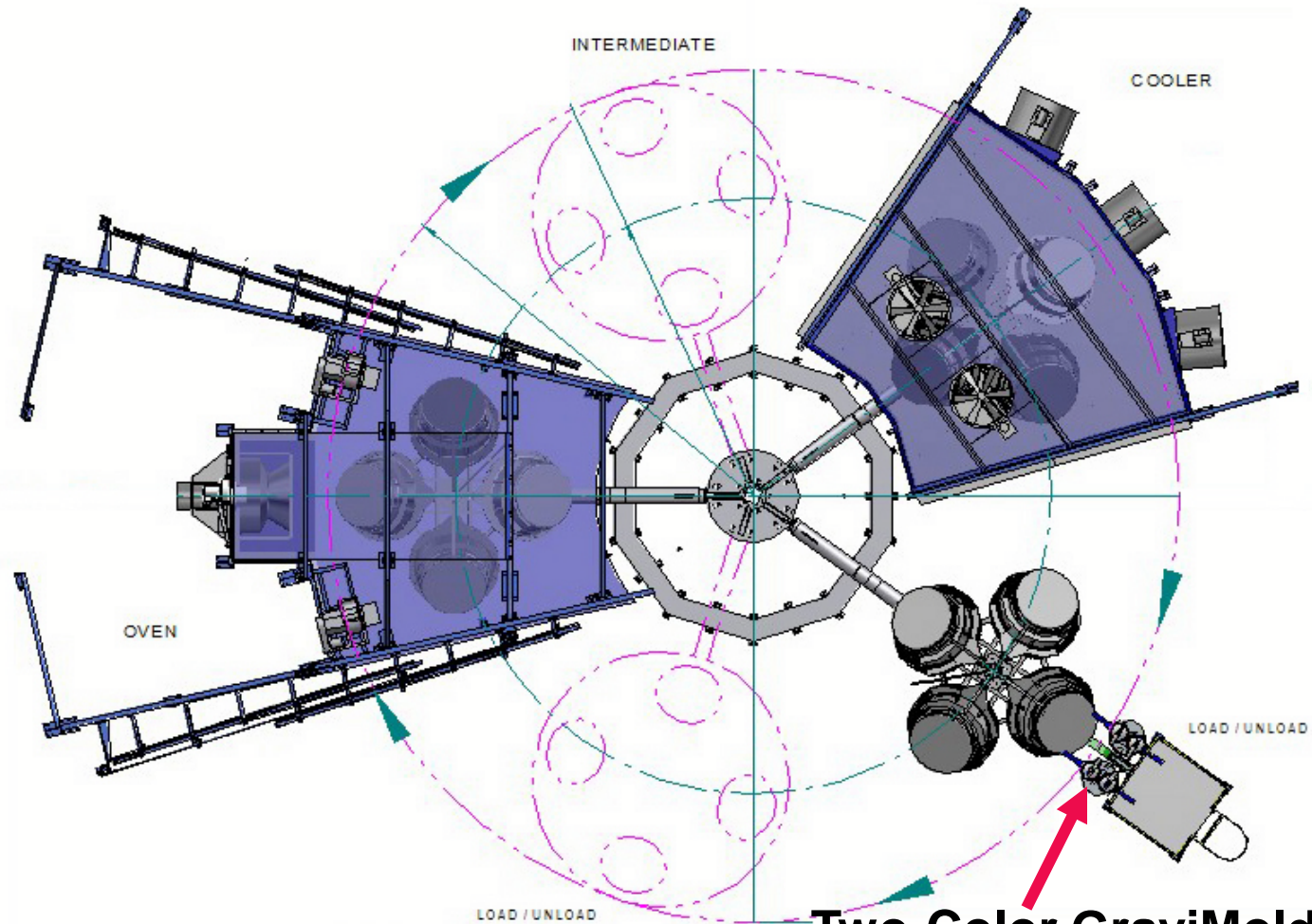

**Two-Color GraviMold  
Fill Station**

# *Dispensing Unit*

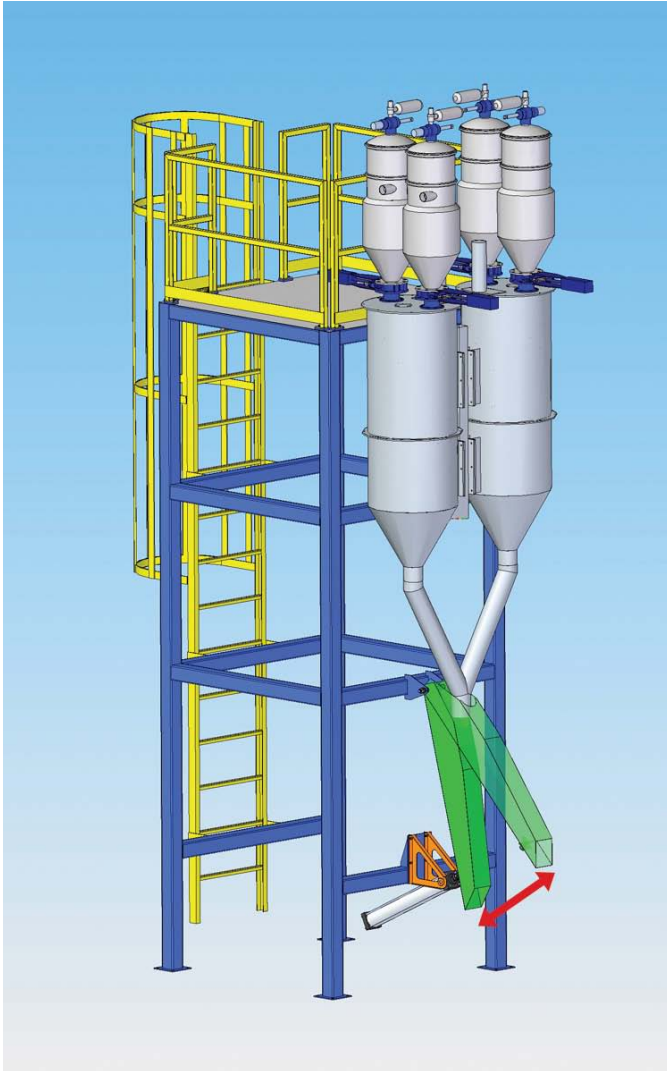

- **Two-Color Fill System**
- **Automatic Chute Positioning**

# *Auto Mold Filling*

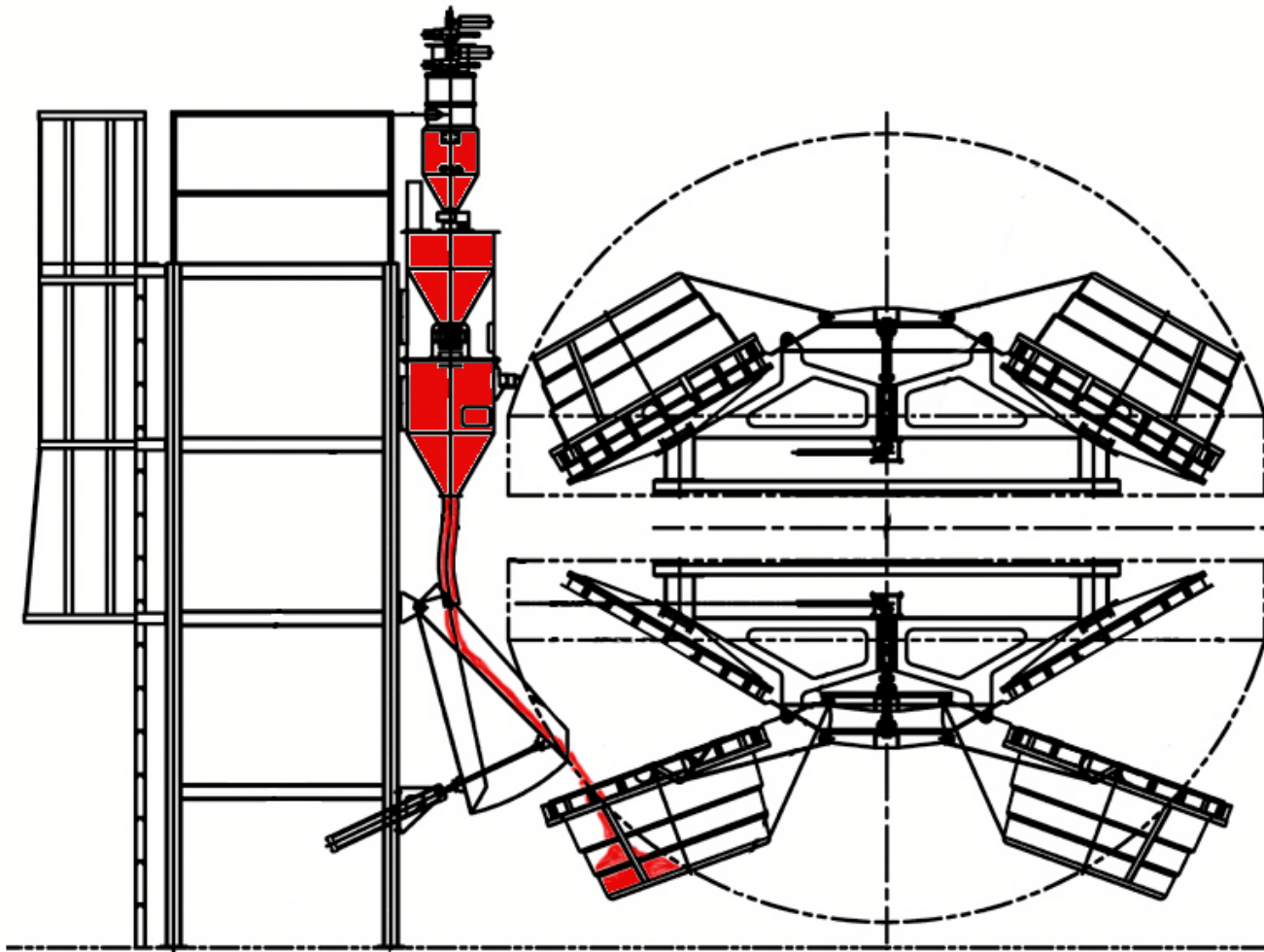

*Rotoplas 2014*

**Thank You**



**Jim Hummel**  
**Powder King**



**Harry Covington**  
**Ferry Industries, Inc.**