



*Full Automation Systems  
for electrical & conventional  
rotational molds*

***Maus***  
ROTATIONSGIESSFORMEN

**100**  
JAHRE



family-run business since 1925,  
with a production area of 5000m<sup>2</sup>



8 CNC machining centers, with a working  
space up to 6000 x 3000 x1500mm and  
5-axis



62 years of experience in manufacturing  
aluminium rotational moulding tools



plenty CAD-Workingstations and professio-  
nally trained CAD/CAM Employees



37 years of in-house aluminium foundry  
casting capacity of 1350kg



over 60 exporting countries



**Maus GmbH Modell- und Formenbau**

Am Viehweg 9, D-76229 Karlsruhe

Tel.: +49 (0) 72194874-0

E-mail: [info@maus-gmbh.de](mailto:info@maus-gmbh.de)



visit our homepage

[www.maus-gmbh.de](http://www.maus-gmbh.de)



## Range of Services

Design \* Construction \* Patternmaking  
Digitizing \* Re-engineering \* FEA \* Mock-ups  
Prototype Molds \* Prototype Parts

**All types of Rotational Molds**  
**CNC & Cast & Sheet Metal & Hybrids**  
**conventional / electrical heated**

Permanent Coatings \* Mold Accessories  
Automation \* Performance Solutions  
Modifications \* Repairs \* Refurbishments



# Large Fast Cast mold

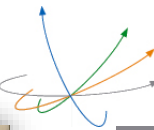



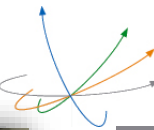

# Large CNC machined mold (21ft)





# Inserts and threads

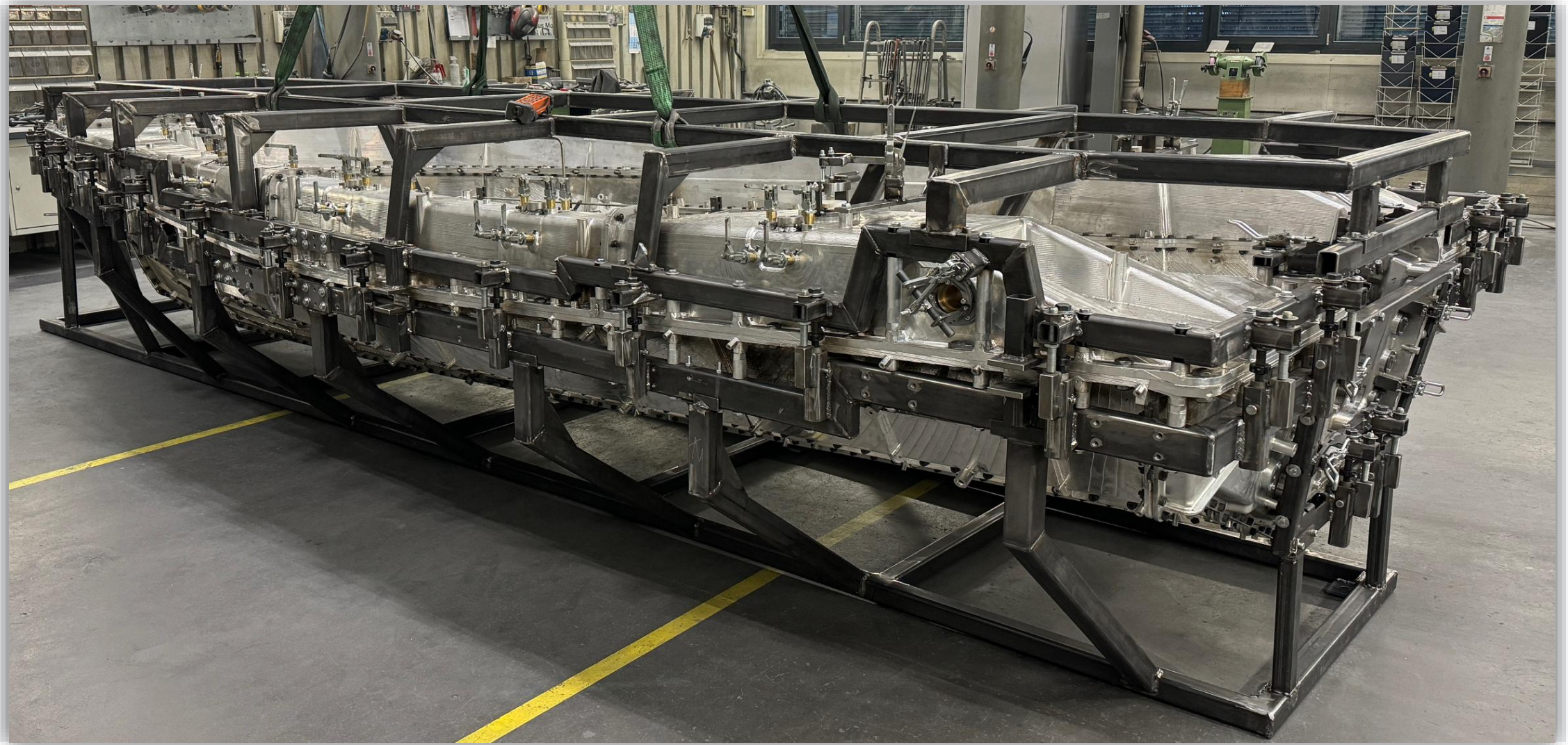
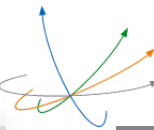



# Fully loaded with Inserts, magnets, venturiris, ejectors, etc

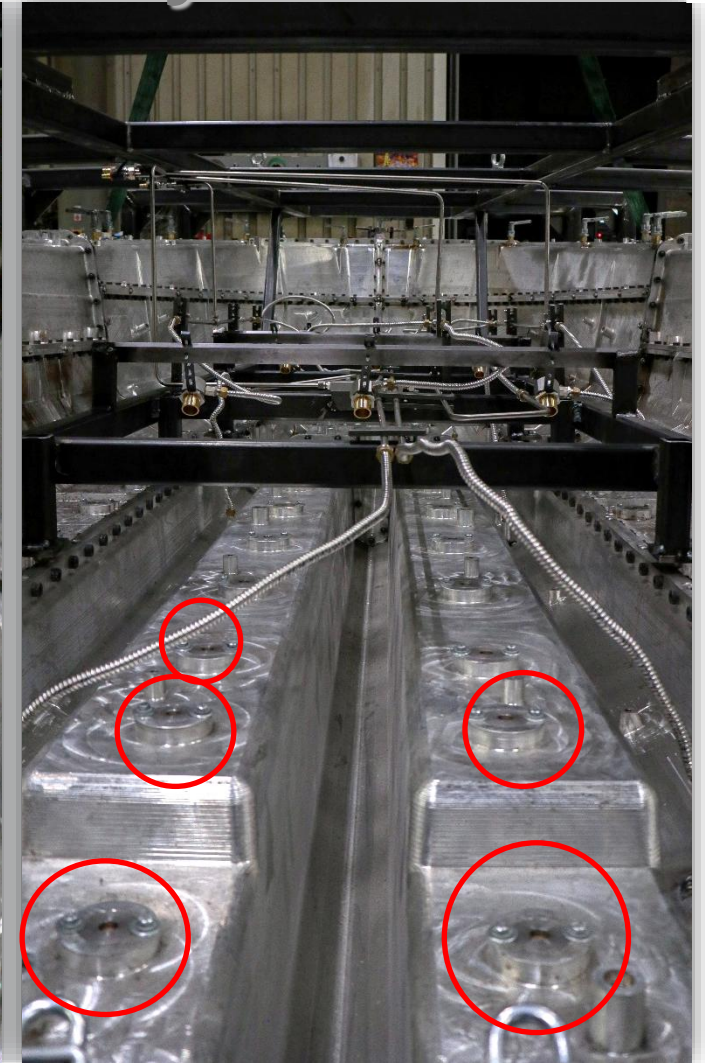
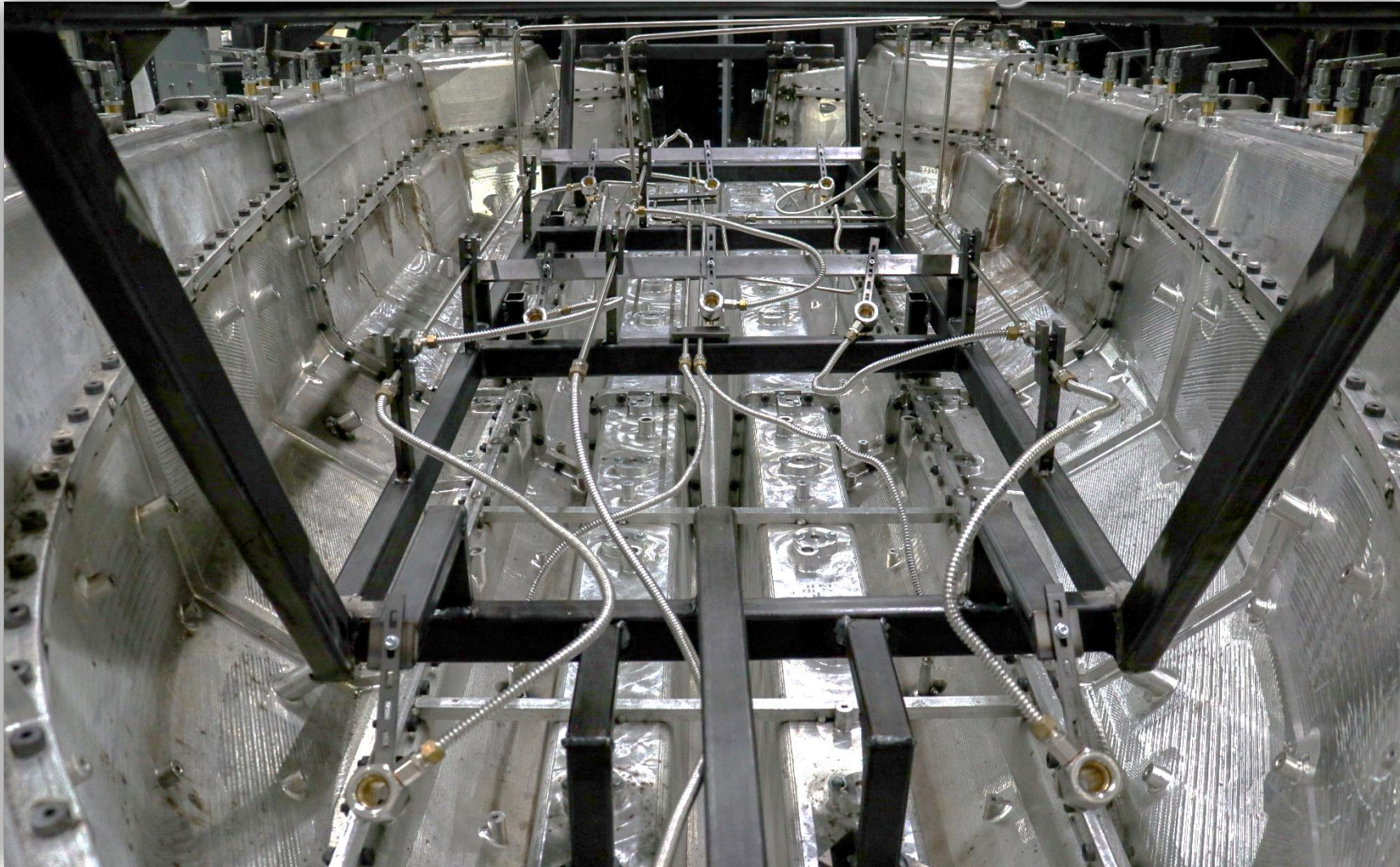
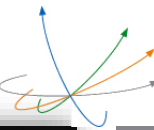

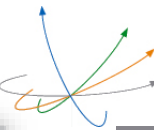

# Leonardo mold with full automation



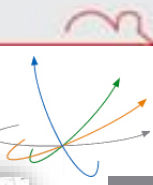

# Digital created and CNC machined wood structures

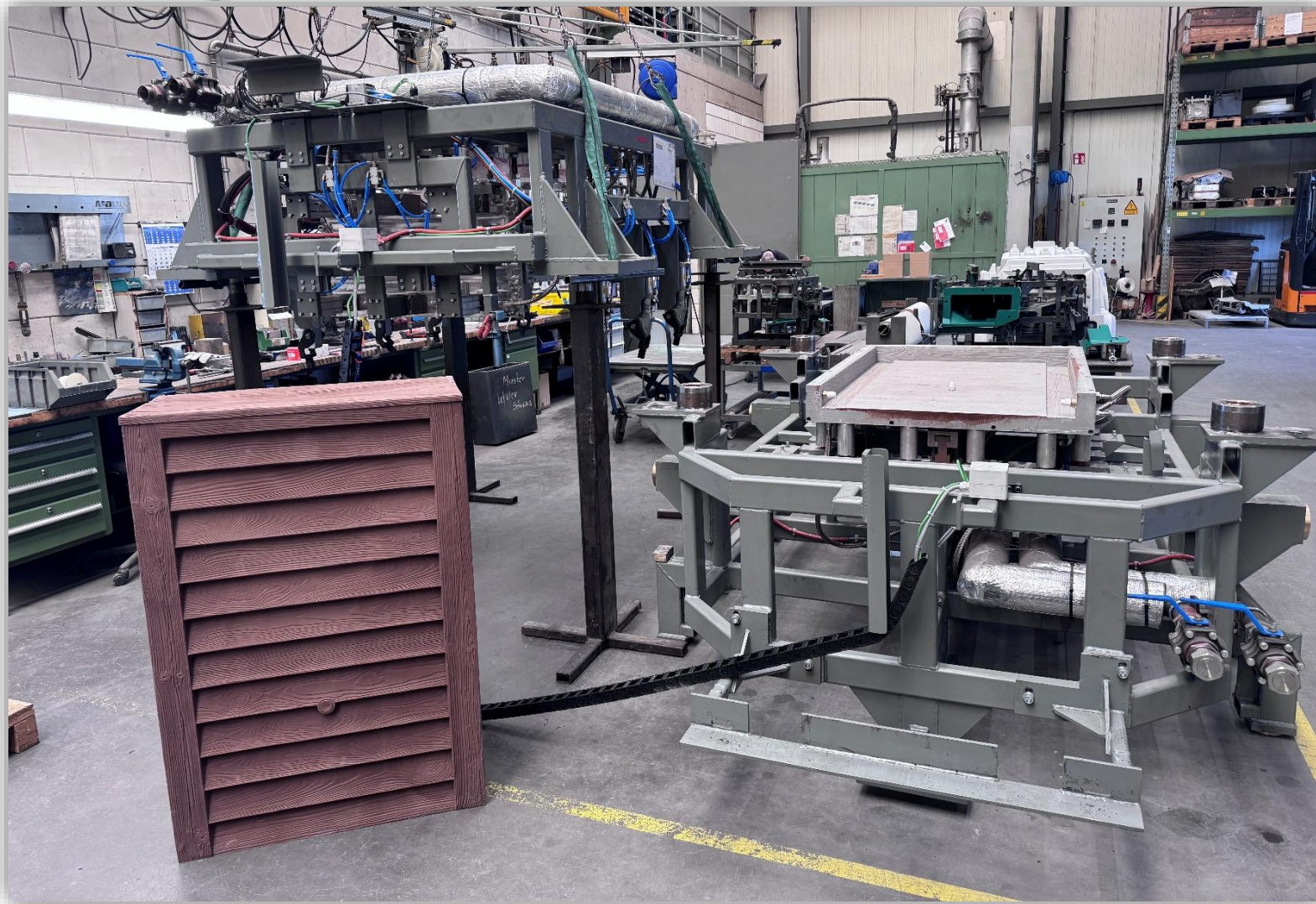



*Full Automation Systems  
for electrical & conventional  
rotational molds*

***Maus***  
ROTATIONSGIESSFORMEN

**100**  
JAHRE



# Automatic mould filling

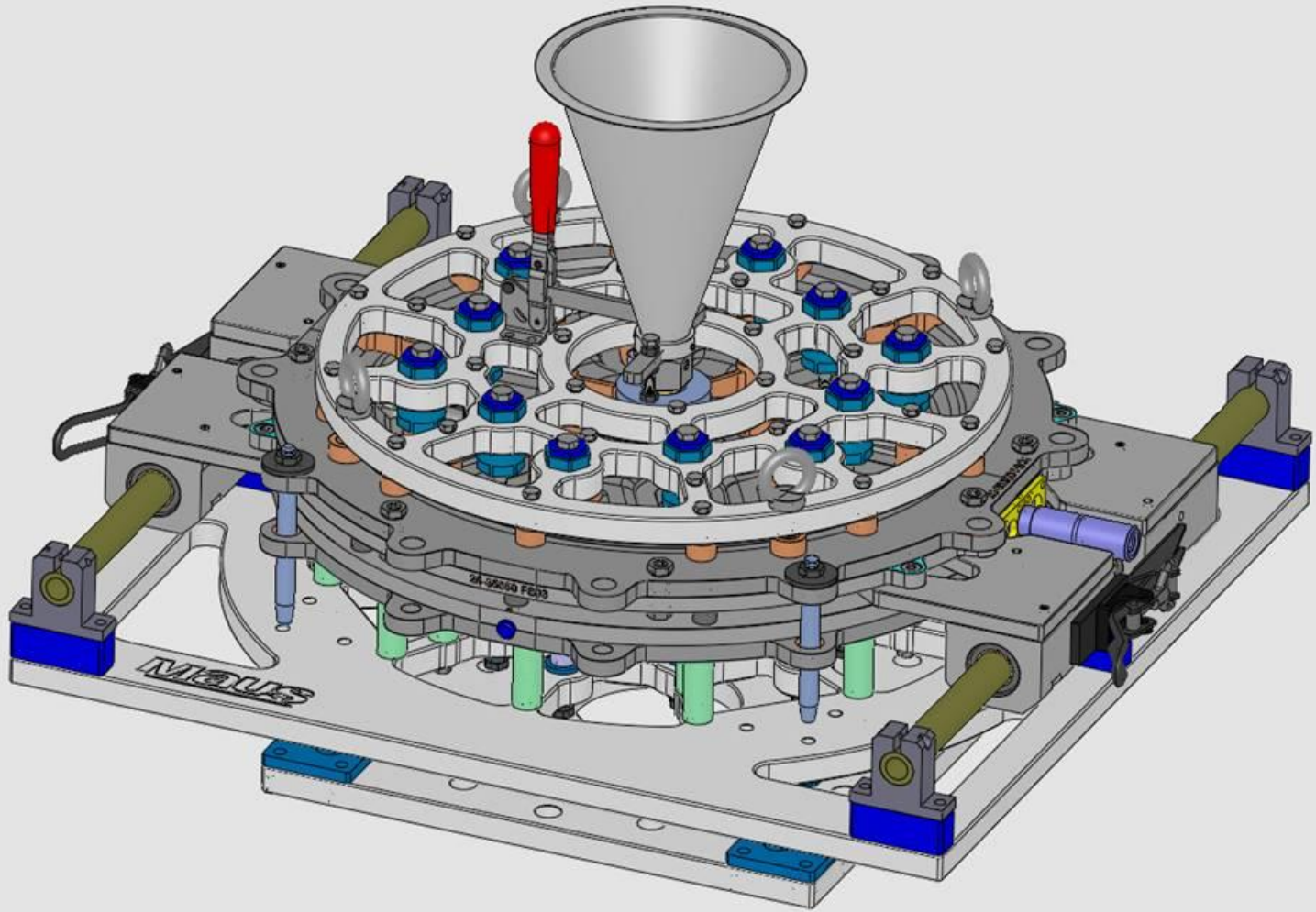



# Automatic mould filling

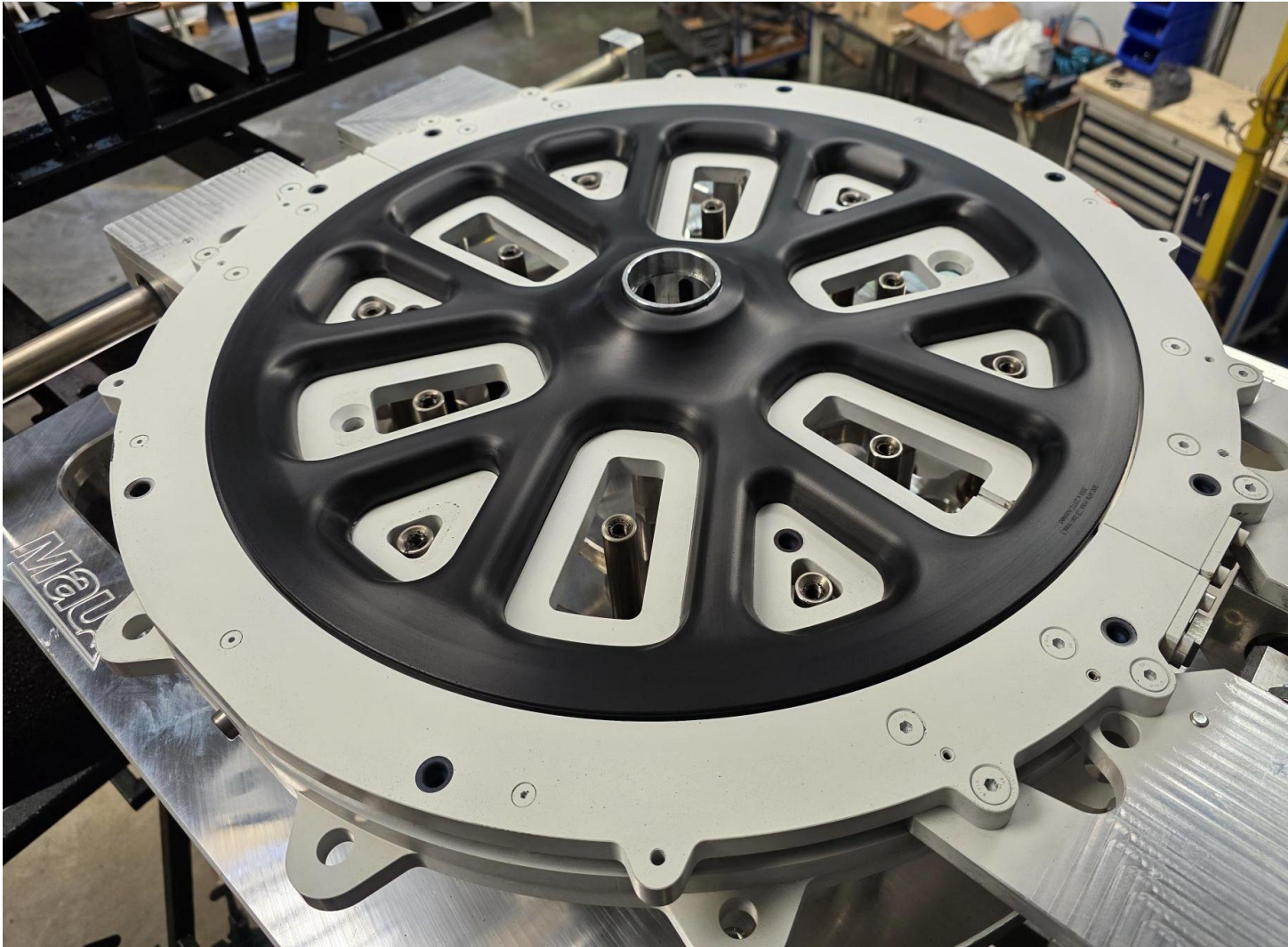

- ✓ funnel placed on closed mold
- ✓ Utilizing venturi & vacuum system
- ✓ 98% fill volume
- ✓ 40sec "full-fill"





# MAUS Drop-Boxes



- ✓ minimized thermal bridging to inside of drop box
- ✓ BMC-Green coated to enable easy and low friction travel of material + release properties
- ✓ suitable for **24/7** production



# Pneumatics for hot-air rotomoulding



- ✓ Designed for Rotomolding
- ✓ Easy & Simultaneously Action
- ✓ Powerful but gentle stroke
- ✓ Preventing mold damages
- ✓ Repeatable & easy operation
- ✓ Also in hard to reach areas
- ✓ Easy maintenance



# pneumatic mold closures

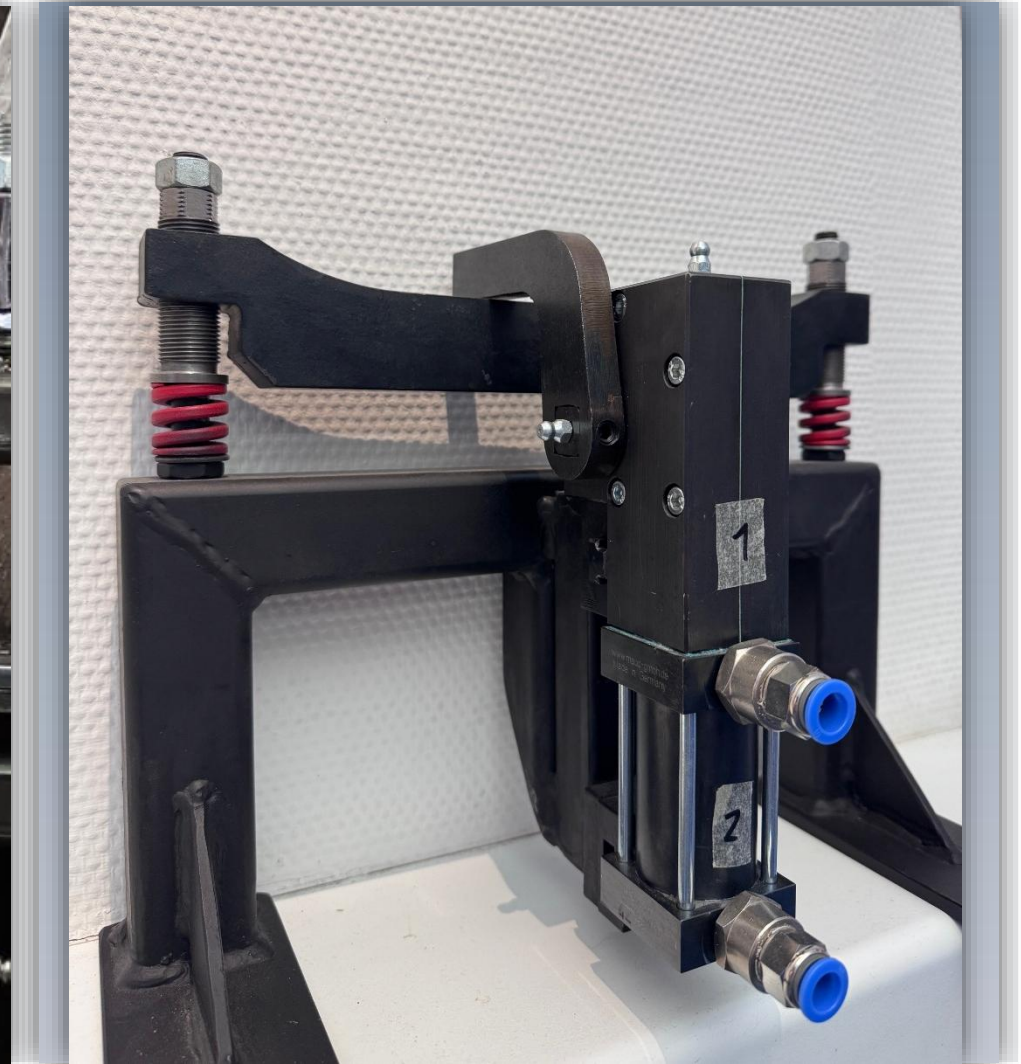
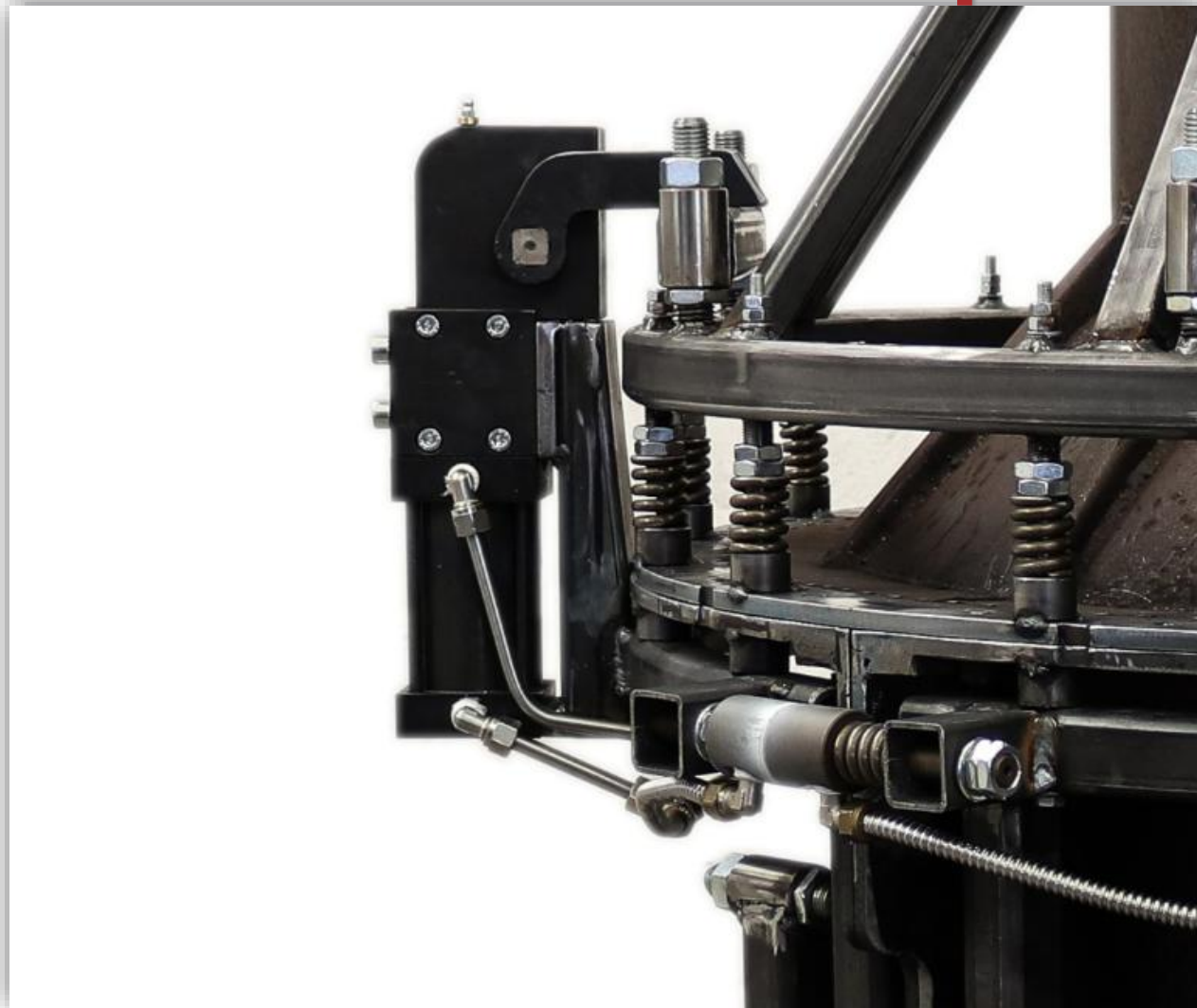



# pneumatic clamping

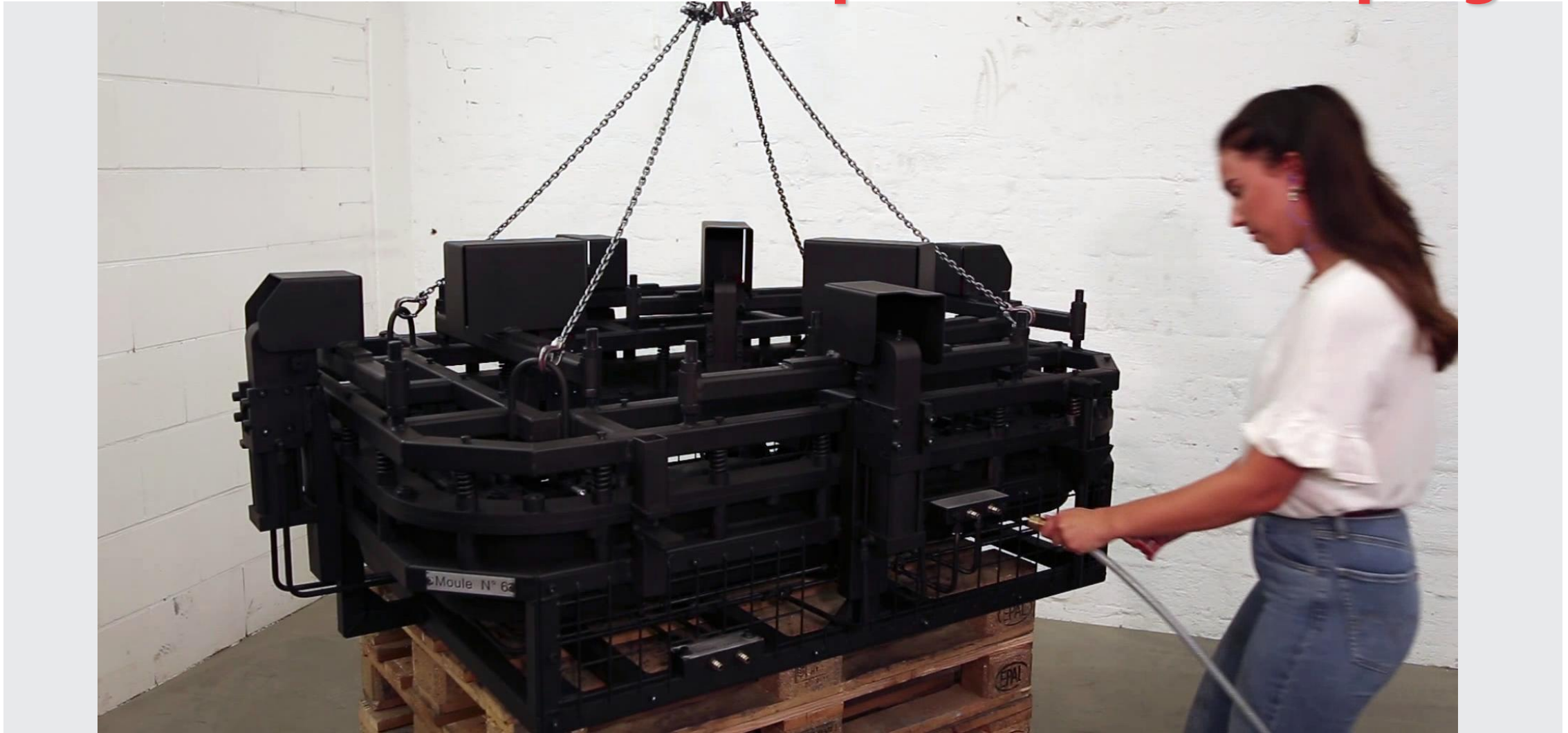



# pneumatic retractions





# Pneumatic retraction of loose parts

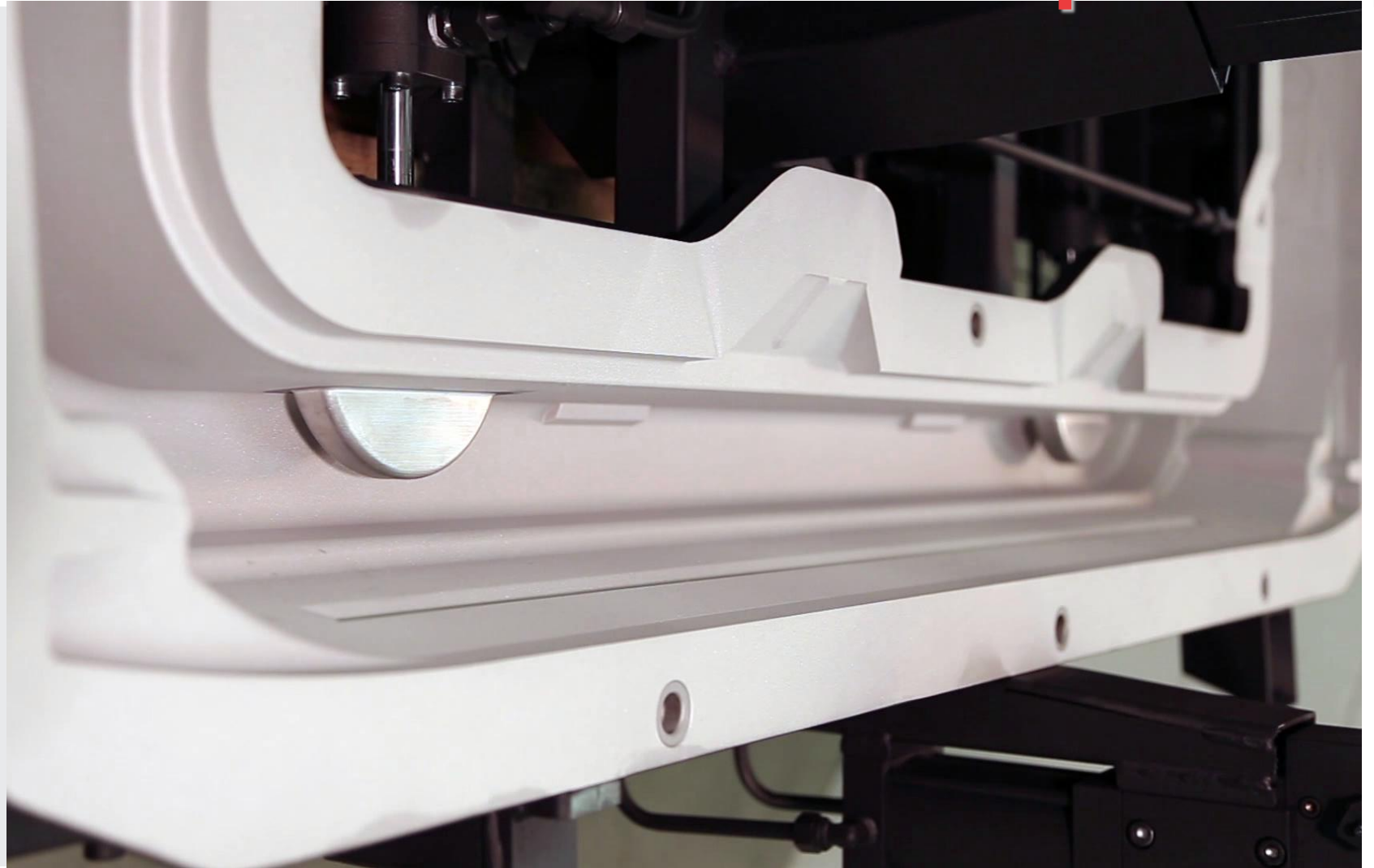



# pneumatic prying and ejection





# Pneumatics on Cast/CNC fuel tank mould

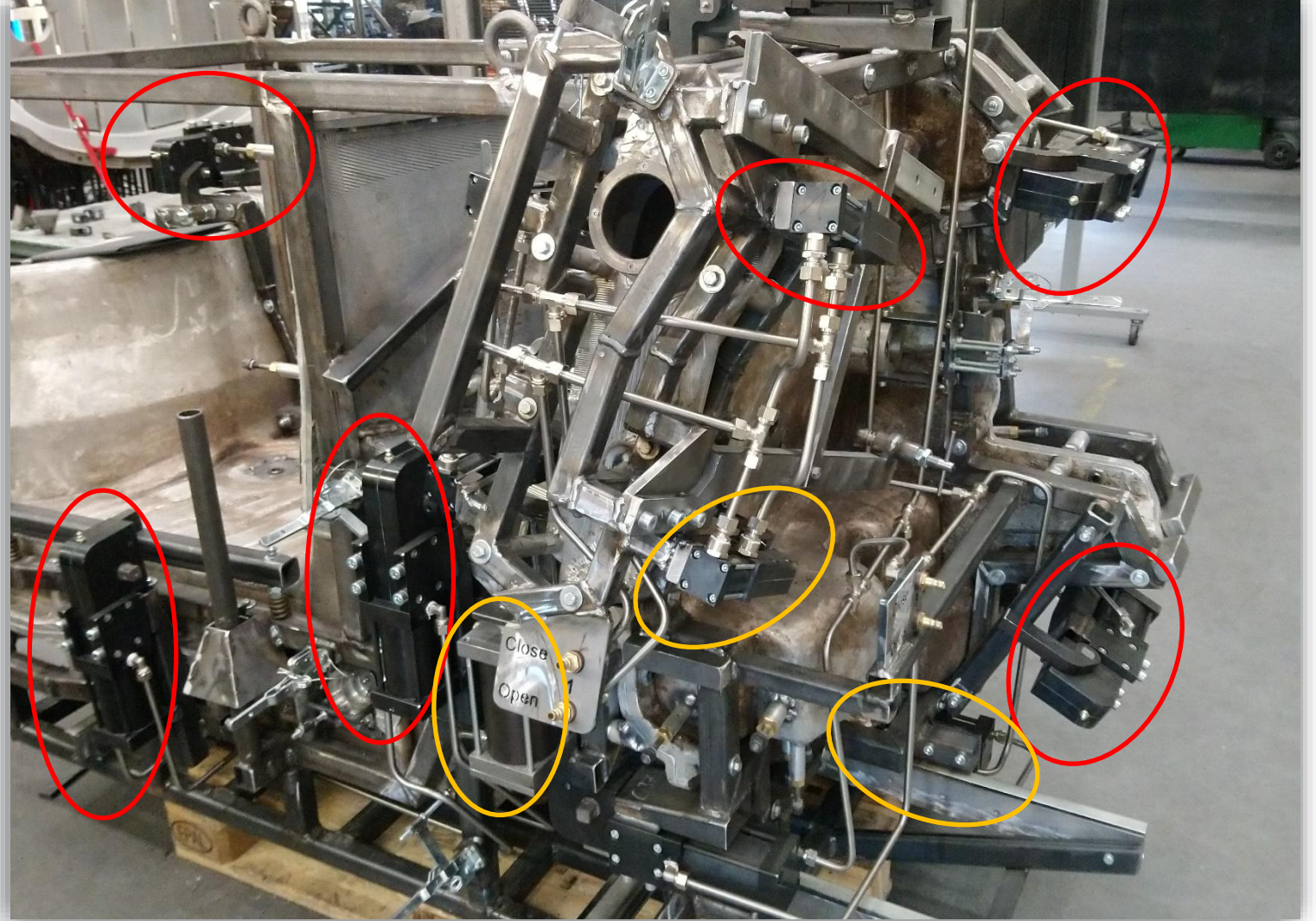
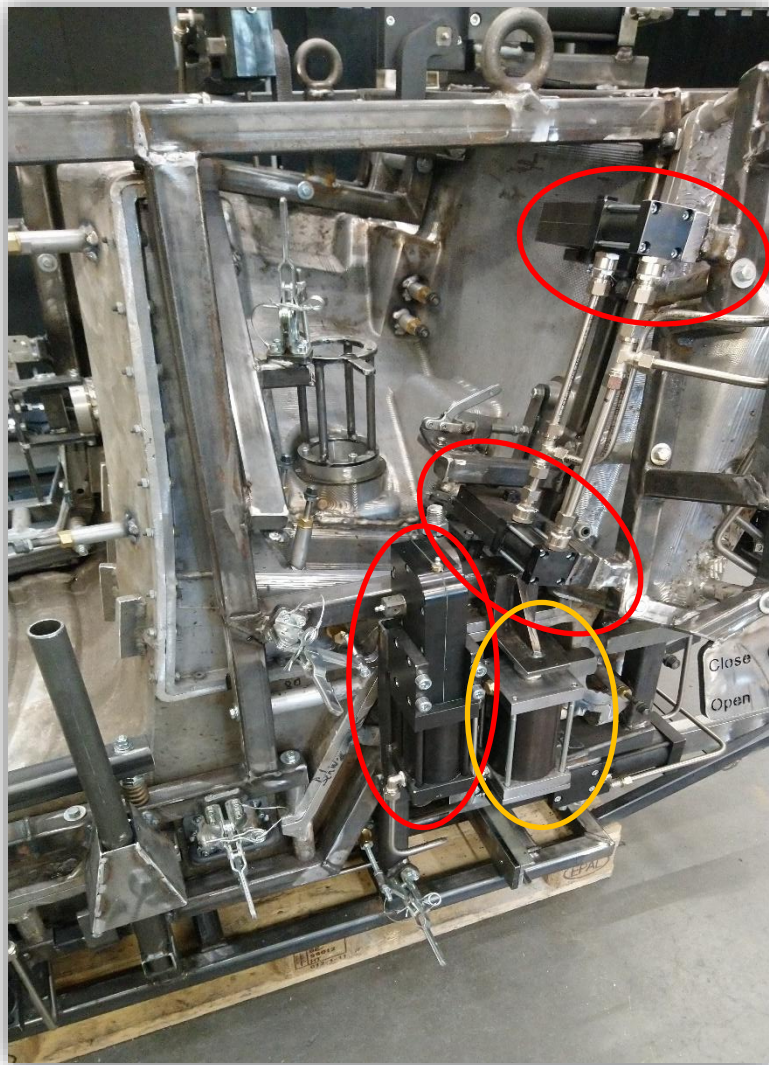

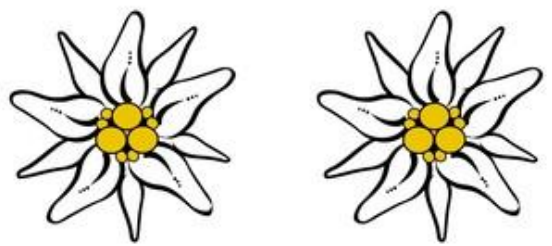
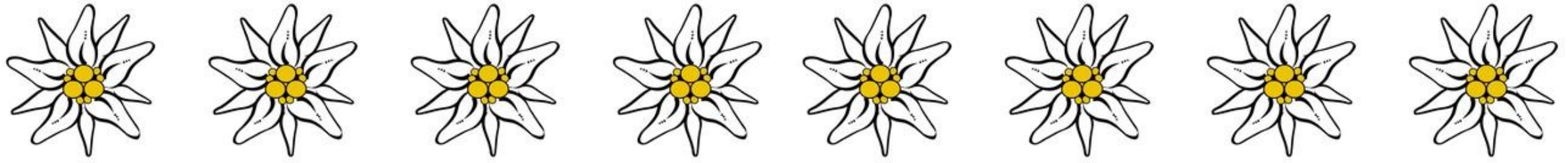

# **MAUS**

## **ROTATIONSGIESSFORMEN**

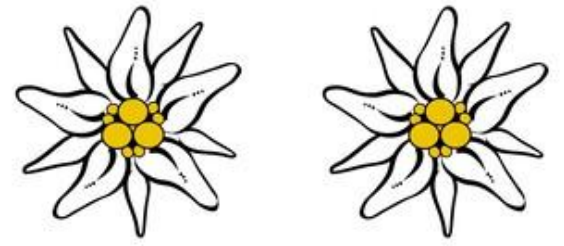
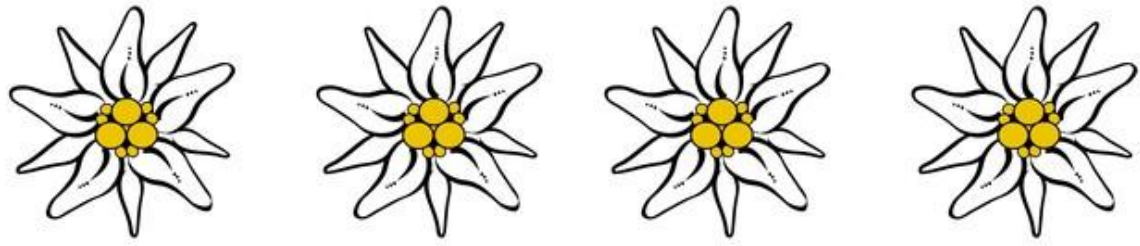
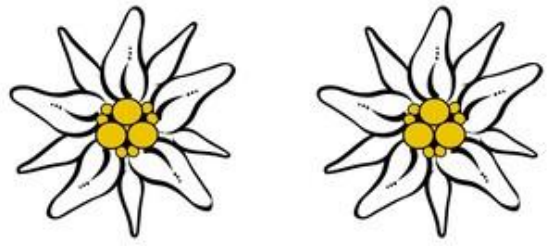
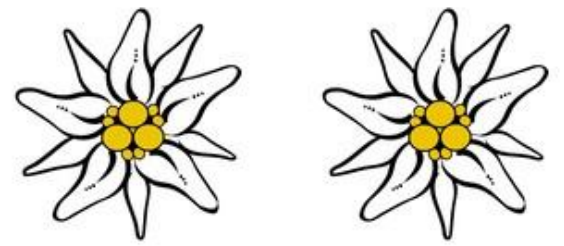
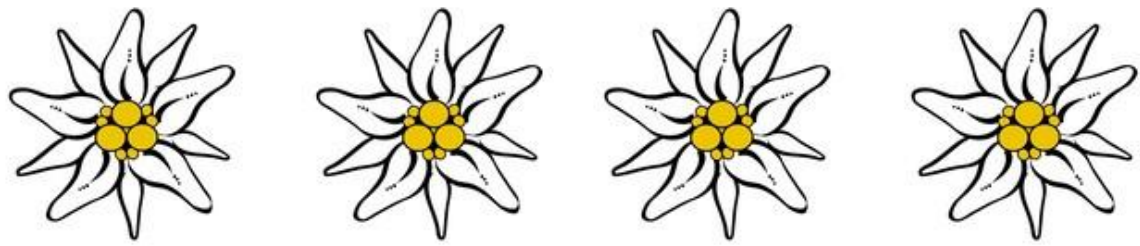
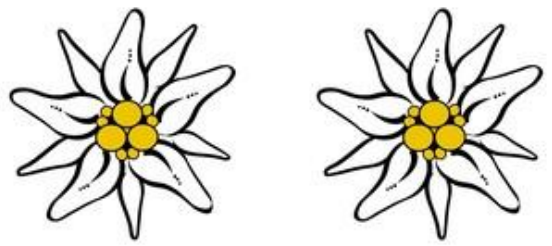
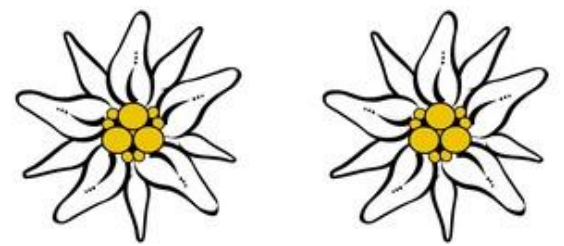



# Edelweiss Coating on Flanges



- developed especially for parting lines
- combining wearing properties with strong release
- reducing cleaning time for flanges
- cuts maintenance work and down-time

# Edelweiss Coating on Flanges

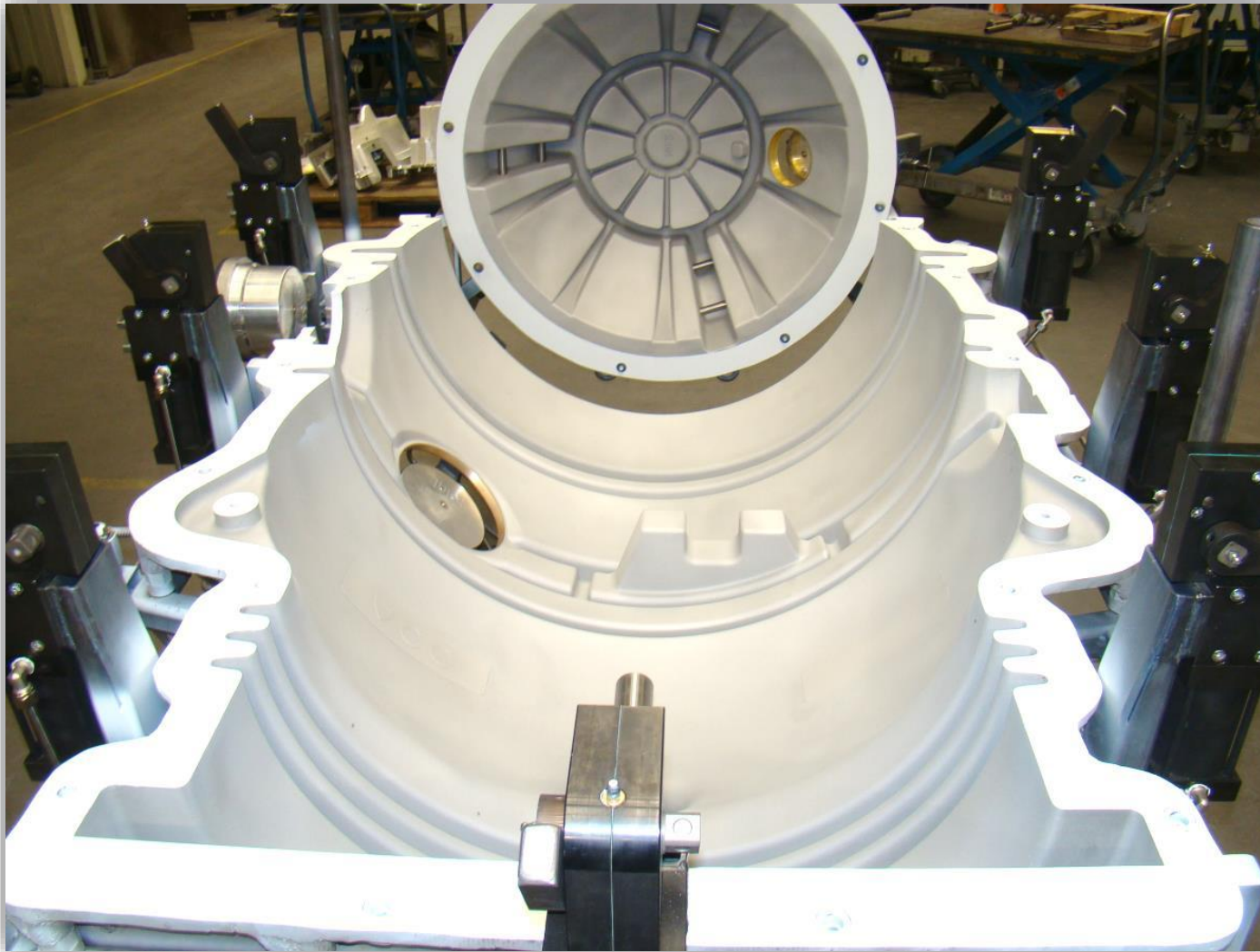

- Pure & bright white colour, grabs the attention of operators
- Contaminations are easy to spot
- Smooth & hard surface, like glass, easy to clean
- Refresher available !

# Technical features Edelweiss Coating

- Extraordinary Hardness and abrasion resistance
- After curing temperature resistant up to 700°C
- Glass-like, non stick surface
- Food proof, no fluorochemicals, **no PTFE**
- Coating can be easily removed by sandblasting
- Partial repairs are possible (blasting/painting/curing)
- Refresher to charge up release properties

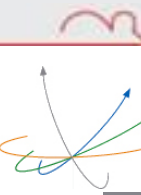

# NEW – Formula for self application - NEW

- Two components in two bottles (configured)
- Final mixing process on site
- 4 days shelf-life after mixing
- Curing process in rotomolding oven (w/o rotation)
- Flange preparation by sandblasting
- Application by spraying, rolling or brushing



*Full Automation Systems  
for **electrical** & conventional  
rotational molds*

***Maus***  
ROTATIONSGIESSFORMEN

**100**  
JAHRE



# Prototype electrical Robomoulds

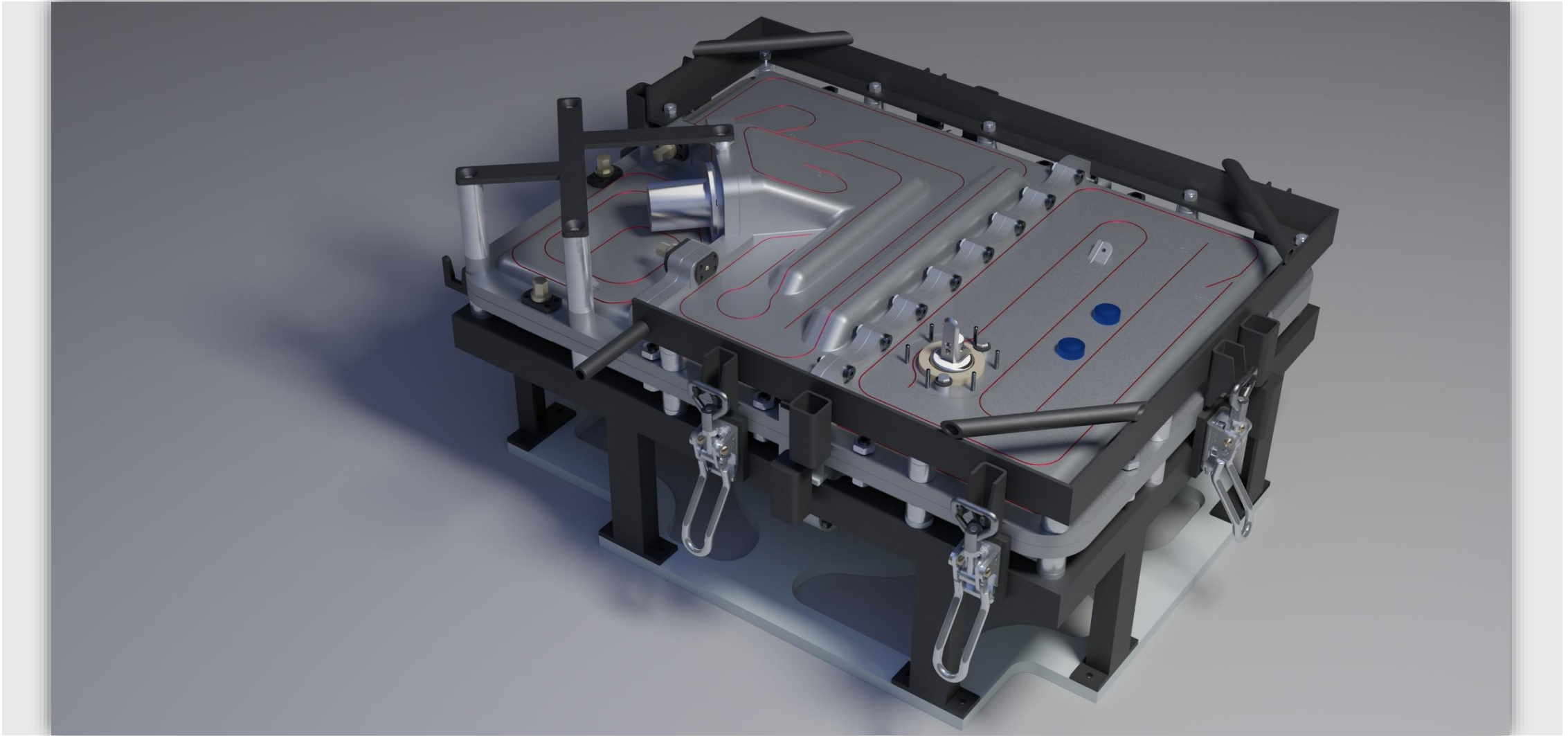



# Prototype electrical Robomoulds

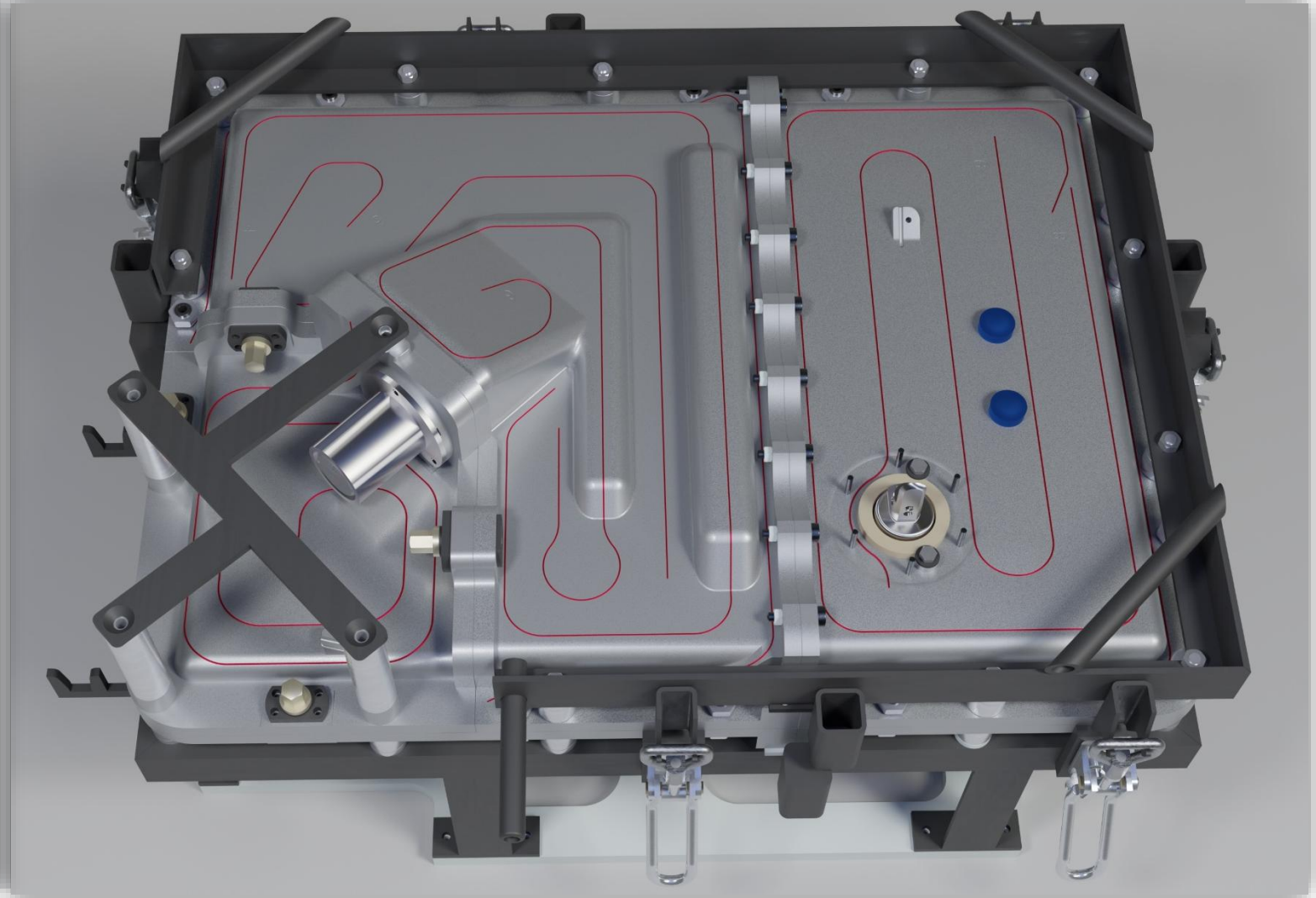
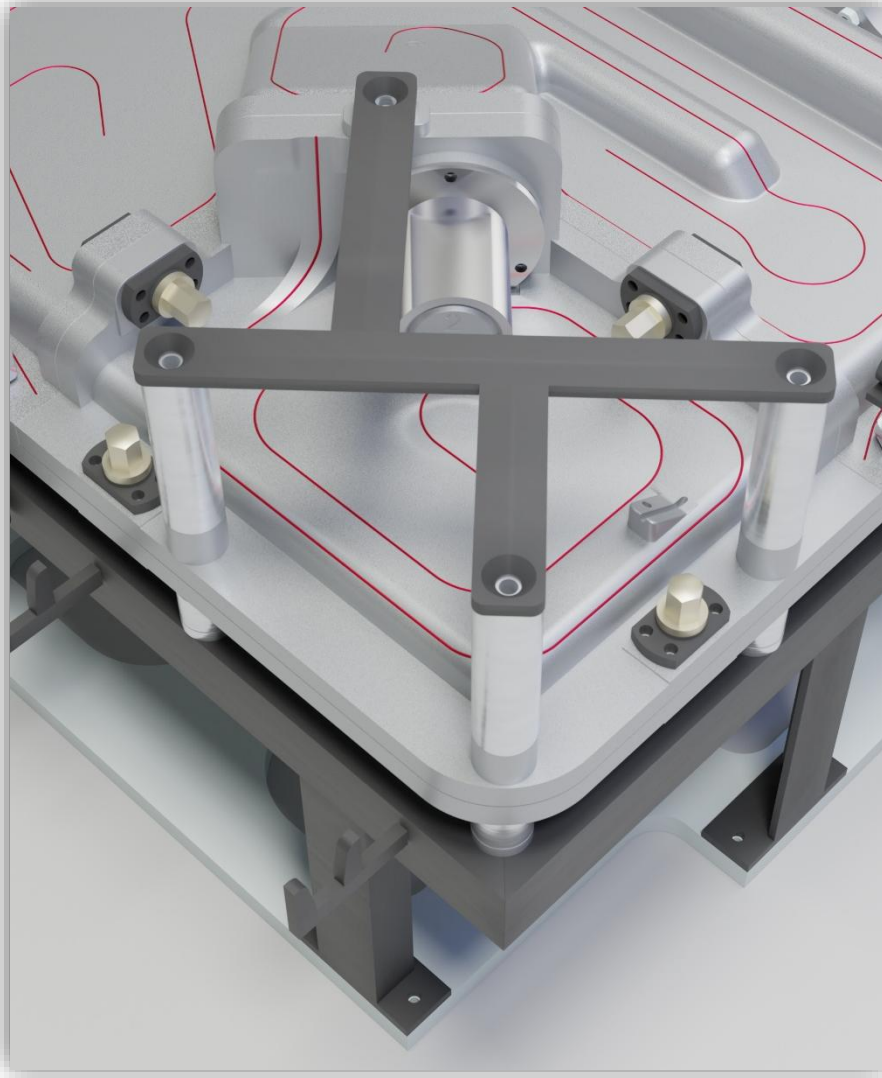



# Prototype electrical Robomoulds



# Semi manual electrical Robomoulds





# „Multibox“ for Filling, Venting, Control ...



- \* Non insulated hopper/reservoir
- \* Inside C40 coated
- \* Electrical pressure control
- \* Safety valve exits
- \* Active venting (pressurization)
- \* Built-in Thermocouple for PIAT
- \* Easy maintenance



# Prying cylinders for Robomoulds

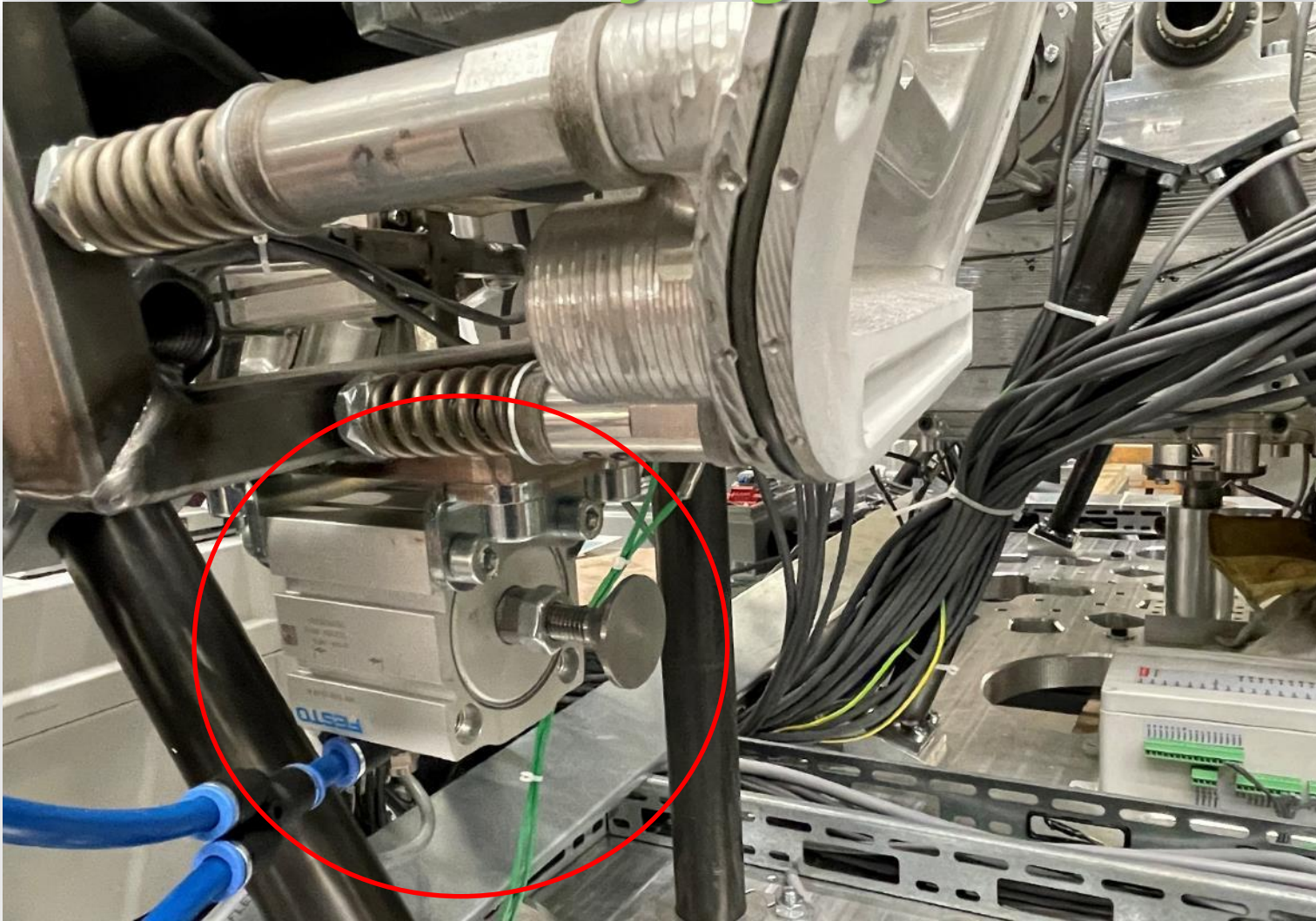

# Intelligent & automated demoulding platform

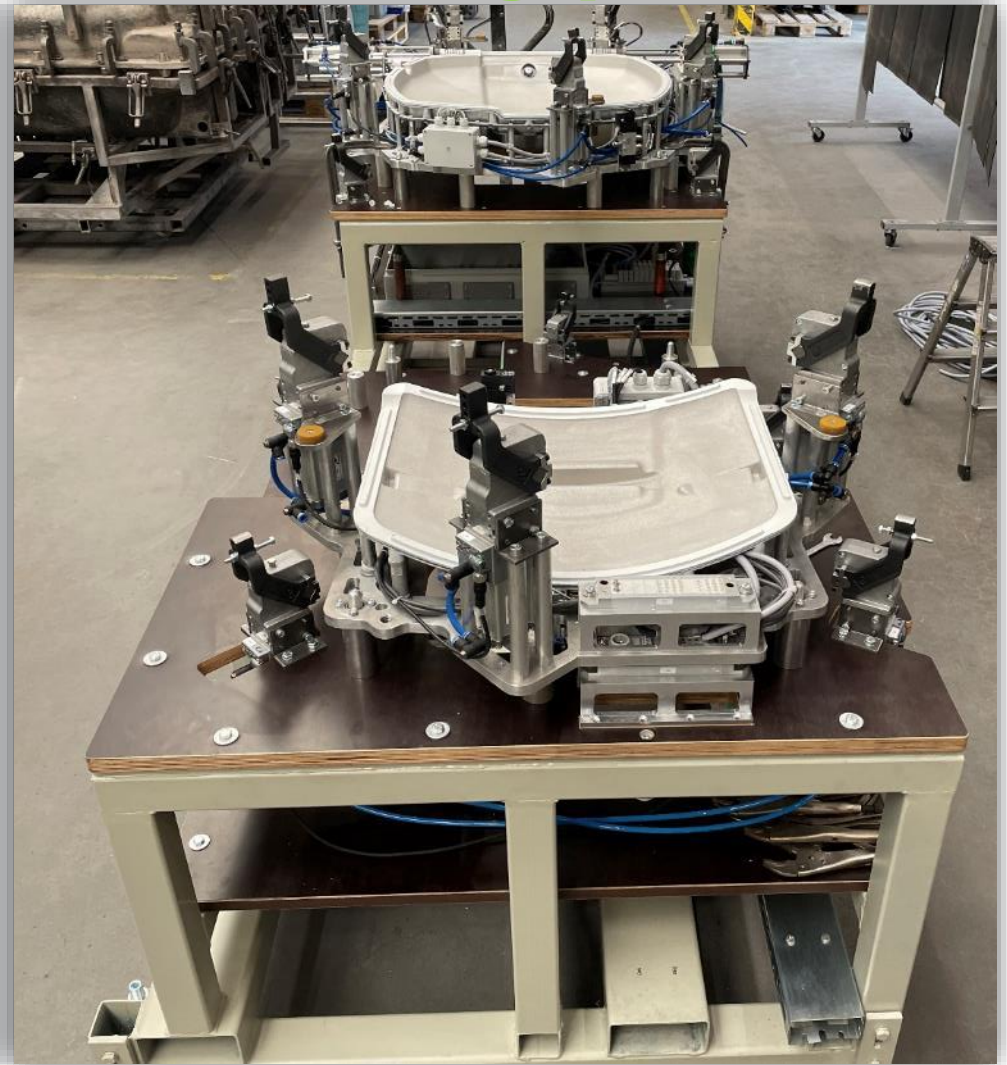

# Fully automated electrical Robomoulds



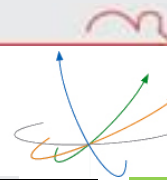

# Fully automated electrical Robomoulds

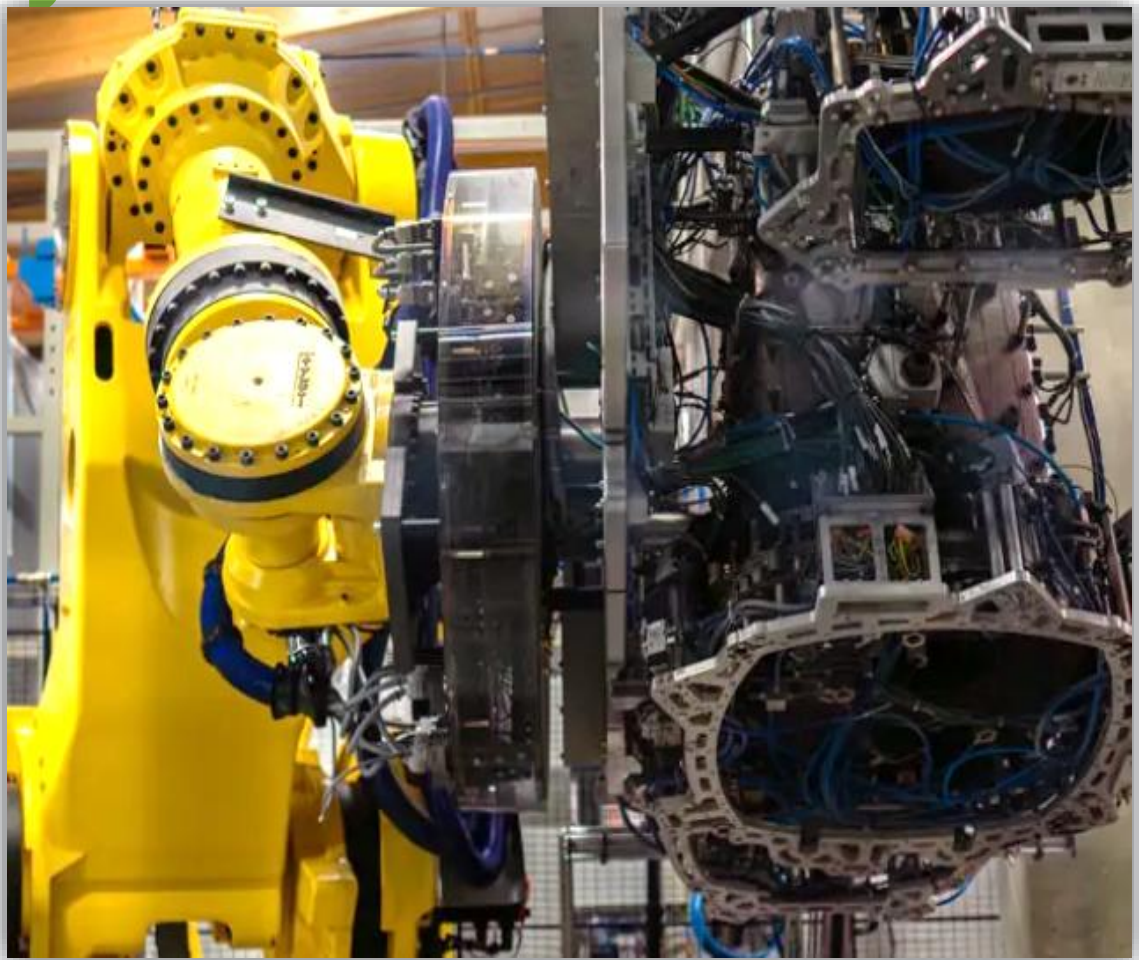

*Pics & videos courtesy of Favorit Tuote Oy*





# Automatic retraction for Robomould

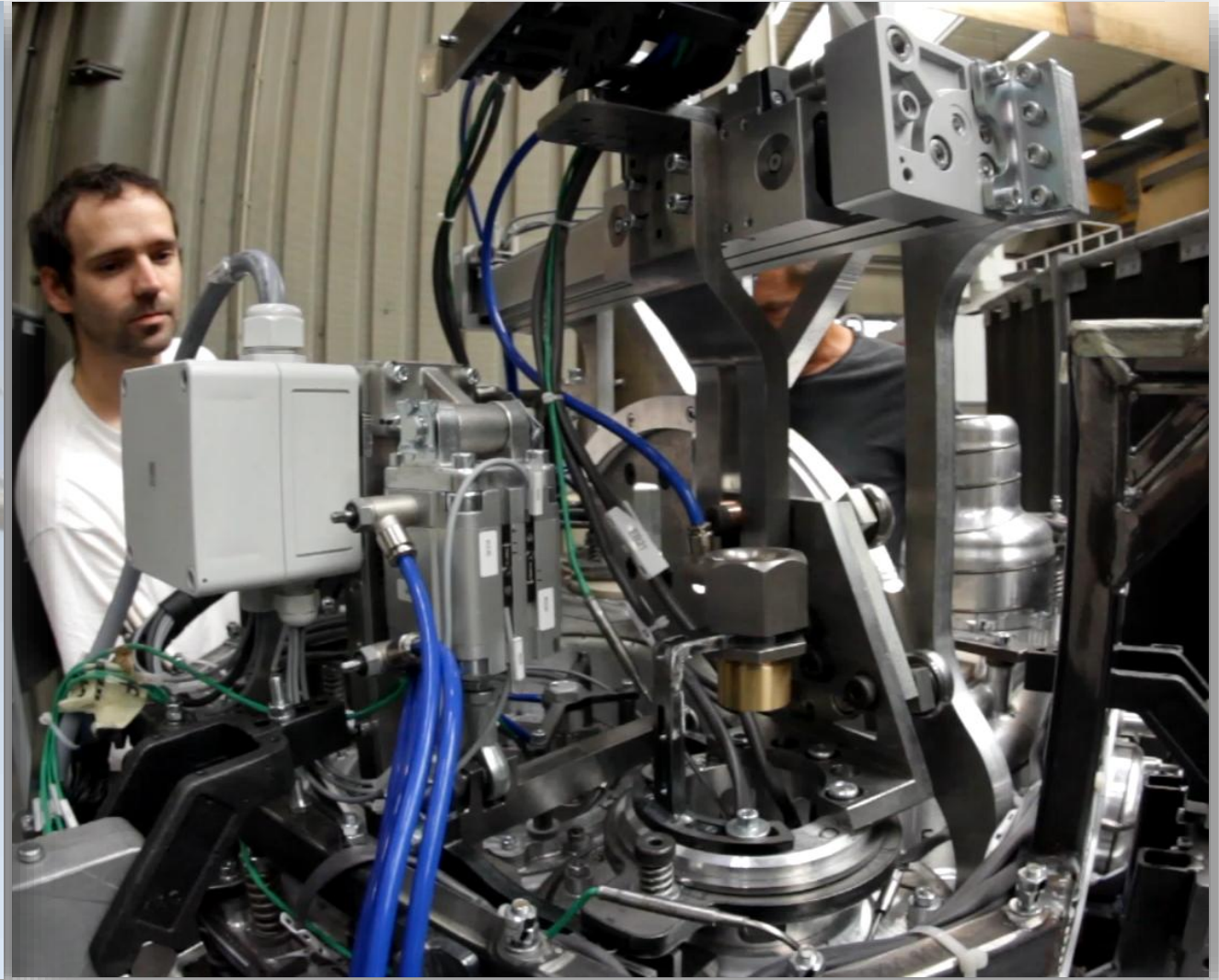
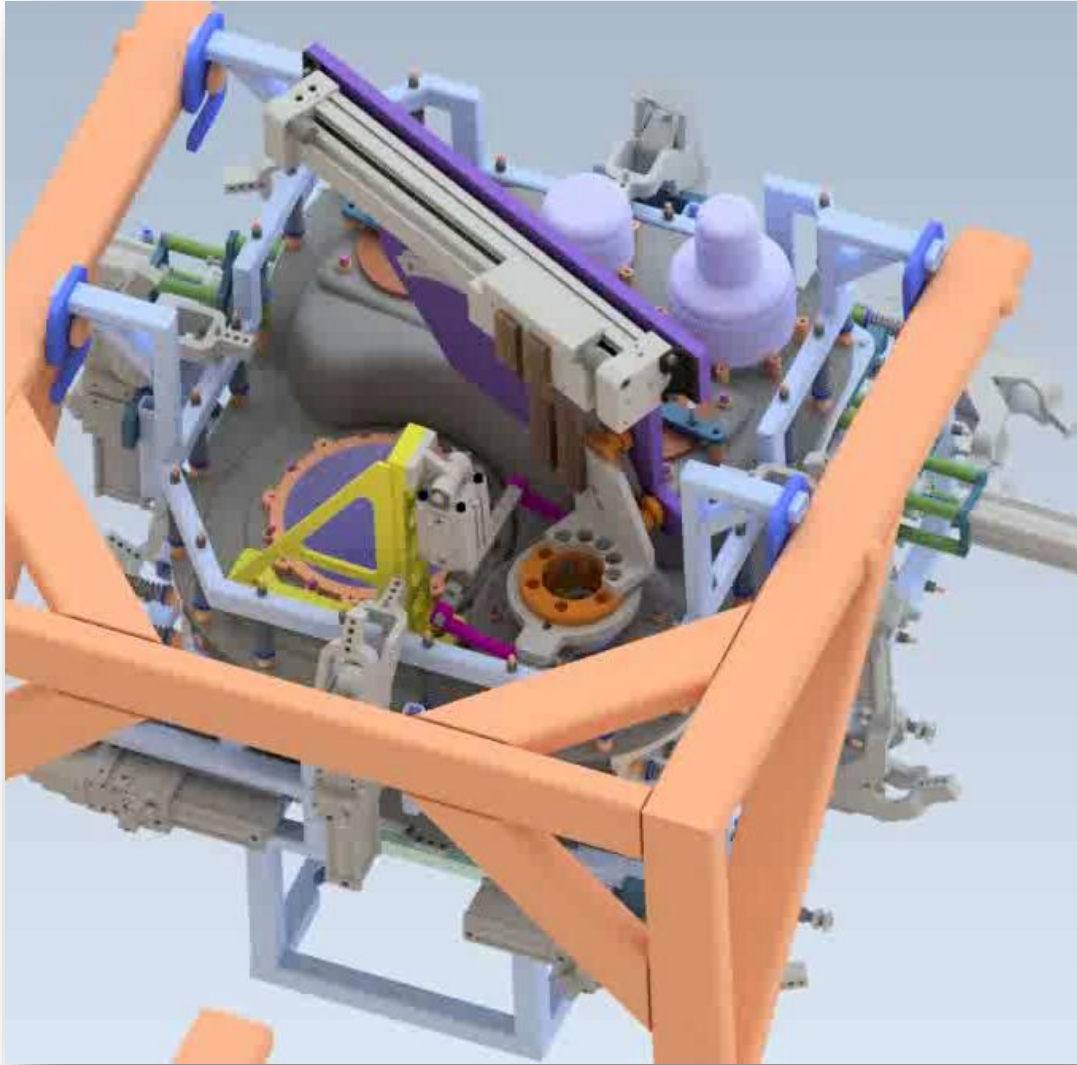



# Automatic retraction for Robomould

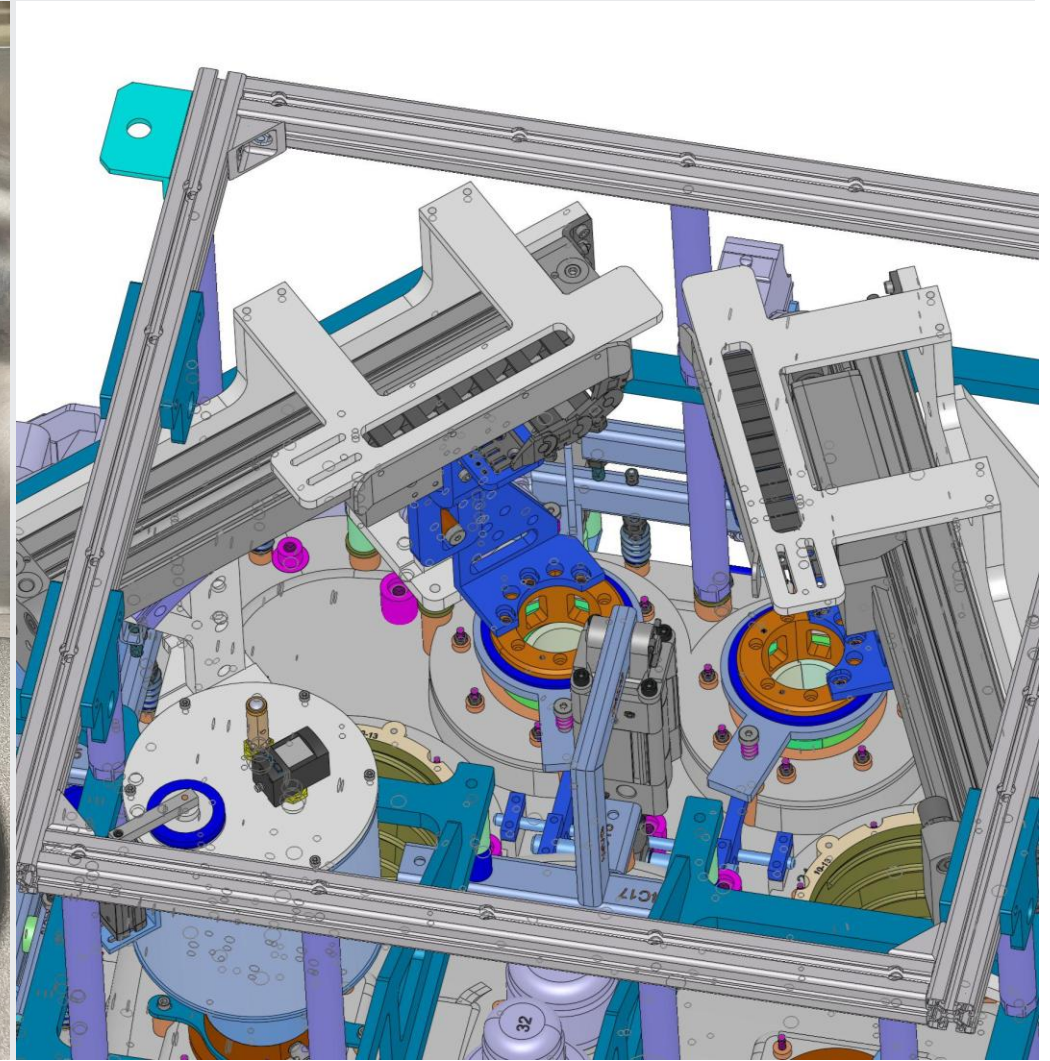



# Automatic retraction for Robomould

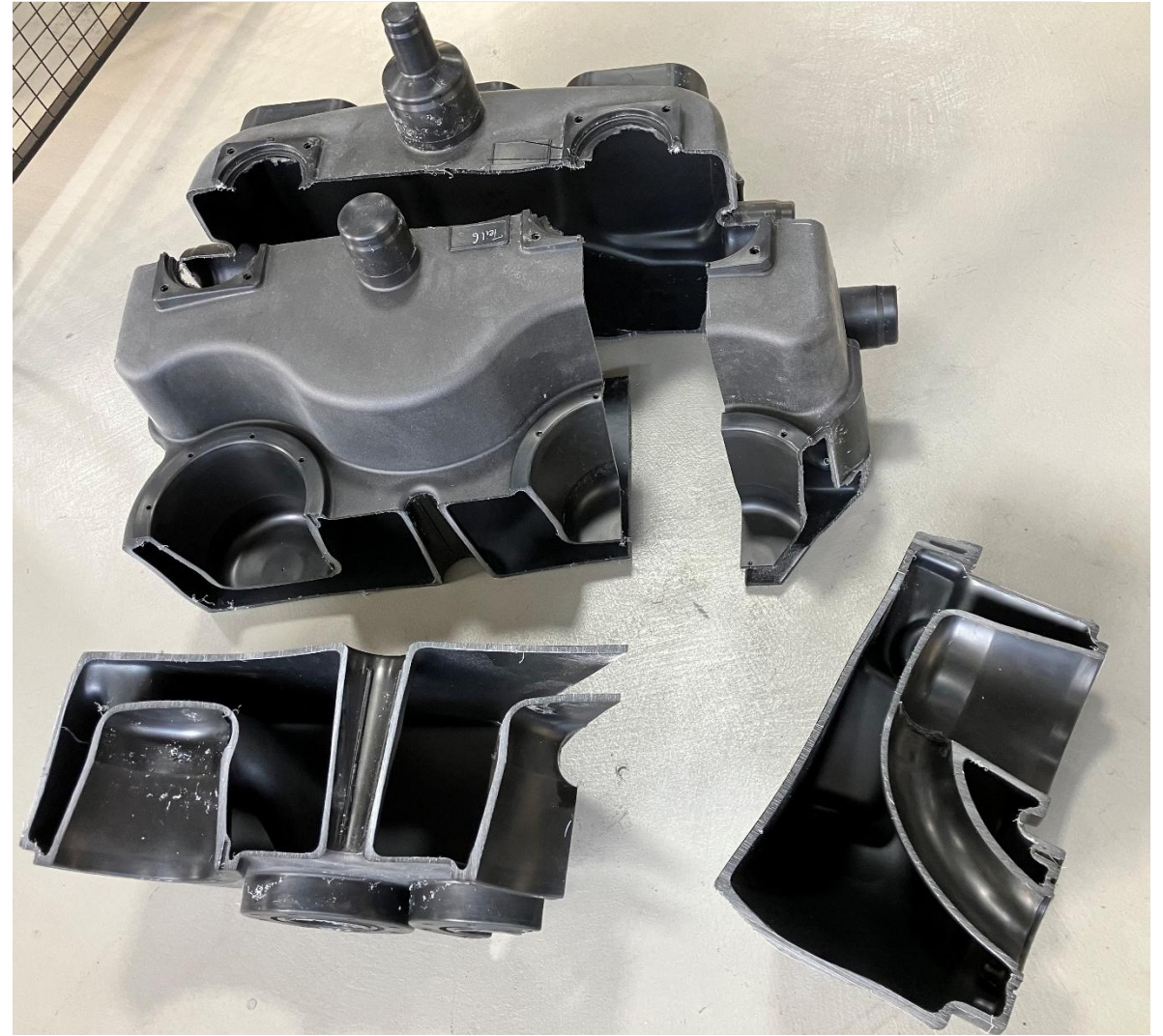
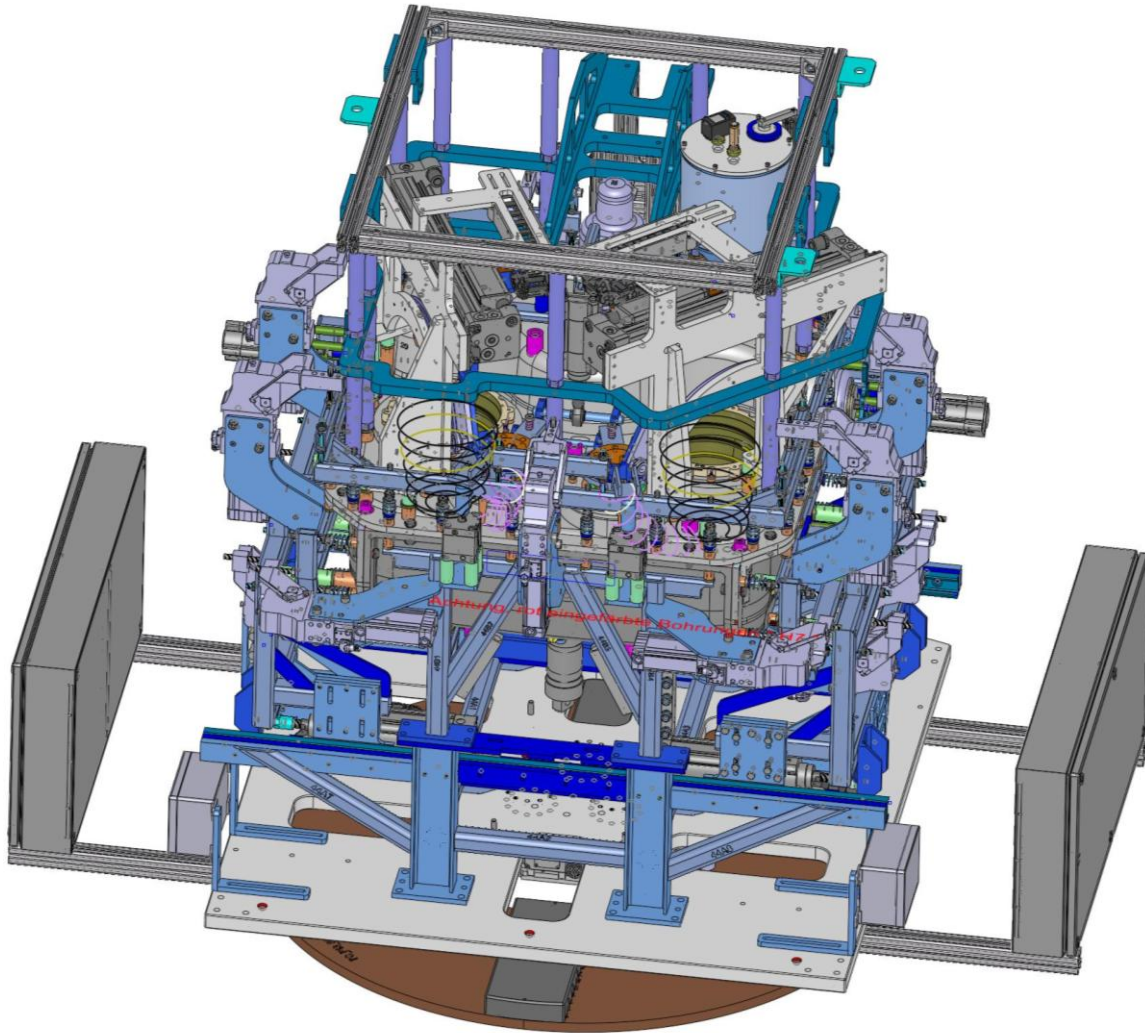

# Automatic mold change



# NEW – Multibox available for foaming - NEW

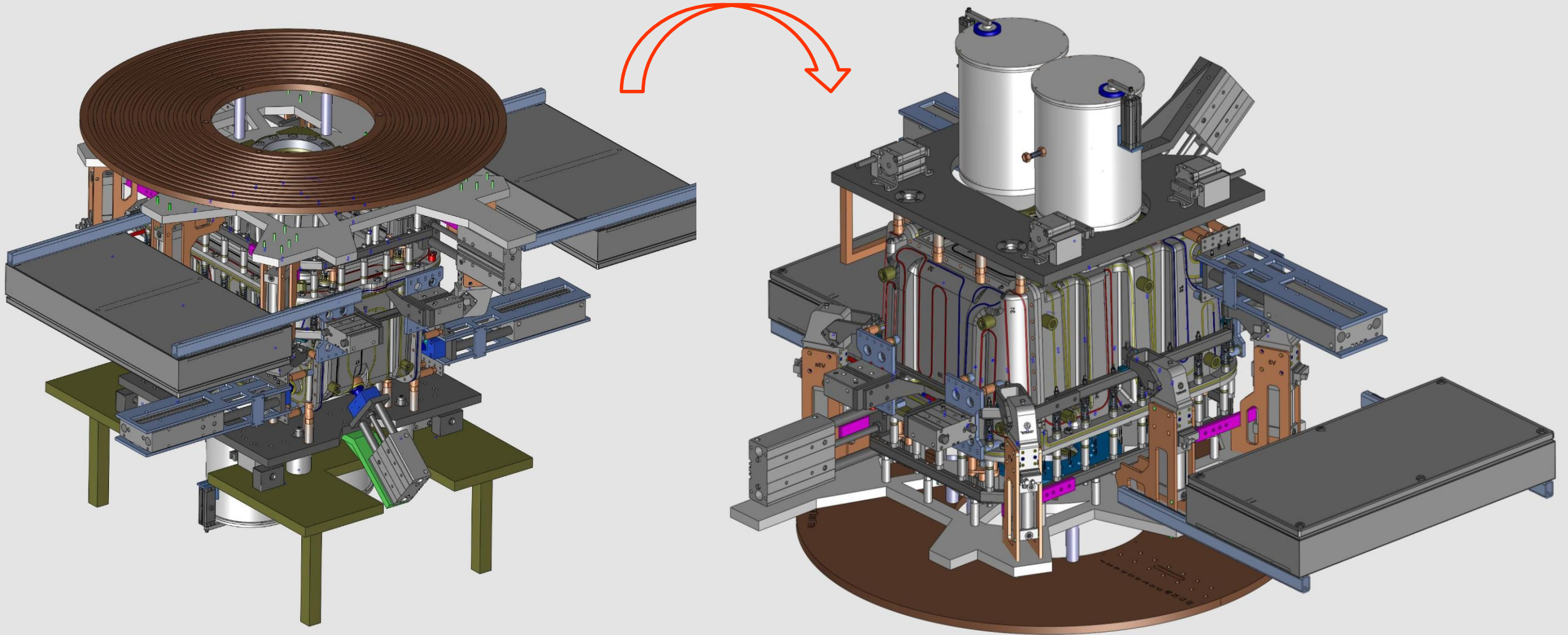
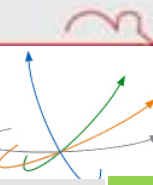



**Thank you for your attention**  
**Any questions?**

[oliver.wandres@maus-gmbh.de](mailto:oliver.wandres@maus-gmbh.de)

 +49 721 9487412

[www.maus-gmbh.de](http://www.maus-gmbh.de)

Webshop: [maus-gmbh.shop](http://maus-gmbh.shop)

***Maus***  
**ROTATIONSGIESSFORMEN**