

Rotomoulding at The Queen's University

In the beginning...

ARM Executive Forum

10-June-2026

Riddel Hall, QUB

Dr. Paul Nugent

Rotomoulding at QUB



What size of flak jacket do you need for your visit?

Rotomoulding at QUB

- ◆ 1980s How it All Started
- ◆ 1987 Guess Who Arrived?
- ◆ 1988 Searches, Software & Datalogging
- ◆ 1989 Rotolog
- ◆ 1989 The Connection with ARM begins
- ◆ 1990 More Machinery
- ◆ 1990s The Centre Grows

QUB History – “The 1990’s”

Roy’s Years at Queens

- 1966 Start undergrad degree
- 1970 Started PhD
- 1972 Lecturer - Dept of Mech. & Ind. Engineering
- 1982 Senior Lecturer
- 1984 Reader
- 1989 Professor and Director of the School of Eng.
- 1999 Departed for New Zealand - U of Auckland
- 2001 Returned to Queens as Pro Vice-Chancellor
- 2004 Departed for New Zealand again!



QUB History – “The 1990’s”

My personal Experience:

Alvin

12/1/93.

Could you please let me have a copy of all the graphs so far generated for your work. In particular the ones used for the display boards and the important ones from the reports for Lilaac/Waste or 1st year report.

I want to pull them together into a paper because I believe it is important to get your results into print.

Thank you
Ray.

PS We must decide about PPS conference before 1st Feb.

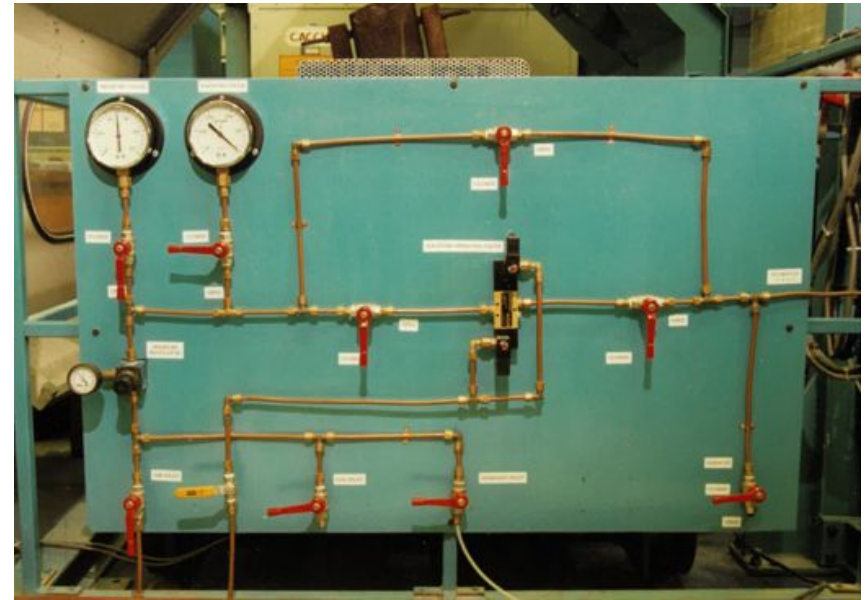
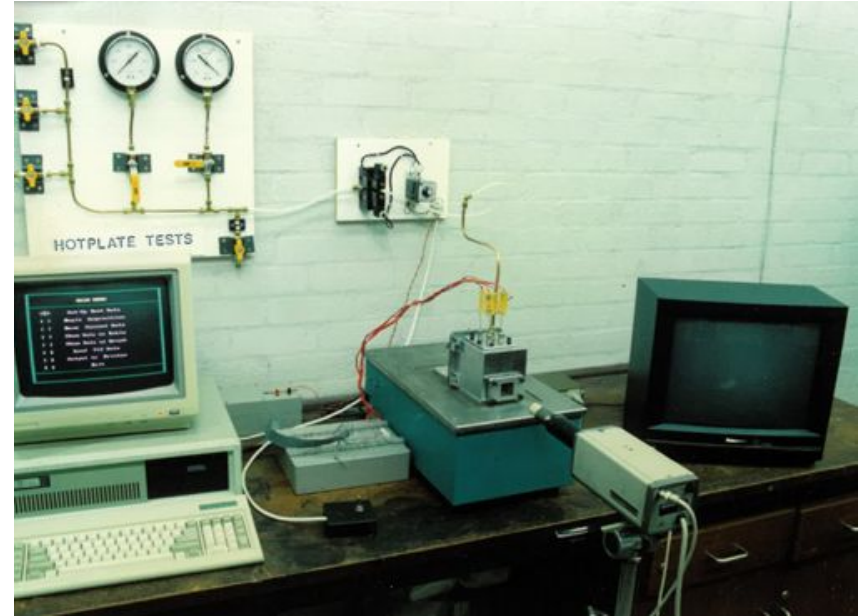

QUB History – “The 1990’s”

Some of the Researchers in the 1990’s

Paul Nugent
Eileen Harkin-Jones
Alvin Spence
Xi (Linda) Lang
Joe Butterfield
Brendan Wisley
Julia McDaid
Kevin Walls
Gareth McDowell
X.M. Wang
Da-Wen Sun

Joe Brendan Paul Alvin



Stephen

Kevin Mark Roy Linda

QUB History – “The 1990’s”

The PhD Research Work:

- A Study of the Effects of Processing Variables on the Properties of Roto Moulded Articles
- A Study of Heat Transfer and Process Control in the Rotational Moulding of Polymer Powders
- Rotational Moulding of Reactive Plastics
- Analysis of Bubble Formation and Removal in Rotationally Moulded Products
- Rotational Moulding of Thick Walled Products
- Improving the Mechanical Properties of Polyethylene using the Rotational Moulding Process
- The Development of Design Procedures for Rotationally Moulded Plastics
- The Grinding of Polymer Powders for use in Rotational Moulding
- Numerical Modelling for Rotational Moulding with Non-Isothermal Heating
- Analysis of Cooling in Rotational Moulding (sponsored by ARM)
- A Study of Warpage in Rotationally Moulded Parts (not sure of exact title)
- A Process Model for Rotational Moulding

QUB History – “The 1990’s”

The Sponsors:

- ESPRC – Engineering and Physical Sciences Research Council
- DSM
- Neste Chemicals
- Borealis
- Lin Pac Rotational Moulding
- Association of Rotational Molders
- Exxon
- Caccia
- Ferry Industries
- Kelch

QUB History – “The 1990’s”

Outputs & Publications:

- Research into the Rotational Moulding Process carried out over decades
- The Rotolog and K-paq temperature measurement systems
- Rotational Moulding of Plastics (book)
- A Practical Guide to Rotational Moulding (book)
- Hundreds of technical papers and presentations
- Many Rotation/RotoWorld contributions
- Strong involvement in ARM (Roy was the Technical Director until 2016)
- The creation of the Rotational Moulding Research Centre
- Hands on training courses – some with interpreters!!
- The creation of the Polymer Processing Research Centre

QUB History – “The 1990’s”

The Rotational Moulding Research Centre:

ROTATIONAL MOULDING RESEARCH CENTRE

ROTATIONAL MOULDING is the fastest growing sector of the plastics processing industry. Over the past decade, research work at Queen’s University in Belfast has raised the awareness of the process worldwide. This effort has now been consolidated with the formation of the Rotational Moulding Research Centre at Queen’s University.



This Centre is an independent unit which aims to:

- Provide a research and development service to companies worldwide.
- Act as a focus of interest in the process of rotational moulding beyond present users to a much wider audience of potential users.
- Ensure that a strong research commitment is maintained to examine fundamental aspects of the process for the widest possible benefit to industry.
- Establish standards for the development and testing of new materials and processing.
- Collaborate in projects for process and product development.

FACILITIES

OUR FACILITIES ARE BASED on full-scale industrial equipment which enables direct correlation with results obtained by commercial moulders and suppliers. We can investigate all the major aspects of the rotational moulding process from formulating materials, through grinding and moulding to testing of final product.

— MOULDING EQUIPMENT —



COMPOUNDING

A MAJOR addition to the Centre is a co-extrusion unit with a compounding and granulating head. This will allow us to work with the basic formulation of the materials used in moulding. It will also allow more detailed work on reprocessing of materials.

GRINDING

A SINGLE STAGE grinding mill from WEDCO is used to produce powders for moulding projects. This is a small to medium batch unit which enables us to examine samples of new or untried materials whilst at the same time ensuring the capacity to produce sufficient quantities for extensive moulding trials.



MATERIALS TESTING

IMPACT TESTING



DARTEC



TESTING OF MATERIALS before and after processing is fundamental to quality control and consistent research. The Centre has a full complement of test facilities including:

- Instrumented drop-weight impact testing (Rosand)
- Flexural and tensile testing (Dartec)
- Melt Flow Rate and powder flow testing
- Sieve analysis for powder particle size distribution
- Hotplate testing for video analysis.

SIEVING ANALYSIS



MFR



With the University as a setting, the Centre staff have access to a much wider array of equipment including:

- DSC
- TMA
- TGA
- Electron Microscopy
- Image processing equipment

QUB History – “The 1990’s”

The Rotational Moulding Research Centre:



QUB History – “The 1990’s”

Hands-on Training Courses:

Rotational Moulding Training Course

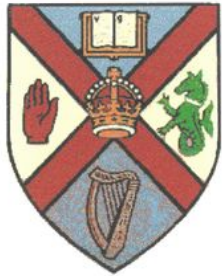

*The Queen's University
of Belfast*

*10th - 12th June
1996*



Rotational Moulding @ Queens

- Over 35 years of expertise in rotational moulding technologies and materials.
- Recognised as a Global Centre of Excellence in rotational moulding innovation.
- Portfolio of patents demonstrating leadership in innovation, research and development.
- Industrial-scale manufacturing capabilities using both gas oven and direct electric rotational moulding systems.
- Advanced material testing infrastructure, including pulverisation and characterisation equipment.
- Ability to analyse, optimise, and innovate with materials for enhanced performance and quality.

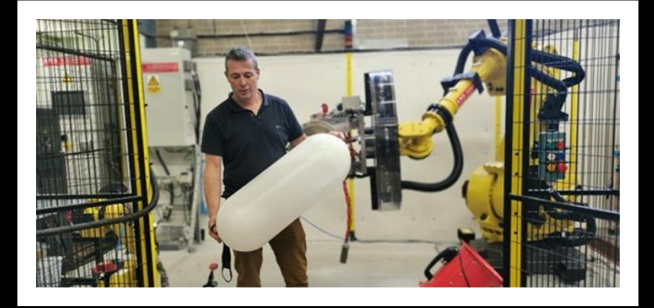

Micromelt Project

The Development Of Advanced Retro-Fit Processing Technologies For Rotational Moulding To Reduce Product Cost and Processing Time and Increase Surface Quality Start Date: 1st September 2006 / Finish Date: 31st August 2009
Total Project Value €2.55m

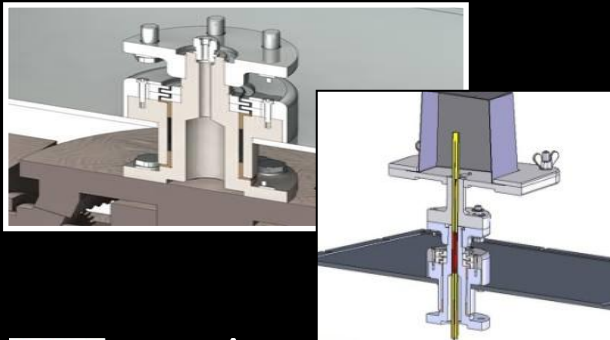
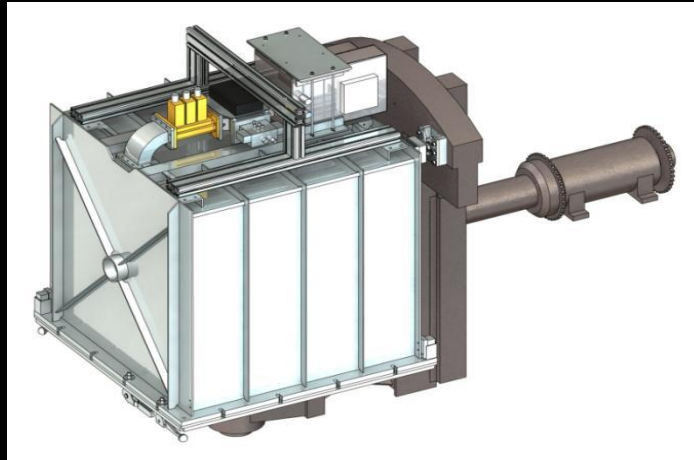

ADVANCED
MANUFACTURING
INNOVATION
CENTRE

Rotoflex Project

'Innovative rotomoulding development to improve cycle times and process efficiency whilst facilitating greater flexibility in product design and integrity for the SME-rotomoulding sector' Start Date: 1st January 2009 / Finish Date: 31st December 2011
Total Project Value €1.23m

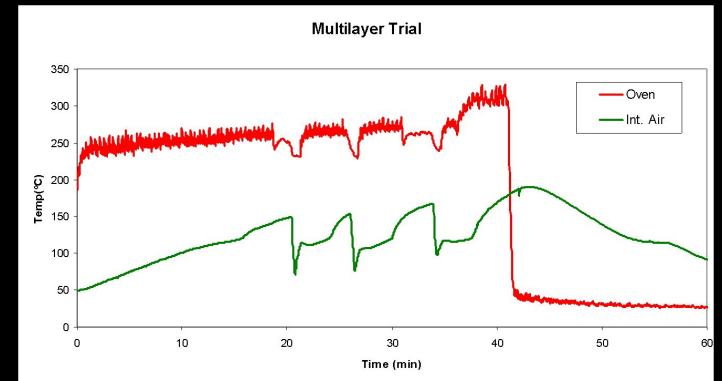
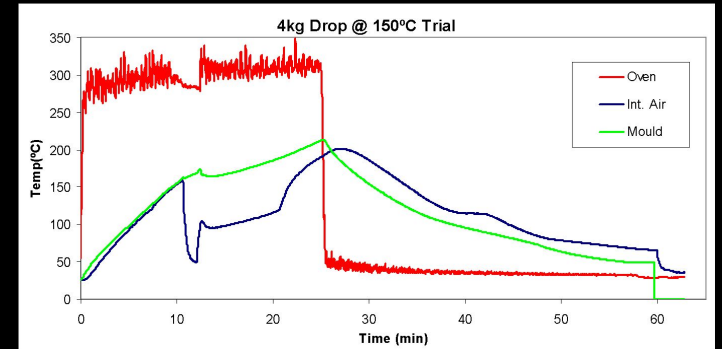
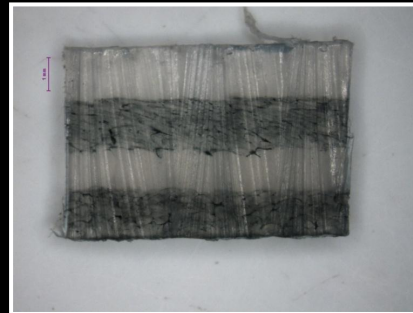
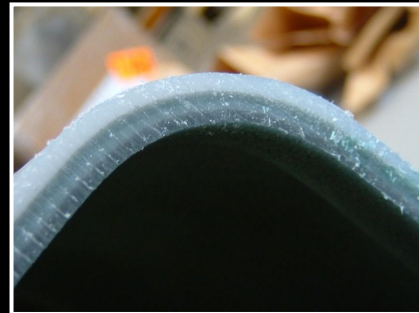
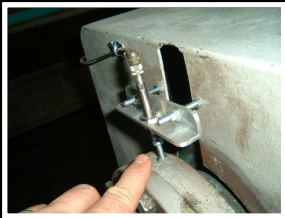

ADVANCED
MANUFACTURING
INNOVATION
CENTRE

Rotofast Project

ROTOFAST (FP7-SME-2008-243607) - Development of an efficient heating and cooling technology system for traditional moulding, which will dramatically reduce cycle time, product cost and energy consumption

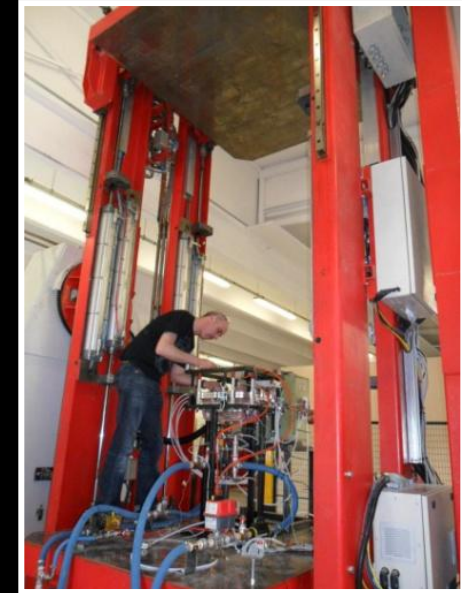
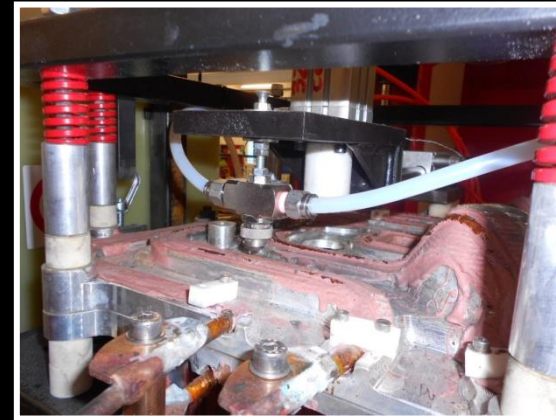
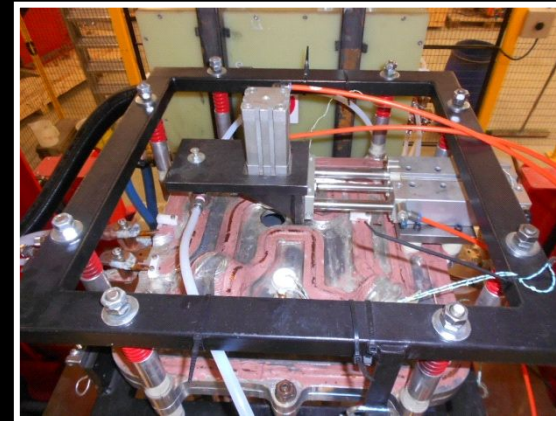
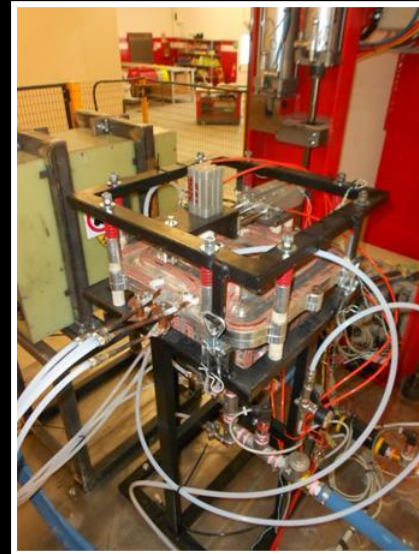
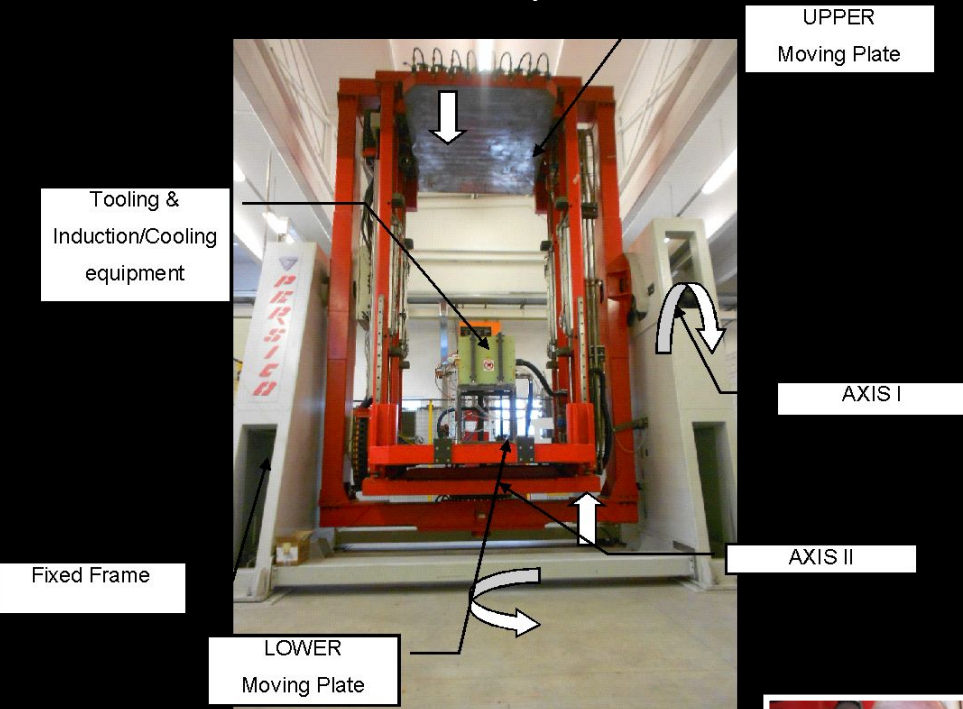

Internal Water Cooling Project

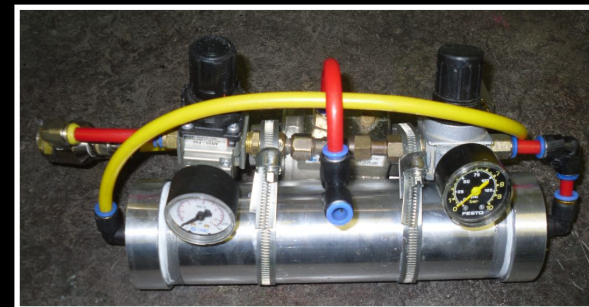
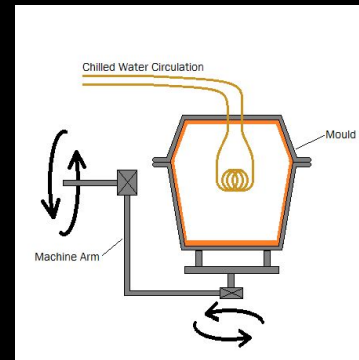
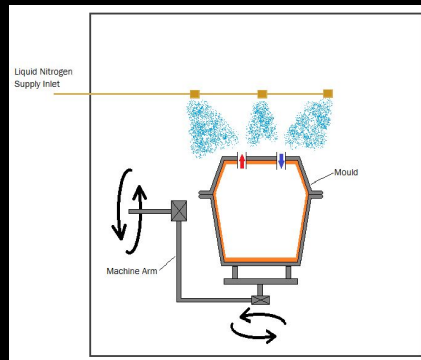
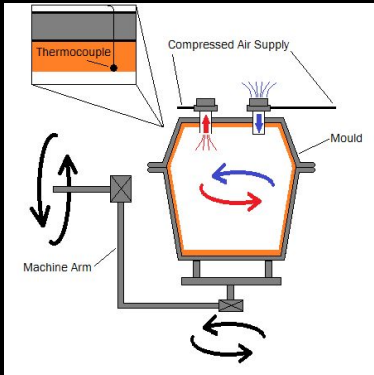
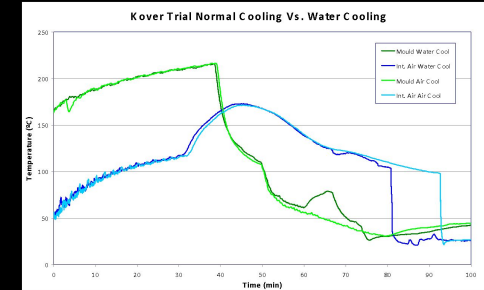
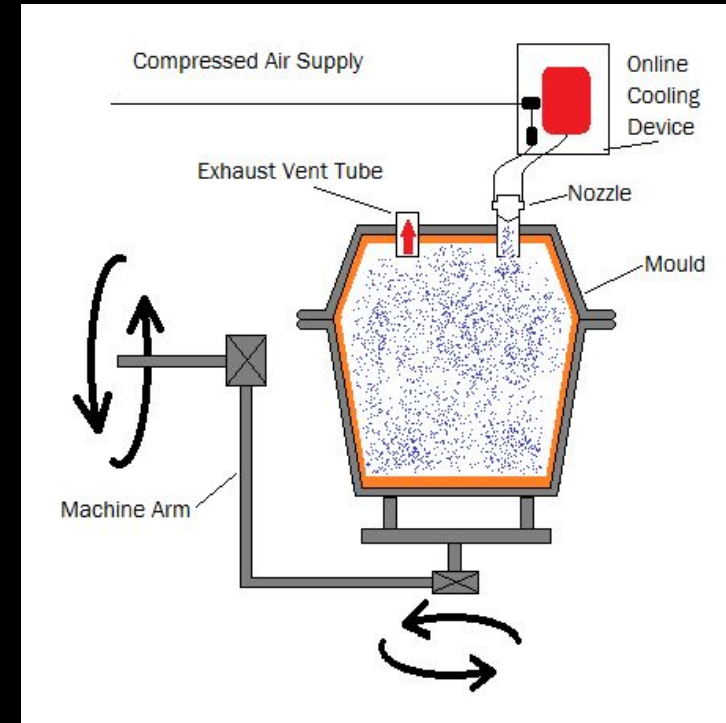
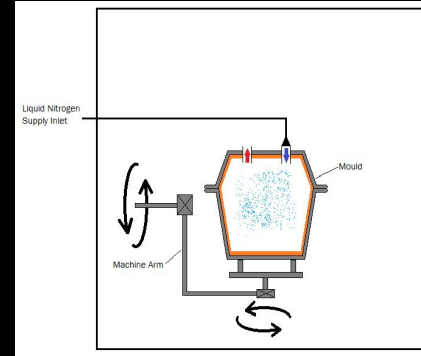
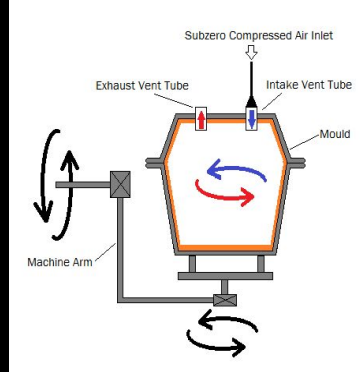
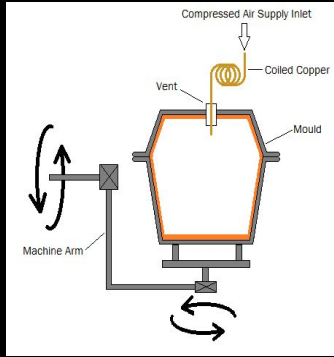

Internal Water Cooling Project

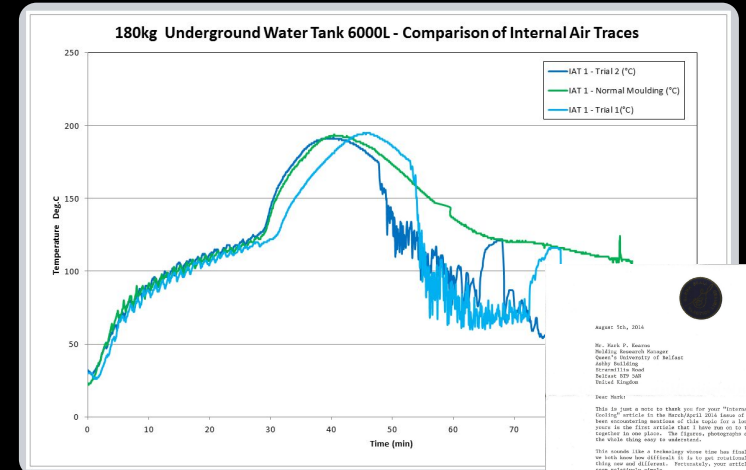
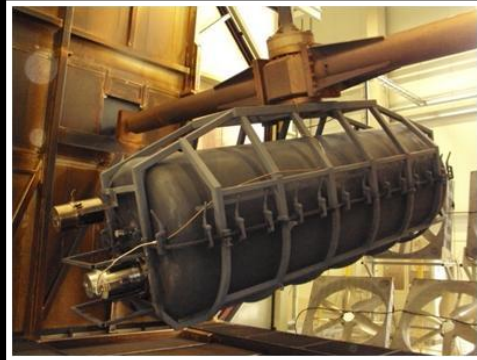
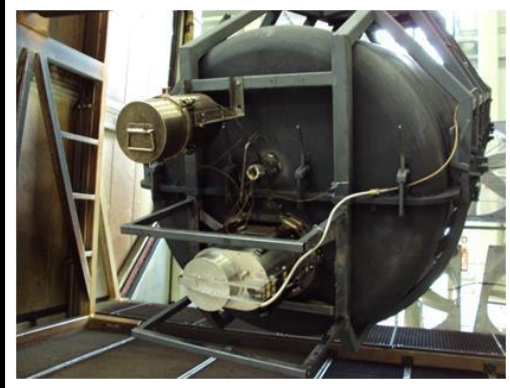
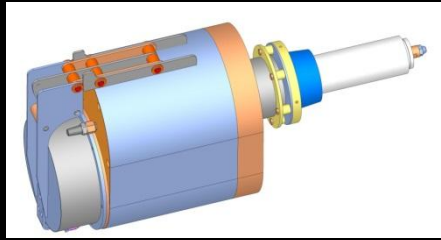

August 5th, 2016

Dr. Paul P. Sweeney
Building Research Institute
Queen's University of Belfast
Stranmillis Road
Belfast BT9 5EX
United Kingdom

Dear Sir,

This is just a note to thank you for your "Internal Water Cooling" article in the May/June 2016 issue of "Manufacture". It was most interesting to read of the issues that you have identified with the current state of the art and the need for a new technology to address these issues. The figures, photographs and the chart make the article much more readable.

This sounds like a technology whose time has finally come. Unfortunately, we have been too slow to get involved, unless you agree something new and different. Fortunately, your article makes the problem more readable.

Thank you for alerting the information.

Sincerely,
Gavin G. Hall

G.G.H.

© 2016 N. New Road Libertyville, Illinois 60089-4202 Phone 815/461-0101 FAX 815/461-0866

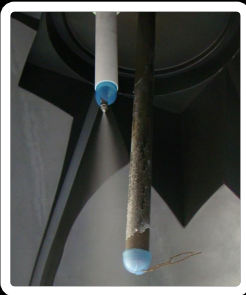
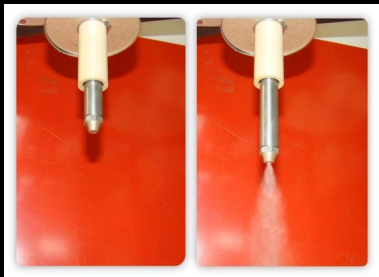

Total Energies Project – 20 years



- Rotomoulding Material Development
- Fundamental rotomoulding material understanding and design
- Process Development
- Foam / multi-layer
- Bio-materials
- Micropellets
- Polypropylene / Polyamide / Engineering Polymers
- Composites
- Joint Presentations / Conferences / Industry visits

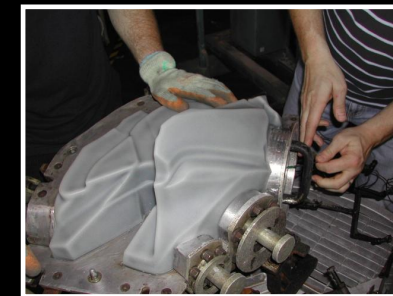
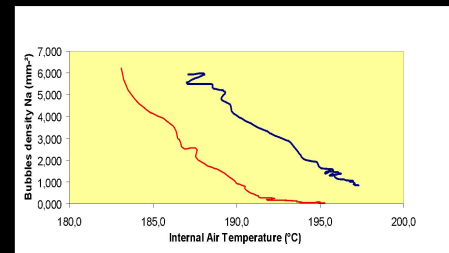
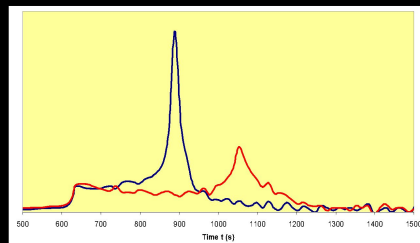
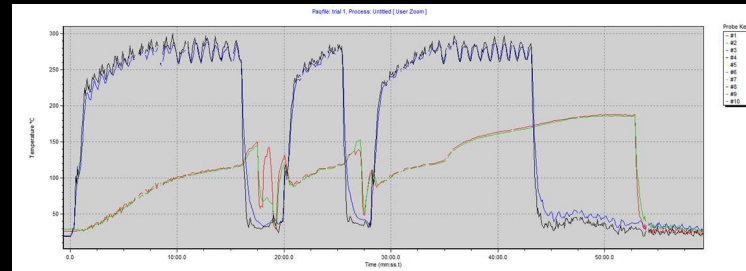
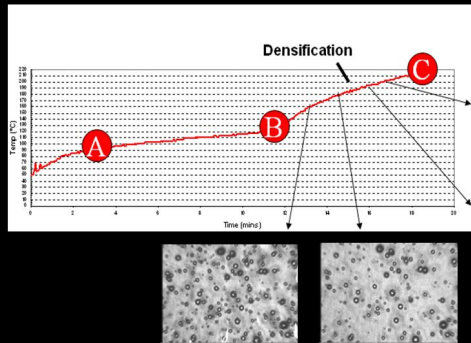
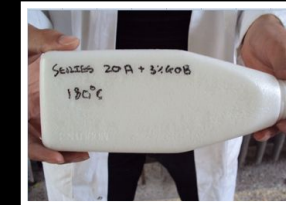

ADVANCED
MANUFACTURING
INNOVATION
CENTRE

AMS Robomould – >10 years

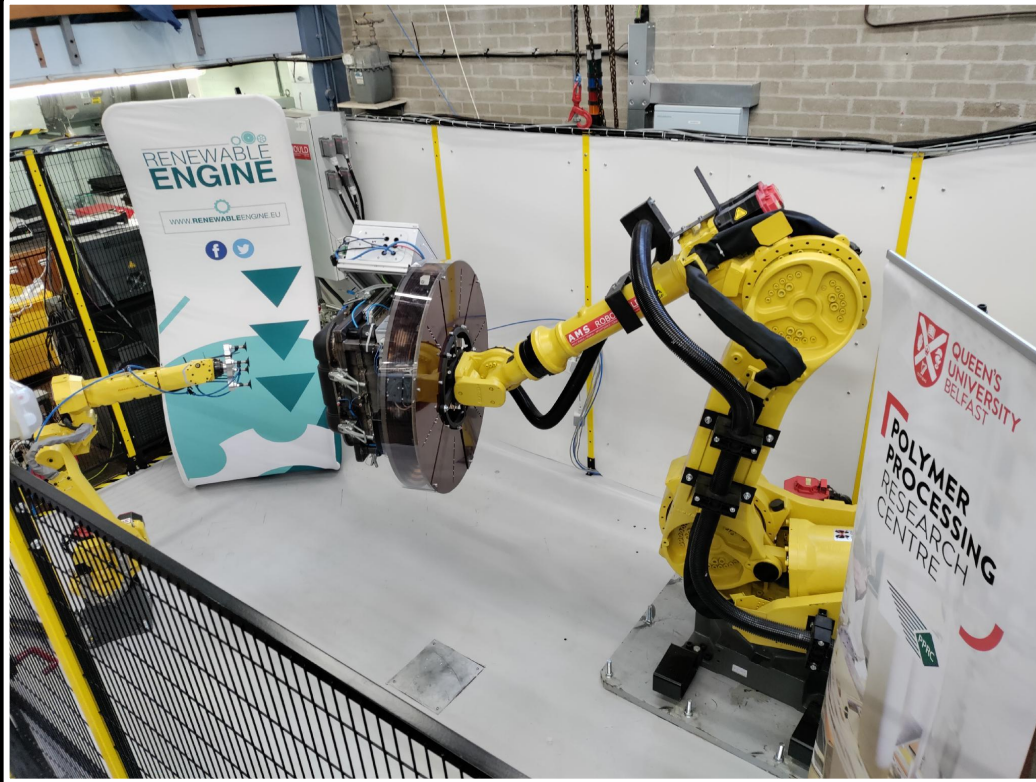

Liners for Hydrogen Storage

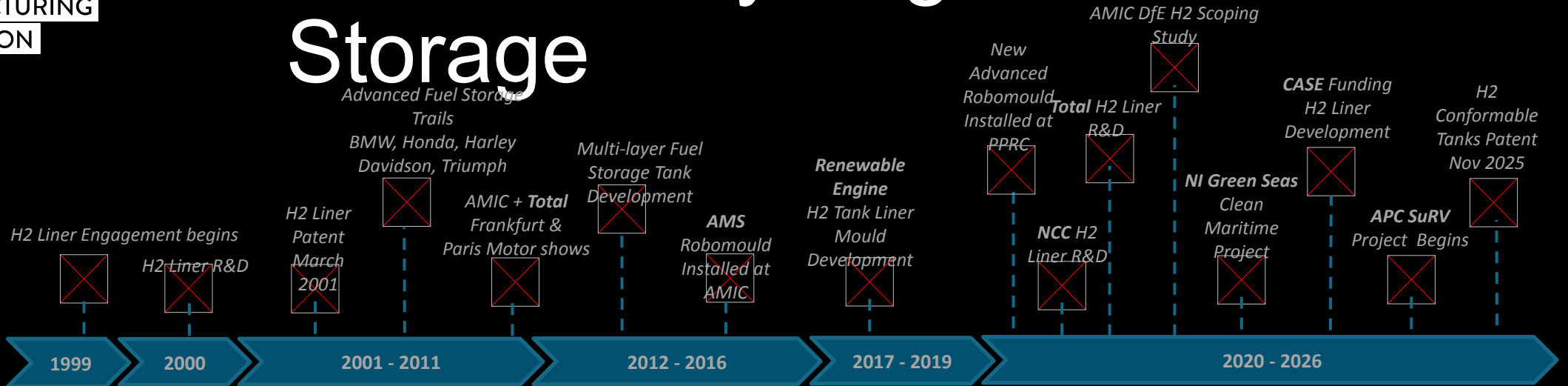

1999 PPRC R&D begins on Rotomoulded Type IV Liner Development – ENSAM, CEA, France

1999 Major 20+ year Rotomoulding R&D begins with Total Energies, Belgium

Development of advanced high gas barrier storage vessels - materials and process optimisation

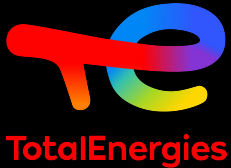

2016 Renewable Engine Project Begins – Development of Hydrogen Liner Tool for Robomould



2016 Establishment of Advanced Robotic Rotomoulding Cell at AMIC

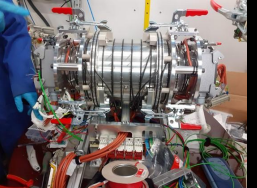
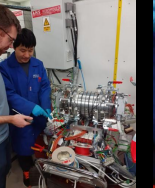

- 2025 - 2026 INI PoC Conformable Hydrogen Tanks R&D
- 2025 2nd Patent Application - Conformable Tanks (GB Patent Application No. 2518317.9)
- 2023 - 2026 NCC / Rolls-Royce Engines – Liner R&D
- 2023 AMIC DfE Report completed – Scoping Study 'Cryogenic Hydrogen Opportunities in NI'
- 2022 Innovate UK APC funded Award SuRV (Scale Up Readiness Validation) on Hydrogen Polymer Liners (£2.6m)
- 2022 Hydrogen Storage material development with Total Energies, Belgium
- 2022 AMS funded QUB PhD on Liners / AMS Robomould
- 2021 AMIC DfE NI 'Hydrogen Technology Scoping Study'
- 2021 Industry sponsored CASE Project H2 Liner development (£1.3m)
- 2021 CITI-GENS PhD using Robomould (AMS Robotics, Belgium)
- 2021 Ongoing Direct funded work with NCC on H2 rotomoulded liners
- 2021 UKRI 'Clean Maritime Demonstration Competition' Hydrogen for Marine Applications (£0.8m).



ADVANCED
MANUFACTURING
INNOVATION
CENTRE

ARM Training Courses – US / Canada / UK

Equistar – Cin 1999 / Chroma - Chicago 2004 / Nova - Clagary
2005

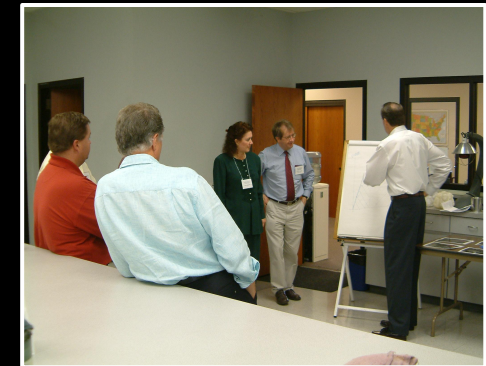
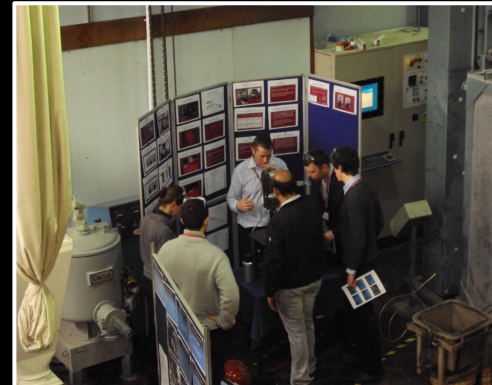

ADVANCED
MANUFACTURING
INNOVATION
CENTRE

ARM QUB Training Courses

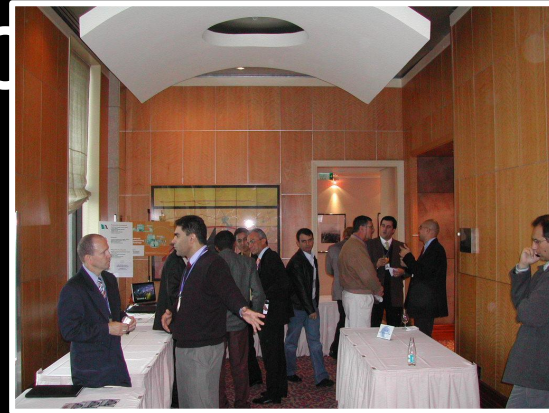

ARM Meetings – QUB Exhibits / Presentations at Rotoplas

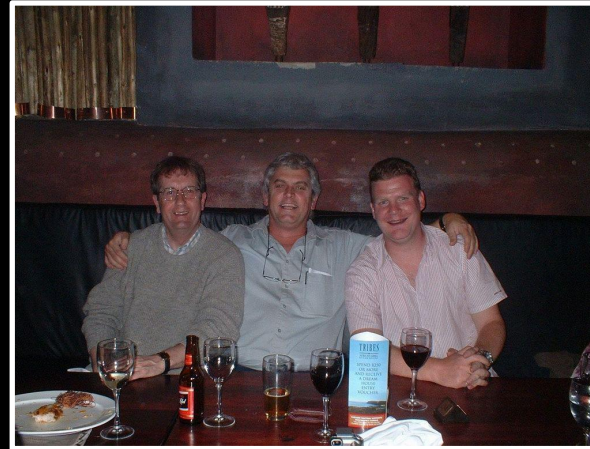

Rotation / Rotoworld QUB Articles

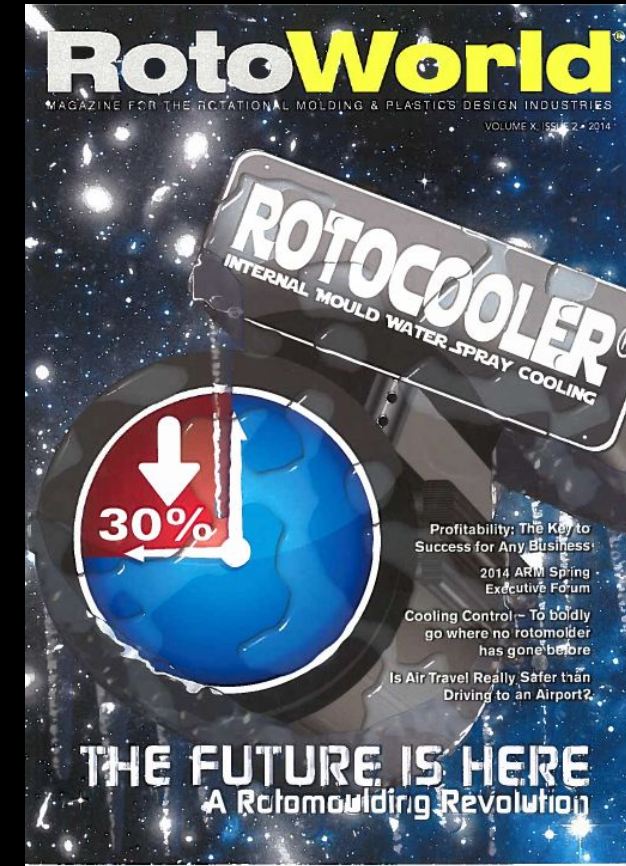

Rotomoulding Books

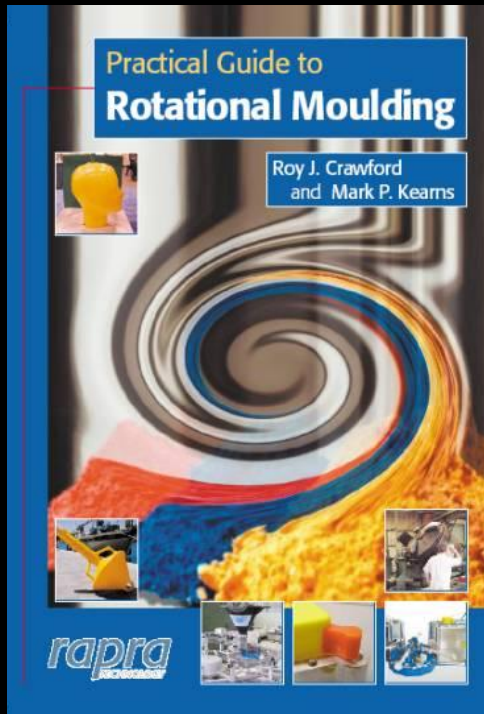

2003

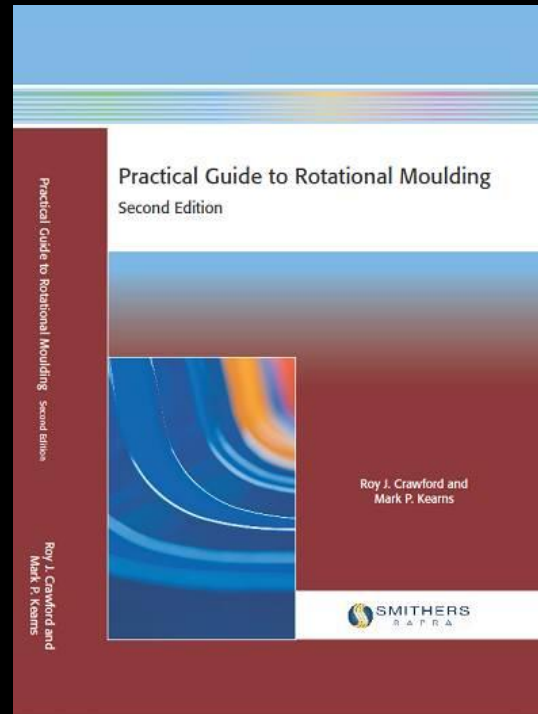

2012



2021

Visitors to QUB Rotomoulding



Visitors – Ministers of State, VIPS, (Former)
Royalty