

CTRL UL101
Ultrasonic Inspection System

Operator's Manual

© Copyright 2018 CTRL Systems, Inc.

All rights reserved. Copying, duplicating, or otherwise distributing this document, in whole or part, without written permission of the publisher in any media is violation of federal copyright law.

The information contained in this document is subject to change without notice. CTRL Systems shall not be liable for errors contained herein or for consequential damages in connection with the furnishing, performance, or use of this material.

CTRL, the CTRL logo, CTRL UL101, InCTRL and PowerBeam 300 are the property of CTRL Systems, Inc.

Introduction	1
Registration Information	1
Product Overview	2
Advantages of Ultrasonic Inspection with the CTRL UL101	2
Product Features.....	2
Ultrasound Overview	3
Components.....	4-6
CTRL UL101 Receiver, Transmitter, and Components.....	7
CTRL UL101 Controls.....	8
Getting Started	9
CTRL UL101 Set-up Procedure	9-10
Typical Applications	11
Tips & Techniques	12
Operating Techniques.....	12
Operating & Technical Tips.....	13
Adverse Operating Conditions	14
Important Safety Information	15
General Info	16
Maintenance and Care.....	16
Expected Battery Life	16
Determining if Batteries Need to be Changed.....	16
Replacing Batteries	17
Warranty and Repairs	17
Additional Resources	18
Product Support.....	18
Product and Technology Training	19
On-site Training	20
Condition-based Monitoring Products	21-22
Corona Discharge & Electrical Arcing Products	23
Products & Accessories	24

Special Note:

Please read this manual in its entirety to obtain a good understanding of how to test with the UL101. It is also highly recommended that the user take advantage of additional support and training available through CTRL.



For your safety, please take special note of the Safety Information on page 15, as well as any section marked with the symbol shown at left.

Thank you for purchasing the **CTRL UL101 Ultrasonic Inspection System** (UL101). You have made the right investment for the operational, maintenance, and quality control needs of your organization. When used on a regular basis, the UL101 is a valuable tool for diagnosing potential problems, identifying cost saving opportunities, and increasing production and profit.

The UL101, originally designed for the U.S. Military, is now used in several industries throughout the world for **condition-based monitoring, quality control, and leak detection**. The UL101 Receiver detects and converts ultrasound signals produced by industrial machinery and vehicles into easily recognizable audible sounds (within the human range of hearing) so the user can evaluate the operating condition of bearings and gears, detect pressure or vacuum leaks, and identify electrical problems, such as corona discharge – even in extremely noisy plant environments.

Tightness and integrity testing can also be performed on non-pressurized tanks, lines, pipes, and other vessels with the UT2000 Universal Transmitter (included in the CTRL UL101 Full Kit).

With the CTRL UL101, early warning signs and defects can be detected – thus preventing costly repairs, safety-related injuries, and downtime.

It is the goal of CTRL Systems, Inc. that you receive the highest return on investment for your purchase of this system and that it makes your daily maintenance and operations activities easier. This manual is designed as a complimentary resource to the Technology Training CD that you received with the UL101. On-site training is a great way to introduce ultrasound technologies to your team. See page 20 for details.

Important Product/Warranty Registration Information

To register your product and activate the warranty coverage, complete the registration card that was included with your system and return it to CTRL, or register online at www.ctrlsys.com/community.

When you register, you will automatically become a member of the CTRL Online Community and will have access to online support, tips, and downloads.

What is Ultrasound?

The UL101 Receiver uses the properties of ultrasound for inspection. Ultrasound is sound with a frequency above the human hearing range. Humans can hear sound with frequencies between 20 Hz (Hertz) and 20,000 Hz. Ultrasound is all sound above 20,000 Hz and cannot be heard by humans. Ultrasound is created when there is:

- Vibration
- Impact
- Turbulence
- Friction
- Electrical arcing or corona discharge

The UL101 Receiver has a reception with the center of frequency at 40 kHz, the optimal frequency for listening for different kinds of industrial defects. The CTRL UL101 converts ultrasound into audible sound so the user can diagnose the condition of critical equipment. The primary properties of ultrasound that make it useful for diagnostic tools are the following:

- Rate of Attenuation – Ultrasound has a high frequency and accordingly shorter wavelength, therefore ultrasound waves attenuate more quickly than sound waves and do not travel as far as audible sound.
- Directionality – The reception of ultrasound waves with the UL101 Receiver is directional, which allows the user to pinpoint the exact location of the problem.
- Shielding - Ultrasound waves in air can be easily shielded and do not travel easily around corners.
- Early Detection - Ultrasound can be detected prior to audible sound, allowing problems to be detected earlier than with other methods.

These properties allow the user to distinguish and isolate the ultrasound of individual components and leaks for better equipment diagnosis. For example, if there are two bearings that are next to each other, because ultrasound attenuates rapidly, it allows the user to listen to each bearing individually. If the user is looking for a gas leak and other ultrasounds are competing, a simple piece of cardboard typically allows the user to block competing sound so that only leaks in the area being tested are heard. It is also possible to then pinpoint the exact source of the leak because of directionality.

PRODUCT OVERVIEW

CTRL UL101 Component Description

UL101 Receiver

- Handheld sensor detects and electronically converts ultrasound into easily recognizable sounds within the human range of hearing.
- Supplies output to a headset, as well as to an analog meter.
- Detects ultrasound from a greater distance with a higher signal-to-noise ratio than any other sensor on the market today.
- Easy-to-use controls include output switch, gain mode switch, and potentiometer.
- Lightweight and durable.
- Operates on one 9-volt battery for approximately 45 hours of continuous use.



UT2000 Universal Transmitter

- Used to detect seal, gasket, and weld defects in non-pressurized systems or enclosures.
- Generates an ultrasonic signal that fills a non-pressurized vessel, line, or cavity with ultrasound, creating ultrasonic pressure that can be detected with the UL101 Receiver when leaks are present.
- Can be injected into an air system in order to test for leaks, thus eliminating the need to run an air compressor during an air survey.
- Simple on/off control switch.
- Operates on a single 9-volt battery for approximately 300 hours of continuous use.

Advantages of Ultrasonic Inspection with the CTRLUL101

- Predictive - Provides the earliest warning signs of failure.
- Extrasensory - Detects many problems that cannot be heard audibly.
- Instantaneous - Provides useful, real-time information.
- Accurate - Allows the user to distinguish and isolate the ultrasound signal of individual components and leaks.
- Versatile - Can be used to test a wide variety of systems and components from bearings to non-pressurized vessels.
- Non-Destructive - Causes no adverse effect or interference; testing can be performed while equipment is operating.

CTRL UL101 Features

- Unmatched sensitivity, signal-to-noise ratio, and selectivity.
- Provides the capability for diagnosing component and system faults.
- Designed for a wide range of applications from bearing analysis to leak detection.
- Non-destructive; can be used while equipment is operating.
- Convenient, hand-held design for ease of use.
- User-friendly controls include potentiometer for on/off power and sensitivity adjustment; output switch; and gain mode switch.
- Dual-mode analog meter for ultrasonic signal and battery level indication.
- No calibration or special maintenance required.
- Operates on a single 9V alkaline battery for approximately 45 continuous hours.
- Extruded aluminum case maximizes tool life in harsh environments.
- Includes several attachments for testing in contact and scan mode.
- Selectable length probes increase the reach for testing.
- Compatible with InCTRL, CTRL's online condition-based monitoring (CBM) software. Provides signal logging, benchmarking, trending, reporting, and email alerts.

* InCTRL is sold separately from the CTRL UL101. For more information call CTRL Systems (1.410.876.5676) or visit the CTRL website (www.ctrlsys.com)

CTRL UL101 Key Components *continued*

Headset

- Industrial grade headset allows the user to hear converted ultrasound from the Receiver.
- Reduces or masks ambient audible sounds so user can distinguish ultrasound from the component under test.
- Available in over-the-head or behind-the-head (for use with hard hats) models.



Concentrator Set

- Self-threaded, high-grade plastic attachments increase the scope and precision of the UL101.
- Designed for scan mode to detect airborne ultrasound created by gas/air leaks, and bearings, gearboxes, and steam traps when necessary.
- Includes the Large Concentrator, Mini-Concentrator, and Acoustic Tip.
- The conical shaped Large Concentrator more than doubles the distance of the reception of ultrasound for detecting leaks and narrows the focus of reception from approximately 45° from center to less than 5° from center.
- The conical shaped Mini-Concentrator narrows the area of reception to 5° from center, blocking competing ultrasound and improving accuracy for pinpointing specific failures. Also provides added convenience for inspection in hard-to-access areas.
- The Acoustic Tip (inverted concentrator) increases the accuracy of pinpointing airborne ultrasound from a short distance. Recommended for small leaks, including vacuum, in suspected areas. Also used for shielding in noisy areas.



One-Inch Acoustic Probe

- Narrows the field of signal reception in scan mode.
- Can be used with the UT2000 Universal Transmitter to inject ultrasound into non-pressurized vessels, cavities, and pipes.



UL101 Receiver and Components

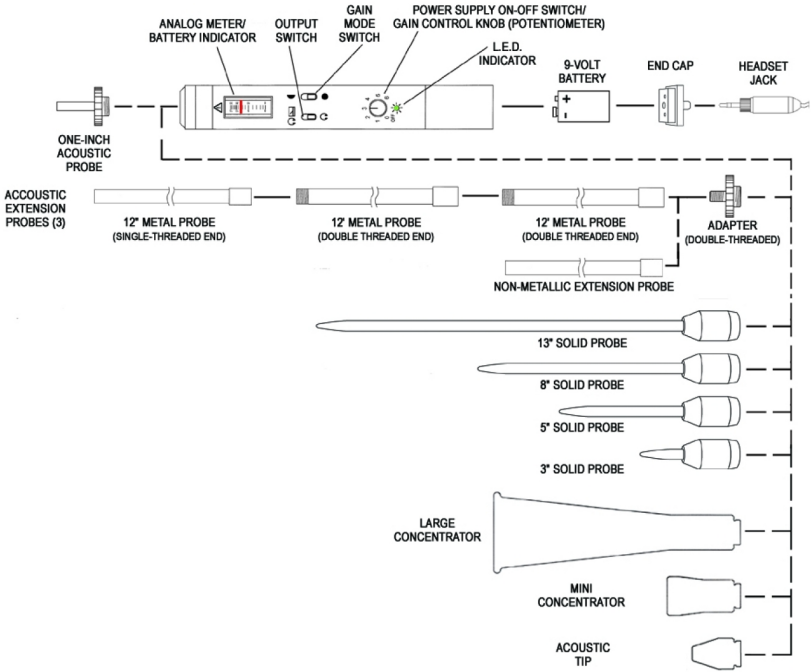

UT2000 Transmitter

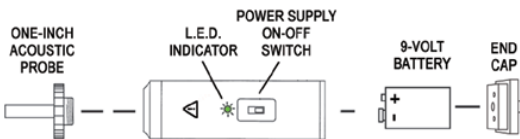

PRODUCT OVERVIEW

CTRL UL101 Controls

Controls on the **UL101** are easy to use. They allow the user to adjust the Receiver settings for exceptional **sensitivity** (ability to pick up faint ultrasounds), **selectivity** (ability to separate and reduce audible signals and noise from ultrasound signals of unit under test - plus the ability to differentiate between sources of ultrasound) and **discrimination** (ability to identify differences in operating conditions).

- Analog Meter: Indicates intensity of received ultrasound when the Meter Selector Switch is in the Meter/Headset position. When the Meter Selector Switch is in the Headset Only position, the meter becomes a battery tester.
- Potentiometer (Power Supply On/Gain Control Knob): Turns the unit on and off, and adjusts the sensitivity of the receiver to the range of signals received. Turn up from 0 to turn the unit on (LED will glow when unit is on). Slowly increase the gain until desired component is just being heard through the headset (normally between 0 and 1). The user may need to increase sensitivity to detect faint ultrasounds.



Note: The potentiometer works much like a squelch control on a CB. If turned up too high, the unit will be filled with “white” noise and limit the effectiveness of the UL101.

- Gain Mode: Full/Half Gain Switch: Located on the right side of the receiver, the gain mode switch is used to control signal distortion. The full gain setting (down position) reduces signal distortion when high intensity ultrasound is received and is the most common setting. It allows the unit to focus on the ultrasound from the component under test. Always use the minimum necessary gain.
- Meter Switch: The Meter response can be changed from Signal display when in the Up position and Battery state in the down position. When displaying battery level a full battery will register three ticks above the 5/10 mark of the meter.

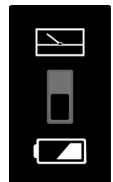

CTRL UL101 Key Components *continued*

Solid Probe Set

- Selectable length solid metal probes with self-threaded plastic base.
- Designed for contact mode to provide increased sensitivity, better clarity, and a better reduction of competing noise.
- Eliminate airborne ultrasound, detecting only the vibration of the component being tested. (A gas leak can produce ultrasound a hundred times more intense in air than a bearing or gearbox, so it is advantageous to focus on specific components).
- Recommended for inspection of mechanical components such as a gearbox, valve, bearing, or valve seat. Can also be used to inspect internal fluidic systems such as internal hydraulics for cavitation, leakage, and blockage.
- Includes 3", 5", 8" and 13" probes. Each length is designed for reach in different situations, while maintaining performance (It is best to use the shortest probe possible because ultrasound attenuates very quickly, unlike audible vibration).



Acoustic Probe Set

- Designed for inspection in difficult conditions such as hard-to-reach areas or for working around electrical components.
- The acoustic probes improve the ability to locate the source of the ultrasound signal by narrowing the area of the field of reception.
- Includes: two 12" hollow aluminum probes threaded at each end; one single-threaded 12" hollow aluminum probe; one single-threaded 12" hollow polycarbonate (non-metallic) probe for electrical applications; and an adaptor.
- Each of the probes can be connected together to provide an additional reach of three feet.



To reduce the chance of sustaining a shock or damaging equipment, always use non-metallic Polycarbonate Acoustic Extension Probe when working near electrical equipment.

CTRL UL101 Set-up Procedure

There are several items in your tool kit. Each item, if used properly, can be an important accessory for diagnosing your equipment.

UL101 Receiver

1. Remove the UL101 Receiver from the Carrying Case. Serial numbers are located at the bottom. If you have an intrinsically safe UL101, the serial number will begin RA3, which means your device was manufactured according to intrinsically safe standards and can be used in hazardous environments.
2. Remove the End Cap by turning the End Cap Screw counter clockwise 1.5 – 2 rotations.
3. Insert a 9-v alkaline battery. Check the decal inside the housing for correct installation. Do not push the battery or you may bend the contacts.



Always change Receiver and Transmitter batteries in a non-hazardous area. When inspecting in a potentially explosive environment, the Intrinsically Safe model of the CTRL UL101 should be used.

4. Replace the End Cap. Refer to Page 17 for instructions.
5. Push the headset jack firmly into the Receiver. There are two types of headsets including Over-The-Head (OTH) and Behind-The-Head (BTH), for use with hardhats. If you have a behind-the-head headset, make sure the plastic portion goes to the back of your head and the strap goes over top.
6. Turn on the Receiver using the Potentiometer (Power Supply On-Off Switch/Gain Control Knob). The LED should glow green.
7. Put on the headset. Turn the Output Switch to the Headset and Meter position and start with the Gain Mode Switch set to full gain. Rub your fingers in front of the microphone to create friction. Slowly increase the Potentiometer from 0 to reach the minimum setting (usually between 0 and 1) required to hear the converted ultrasound through the headset and see the meter move. If the signal is too strong, switch the Gain Mode Switch to half gain.
8. Attach the appropriate probe to the Receiver for the current application.

Typical Applications

Mechanical Systems

- Roller, Ball, Pillow Block and Other Bearings
- Trunion & Wheel Bearings
- Gears & Gearboxes
- Butterfly and Other Valves
- Pumps
- Motors & Engines
- Transmissions & PTO's
- Belts/Chains/Pulleys

Electrical Systems

- Electric Motor
- Bearings/Bushings/Brushes
- Ignition Systems & Alternators
- Switches, Coils, Spark Plugs & Wiring
- High Voltage Insulators
- Corona Discharges
- Transformers/Relay & Power Boxes

Hydraulic & Pneumatic Systems

- Cylinder Head Gaskets
- Check & Control Valves
- Actuator & Stop Valves
- Pumps & Valves
- Fittings & Hoses
- Bearings
- Internal Valve Leaks

Pressure & Vacuum Systems

- Compressed Air & Gas Leaks
- Cooling System Leaks
- Exhaust & Intake Manifold Leaks
- Steam Traps
- Condensers
- Refrigeration & Heating Systems
- Vacuum Leaks
- Pumps & Valves
- Fittings & Hoses
- Piping & Lines

Non-Pressurized Vessels

- Storage Tanks
- Pipes
- Door & Window Gaskets
- Bulkhead & Hatch Seals
- Windshields & Weather Stripping
- Clean Rooms
- Railroad Cars & Truck Bodies

Operating Techniques

There are two techniques used to inspect, test and diagnose with ultrasonic technology:

Scan Mode

Used in scan mode with one of the Acoustic Probes, Concentrators, or the One-Inch Acoustic Probe attachment, the UL101 enables the user to detect and pinpoint problems such as air, steam, gas, and vacuum leaks; leaks in exhaust systems, exchangers, and A/C systems; and electrical arcing or discharge. In addition, when used in conjunction with the UT2000, defects in seals and gaskets of non-pressurized vessels or cavities can be detected and pinpointed.

The user aims the Receiver, moving it side to side, up and down to locate the strongest (most intense) ultrasound signal, following the ultrasound to its source. In order to pinpoint the location of the leak, it is helpful for the user to reduce the sensitivity of the Receiver by adjusting the Potentiometer down as he/she gets closer to the source of ultrasound.

Contact Mode

Used with a Solid Probe attachment, the UL101 allows the user to distinguish the ultrasound generated by individual components. This mode is used to determine the operating condition of an internal component such as bearings, gears, valves, solenoid valves, cylinders, actuators, etc. By distinguishing the ultrasound of individual components, the user is able to determine changes in the operating condition of those components very early in the failure process.

The user places the tip of the solid probe on a housing nearest the component, such as a bearing or gear, under test. The user will start with the Gain Mode in full gain and will slowly increase the Potentiometer from 0 until converted ultrasound of the component under test becomes audible. (This setting is normally somewhere between 0 and 1.) If the signal is too strong, adjust the Gain Mode to half gain.

CTRL UL101 Set-up Procedure *continued*

UT2000 Universal Transmitter

1. Remove End Cap. Turn End Cap Screw counter clockwise 1.5 – 2 rotations.
2. Insert 9-volt battery. Check decal inside housing for correct installation.



Always change Receiver and Transmitter batteries in a non-hazardous area. When inspecting in a potentially explosive environment, the Intrinsically Safe model of the CTRL UL101 should be used.

3. Replace End Cap. Refer to Page 17 for instructions.
4. Push the On/Off Switch toward the LED to turn the Transmitter "ON". The LED should glow green.

Operating & Technical Tips

- Use the UL101 on a daily basis for a wide variety of inspection, testing and diagnostic applications. It will cut your troubleshooting time and often detect defect conditions when they are just starting, before damage occurs.
- When beginning to use the CTRL UL101, listen to components often in order to naturally develop a sense of how normal operation sounds. When the user recognizes normal, abnormal will stand out.
- Keep operating conditions and UL101 Receiver settings the same each time you test a piece of equipment. Any noticeable change can be attributed solely to the change in the equipment's condition.
- Always start with the Gain Mode set to full gain, and only switch to half gain when necessary.
- Don't turn the Potentiometer too high for testing. Start with the Knob at 0 and slowly increase the setting to reach the minimum setting required to hear the converted ultrasound through the headset and see the meter move.
- Reduce sensitivity of Receiver to minimum if there is a need to aim the Receiver directly at the Transmitter from short distances. This avoids discomforting sound.
- To prolong battery life, both the Receiver and Transmitter should be shut off when not in use. Batteries should be removed if not used for extended periods.
- When auditing a compressed air, gas or steam system or an electrical system, start near the power source and scan along the system. Keep the receiver within several inches of system lines and components for best results.
- When using the Transmitter, make sure that the opening into which it is placed is closed to prevent the escape of ultrasonic waves that could be misleading.
- The One-Inch Acoustic Probe or the Acoustic Extension Probes can be attached to the Transmitter to inject ultrasound into a non-pressurized vessel or cavity. To reduce the intensity of ultrasound being received, the user can attach a 3/8" diameter plastic hose (flexible or rigid) to the one-inch acoustic probe. The flexible hose may also be used in crowded areas (such as under the hood of a car) to gain access to a component.
- Call CTRL Product Support for assistance when problems arise.

Safety Tips

Users of the UL101 must be properly trained on and follow all safety requirements and standards when working in the area of equipment under test.

DANGER



To avoid possible death or serious injury from electric shock:

Never touch the UL101 or its attachments to electrical equipment or its components unless they are properly grounded.

Always use the non-metallic Polycarbonate Acoustic Probe, which has high electrical resistance, when searching for airborne ultrasound near high voltage equipment.

WARNING



To avoid possible entanglement hazard:

Never touch moving components with the UL101 or its attachments.

WARNING



Always change Receiver and Transmitter batteries in a non-hazardous area.

When inspecting in a potentially explosive environment, the Intrinsically Safe model of the CTRL UL101 should be used.

WARNING



Power Supply: 9 volt Alkaline Battery such as DURACELL - Procell #PC 1604-9V, Eveready, Energizer, or equivalent. Ensure battery is inserted properly for normal operation.

GENERAL INFORMATION

Maintenance and Care

- The UL101 tool requires no special maintenance or calibration.
- The UL101 should be cared for as any high quality electronic tool. Wipe clean as necessary and check for proper operation as described in the Set-Up Procedure.
- It is recommended that the UL101 Receiver Jacket (sold separately) be used to help protect the Receiver from everyday wear and tear, and any accidental misuse.
- Do not immerse the Receiver or Universal Transmitter in liquid.
- Use only alkaline batteries. Batteries should be removed if not used for extended periods.
- Use only a Headset with impedance of 600 Ohms +/- 15%. It is strongly recommended that the UL101 be used only with the Headset provided by CTRL Systems.
- For repair services call CTRL Systems, Inc. at 877-287-5797.

Expected Battery Life

The CTRL UL101 Receiver and UT2000 Transmitter are both powered by a 9-volt alkaline battery. A single battery can power the UL101 for approximately 45 hours of continuous use. With typical use of the UL101, the life of the battery is approximately 5 months. A single fresh battery can power the UT2000 for up to 300 hours of continuous use.

Determining if Batteries Need to be Changed

The meter output on the UL101 Receiver becomes a battery power indicator by turning the output switch to the down position where only the headphones are pictured. The battery will need to be replaced if the needle drops below the "5-10" mark on the meter.

The battery for the Transmitter should be replaced once the LED does not light up.

Adverse Operating Conditions

When using the UL101 ultrasound diagnostic tool, the user may have to perform testing in adverse operating conditions. The following are techniques that minimize the effect of these conditions.

Too much competing ambient noise:

Too much competing ambient noise may result in difficulty hearing the individual component under test.

Solutions:

1. If feasible, change the testing environment by moving or shutting down the competing system.
2. Use InCTRL Mobile in conjunction with the UL101 to capture the signal from the component. Play the sound back later in a quiet environment.

Too much competing ultrasound:

Too much competing ultrasound may result in difficulty hearing and discriminating the signal from the individual component under test.

Solutions:

1. Turn the Gain Mode Switch to half gain.
2. Turn the Potentiometer to a lower setting.
3. Shield the component under test from other sources of ultrasound with a piece of cardboard, clipboard, etc. If possible, inspect the component under test with your back to the competing system.
4. If feasible, change the testing environment by moving or shutting down the competing system.

Reflection:

When following ultrasound leads to an unlikely source, such as a wall, the ultrasound may have traveled to the wall and reflected off of it.

Solutions:

Turn your body around 180° and then scan again for the most intense ultrasound. Follow the most intense ultrasound to its source. If the source of ultrasound is very strong, multiple reflections may occur.

* InCTRL is sold separately from the CTRL UL101. For more information call CTRL Systems (1.410.876.5676) or visit the CTRL website (www.ctrlsys.com)

Replacing Batteries

1. Remove the End Cap by turning the End Cap Screw counter clockwise 1.5 - 2 rotations.
2. Remove the old 9-volt battery.
3. Insert the new 9-volt battery, making sure the +/- terminals are facing the proper direction. Check the decal inside the housing for correct installation. Do not push the battery or you will bend the contacts.



Always change Receiver and Transmitter batteries in a non-hazardous area. When inspecting in a potentially explosive environment, the Intrinsically Safe model of the CTRL UL101 should be used.

Use only a 9-volt Alkaline Battery such as DURACELL-Procell # PC1604-9V, Everready, Energizer, or equivalent. Always follow instruction on the battery package when handling batteries.

4. Replace the End Cap by pressing the Cap firmly into the end of the Receiver until it makes contact with the aluminum housing, then firmly turning the End Cap Screw Clockwise until tightened. This will supply the correct tension to the battery contacts.

Warranty & Repairs

Components of the CTRL UL101 Kit have a five-year warranty against defects in workmanship and materials (excluding batteries). Any defective item that is returned within this time showing signs of abuse, tampering, neglect or misuse will be repaired at normal time and material costs.

An RMA # (Returned Merchandise Authorization Number) must be obtained for both warranty and contract service repairs. Contact the service department by phone: **1.410.876.5676** or **1.877.287.5797** (toll free US and Canada), or by e-mail: **warranty@ctrlsys.com**.

Level I and Level II Certified Ultrasound Operator Training

Level 1 Training is a 4½-day session (36 hours) written in accordance with ASNT Recommended Practice No. SNT-TC-1A and based upon the body of knowledge contained in ISO Standard 18436-8:2013 (E). Participants will learn basic principles of ultrasound and A&SB (airborne and structure-borne) ultrasonic detection; use and operation of ULDs (ultrasound listening devices); an introduction to the various disciplines for the technology; and how to execute a condition-based monitoring (CBM) program. This program is classroom-intensive, with hands-on elements. The course culminates in a written examination. Successful completion of the course will certify the participant as a Level I Ultrasound Operator.

Level II Training is a 2-day training session (14 hours) specific to one of four individual disciplines (Electrical, Steam, CBM/Lubrication, Air). This program is classroom intensive, with hands-on elements. Each of these courses culminates in a written examination. Successful completion of an individual course will certify the participant as a Level II Technician in that specific discipline. Successful completion of all four discipline-specific courses will certify the participant as a Level II Ultrasound Operator.

Level I and Level II courses are available at specific training locations throughout the year (see the training calendar at www.ctrlsys.com/training to register). Both courses can also be conducted on-site at your facility.

For more information, please call +1 (410) 876.5676 or contact CTRL Systems by email at training@ctrlsys.com.

CTRL Systems Learning Library

CTRL Systems is curating an online library of PDF documents related to specific disciplines and applications for the UL101 and InCTRL. White papers can be located online at www.ctrlsys.com/whitepapers.

Sound Solutions are 1-2 pages of detailed, step-by-step instructions for a single application within a specific industry. Our Sound Solution Library can be located online at www.ctrlsys.com/soundsolutions.

For more information, please call +1 (410) 876.5676 or contact CTRL Systems by email at info@ctrlsys.com.

ADDITIONAL RESOURCES



InCTRL Condition-Based Monitoring (CBM) SaaS

InCTRL is a web-based SaaS (software as a service) for ultrasound trending, reporting and call-to-action. InCTRL allows maintenance technicians to track and analyze ultrasound readings on critical assets and provides email alerts when thresholds are met or exceeded. It is a low-cost, low-risk condition-based monitoring (CBM) solution.

Benefits

- Uses waveform data samples collected with the InCTRL Mobile app and the CTRL UL101.
- Organizes and simplifies data collection, allowing users organize test points by location and inspection route.
- Allows users to easily access test point history and compare samples over time.
- Trends ultrasound test data with graphs, reports and health assessments.
- Flags suspect equipment, compiling flagged assets into reports.
- Automatically sends email notifications when flagged components exceed established thresholds.
- 24/7 database access from any tablet or computer.
- Comprehensive condition-based monitoring (CBM) solution for large facilities and organizations.

Technical Support

- Product Specialists are available via phone or e-mail during normal business hours (Monday through Friday, 9:00am through 5:00pm EST) to assist with technical and application questions regarding product use. Call 877-287-5797.
- CTRL's R&D Team is available to provide solutions to unique applications and challenges. These services can be coordinated through a Product Specialist or Account Manager.

Training CD

Enclosed with the CTRL UL101 Kit is a Training CD that introduces the technology and provides helpful set-up and testing procedures, and includes sound and motion demonstrations of the UL101 in use. We recommend you take 30-45 minutes to review the CD.

On-site Training

Quick Start Training is a half-day session (4 hours) at your facility or at CTRL headquarters in Westminster, Maryland, USA. Trainees will learn basic principles of ultrasound; use and operation of the UL101; and airborne ultrasound detection strategies tailored to your organization and specific needs.

Condition-Based Monitoring (CBM) Training & Integration is a 1½-day training session at your facility (12 hours). This program is a combination of classroom and hands-on training. Up to 12 trainees will learn the fundamentals of using ultrasound technologies for predictive maintenance; learn basic operation of the UL101, and InCTRL. The hands-on portion also incorporates the use of the UL101, InCTRL, and InCTRL Mobile.

Customized Training is available for multi-site implementation or application specific training. Daily, weekly, and contract rates are available.

For more information, please call +1 (410) 876.5676 or contact CTRL Systems by email at training@ctrlsys.com.

Condition-Based Monitoring Products *continued*

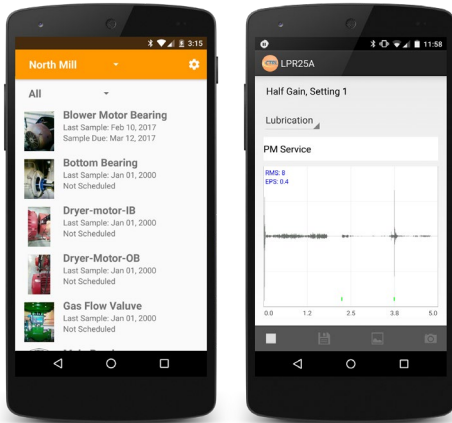

InCTRL Mobile

Using the UL101 and InCTRL Mobile data collection mobile app, maintenance technicians can capture an audio/visual sample of the asset under test. Maintenance technicians can quickly make intelligent maintenance decisions about critical equipment while on the plant floor.

Benefits

- Captures 20-second ultrasound samples.
- User-friendly controls and menus, including photo capture, detailed instructions, and technician comments on every test point.
- Calculates Root Mean Square (RMS), creates a real-time waveform, and provides instantaneous health assessment of the asset under test. (i.e. Normal, Under-Lubricated, Questionable, Suspect)
- Automatic updates to the mobile app when new features or bug fixes are made available.
- Triggers instantaneous email warnings to critical personnel when a sample exceeds set thresholds.
- Integrates with CTRL's web-based database management SaaS, InCTRL, for a low-cost ultrasound condition-based monitoring solution.

Recommended Complimentary Products & Accessories**Accessories:**

Belt Pouch	P/N: 005035
Receiver Jacket.....	P/N: 005055
Gel Ear Seals	P/N: 005007
Defect Tags, Red	P/N: 030085
Defect Tags, Yellow	P/N: 030087
Y-Splitter	P/N: 005045

Recommended Complimentary Products:

InCTRL Initial 1-Year License	P/N: 041000
InCTRL Renewal 1-Year License.....	P/N: 041005
InCTRL Connection Cable	P/N: 008030
Android Mobile Phone for InCTRL Mobile (<i>U.S. Only</i>)	P/N: 008150
PowerBeam 300.....	P/N: 007005

Part Re-Ordering Information:

UL101 Receiver, Standard Model	P/N: 026005
UL101 Receiver, Intrinsically Safe Model	P/N: 026007
UT2000 Transmitter, Standard Model.....	P/N: 026010
UT2000 Transmitter, Intrinsically Safe Model	P/N: 026012
Headset (Over-the-Head).....	P/N: 025010
Headset (Behind-the-Head)	P/N: 025005
Large Concentrator	P/N: 070007
Mini-Concentrator	P/N: 070009
Acoustic Tip.....	P/N: 070037
3-inch Solid Probe	P/N: 040045
5-inch Solid Probe	P/N: 040050
8-inch Solid Probe	P/N: 040055
13-inch Solid Probe	P/N: 040060
23-inch Solid Probe	P/N: 040065
1-inch Acoustic Probe	P/N: 070035
Acoustic Extension Probe Adapter	P/N: 070005
Metal Acoustic Probe (threaded ends).....	P/N: 070045
Metal Acoustic Probe (single threaded end).....	P/N: 070050
Polycarbonate Acoustic Probe	P/N: 070040
Training CD	P/N: 005025
Operator's Manual.....	P/N: 005010

Corona Discharge and Electrical Arcing Detection / Long-Distance Listening Applications



PowerBeam 300

Using the UL101 with the PowerBeam 300 allows maintenance technicians to detect corona discharge and electrical arcing up to 300 feet away. The Power Beam also provides long-range detection for hazardous work environments. (UL101 and David Clark head set not included with PowerBeam 300.)

Benefits

- No calibration necessary.
- Uses two standard AAA batteries, no recharging.
- Narrow beam of reception allowing differentiation between various sources of ultrasound.
- Laser pointer and rifle sight for accurate pinpointing.