

Learn To Know...

The NO-ZONE



THE SHADED AREA SURROUNDING EACH VEHICLE REPRESENTS THE DANGER ZONE or “NO-ZONE” IN WHICH THE VEHICLE OPERATOR’S VIEW OF PEDESTRIAN TRAFFIC IS GREATLY REDUCED OR OBSCURED ALTOGETHER. NOTE THAT ALL DISTANCES ARE APPROXIMATE. SPECIFIC DISTANCES MAY VARY.

Eye level 10' 0" above
ground level

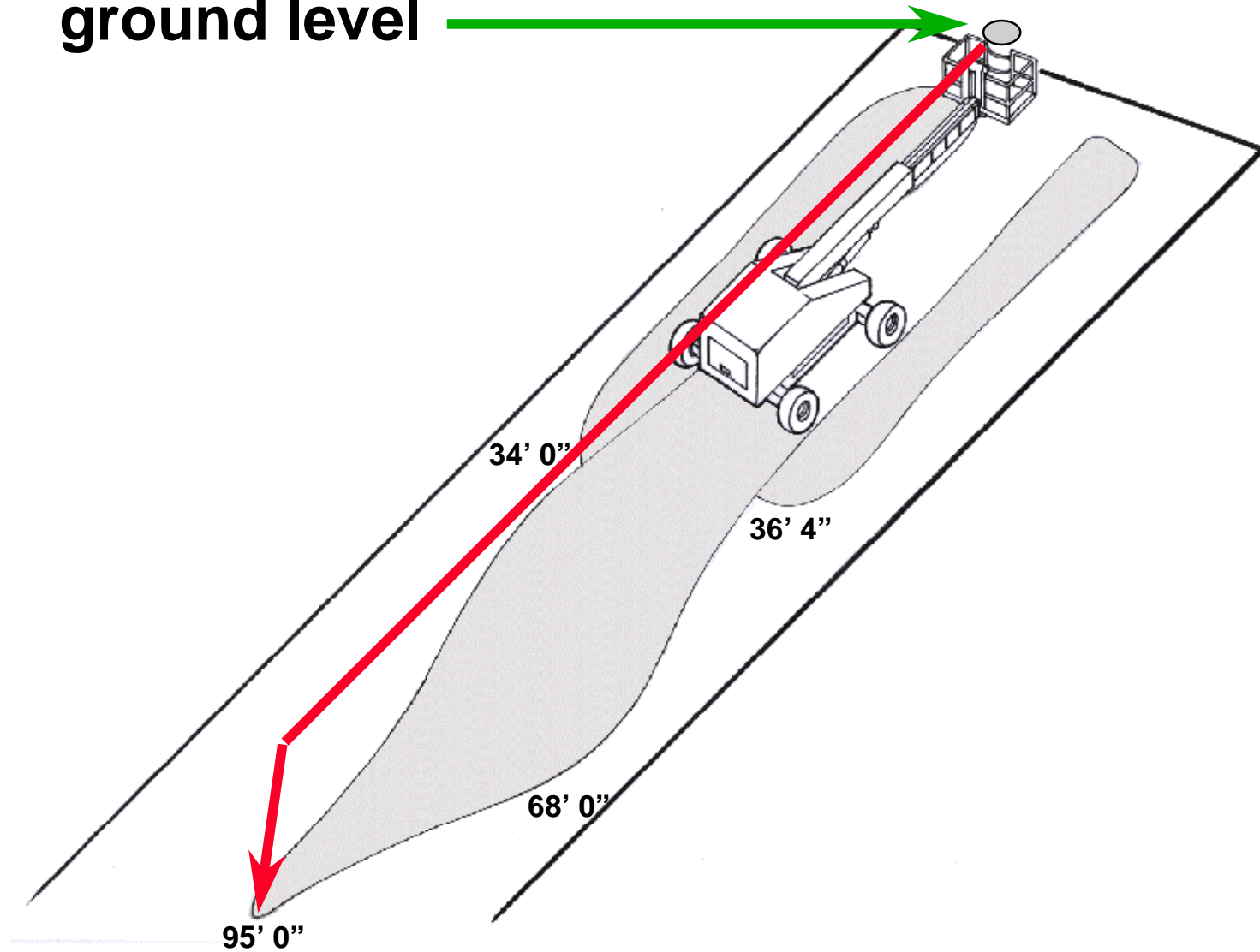

Manlift

Eye level 7' 0" in above ground level

Area of fully obstructed view

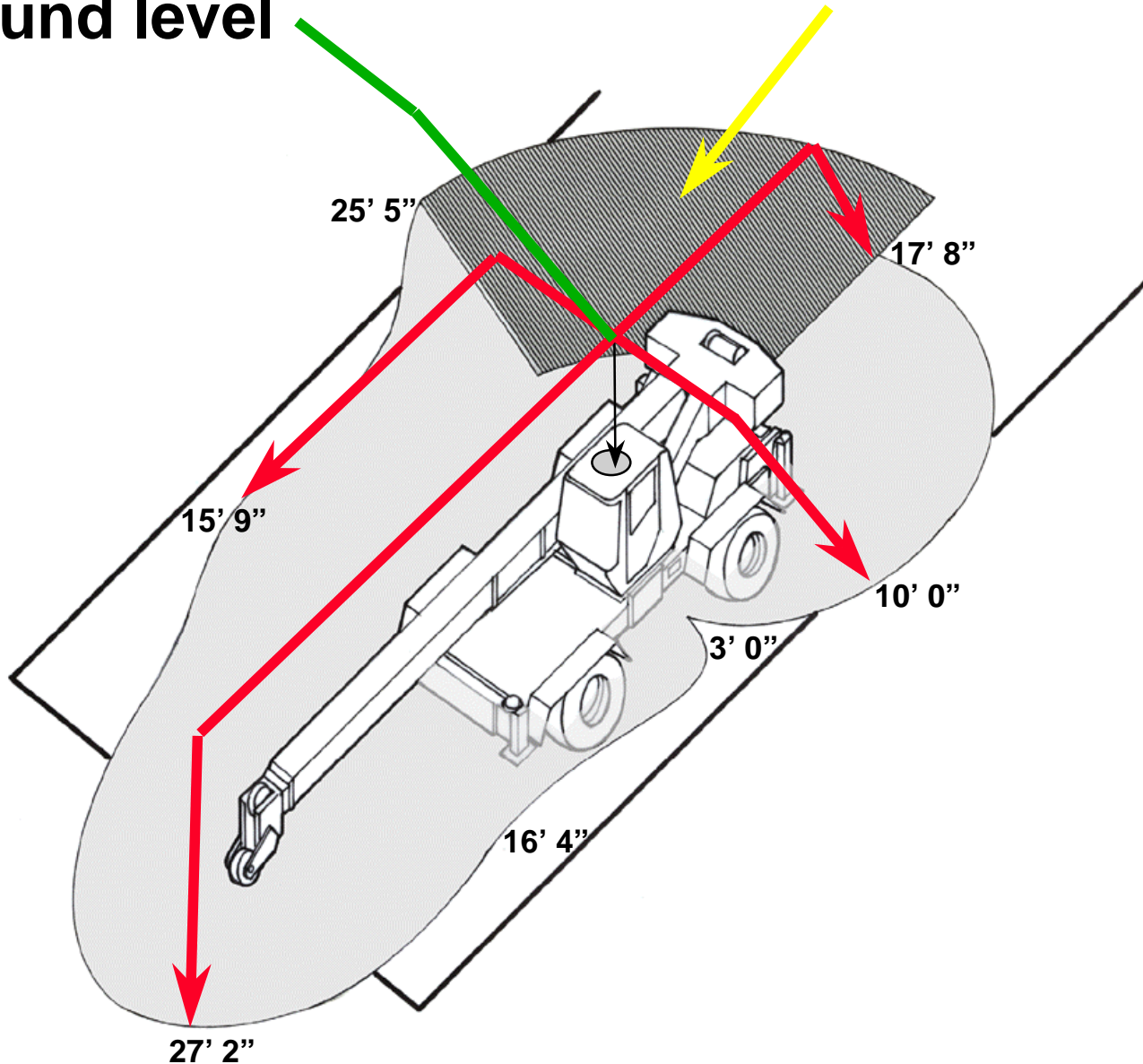

Hydraulic Crane

Eye level 17' 0"
above ground level

These measurements are
with the operator's cab
in lowest position

**Area of fully
obstructed view**

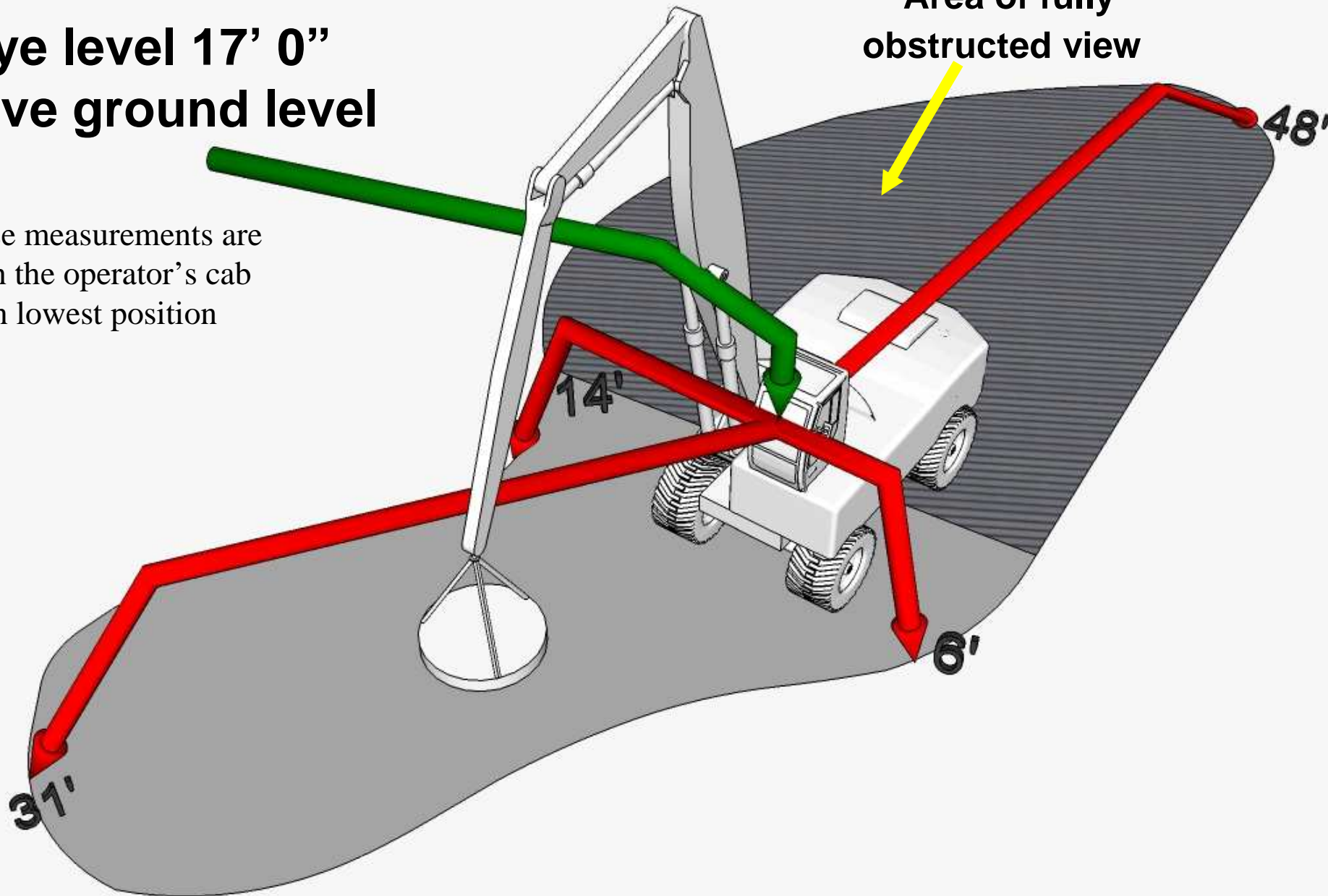

Material Handler

Wheeled Unit

Eye level 9' 6"
above ground level

Area of fully
obstructed view

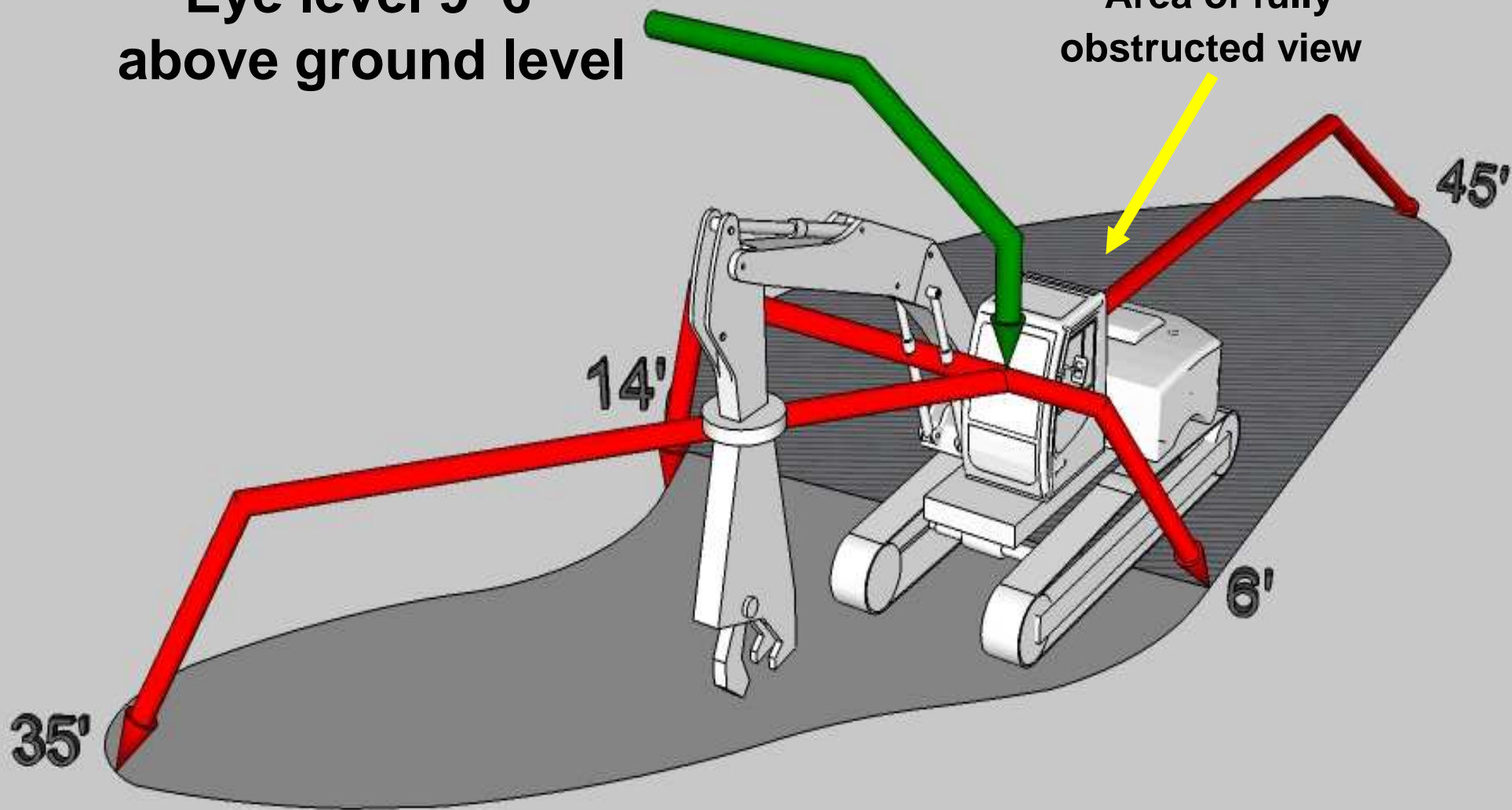

Mobile Shear

Eye level 17' 0"
above ground level

**Area of fully
obstructed view**

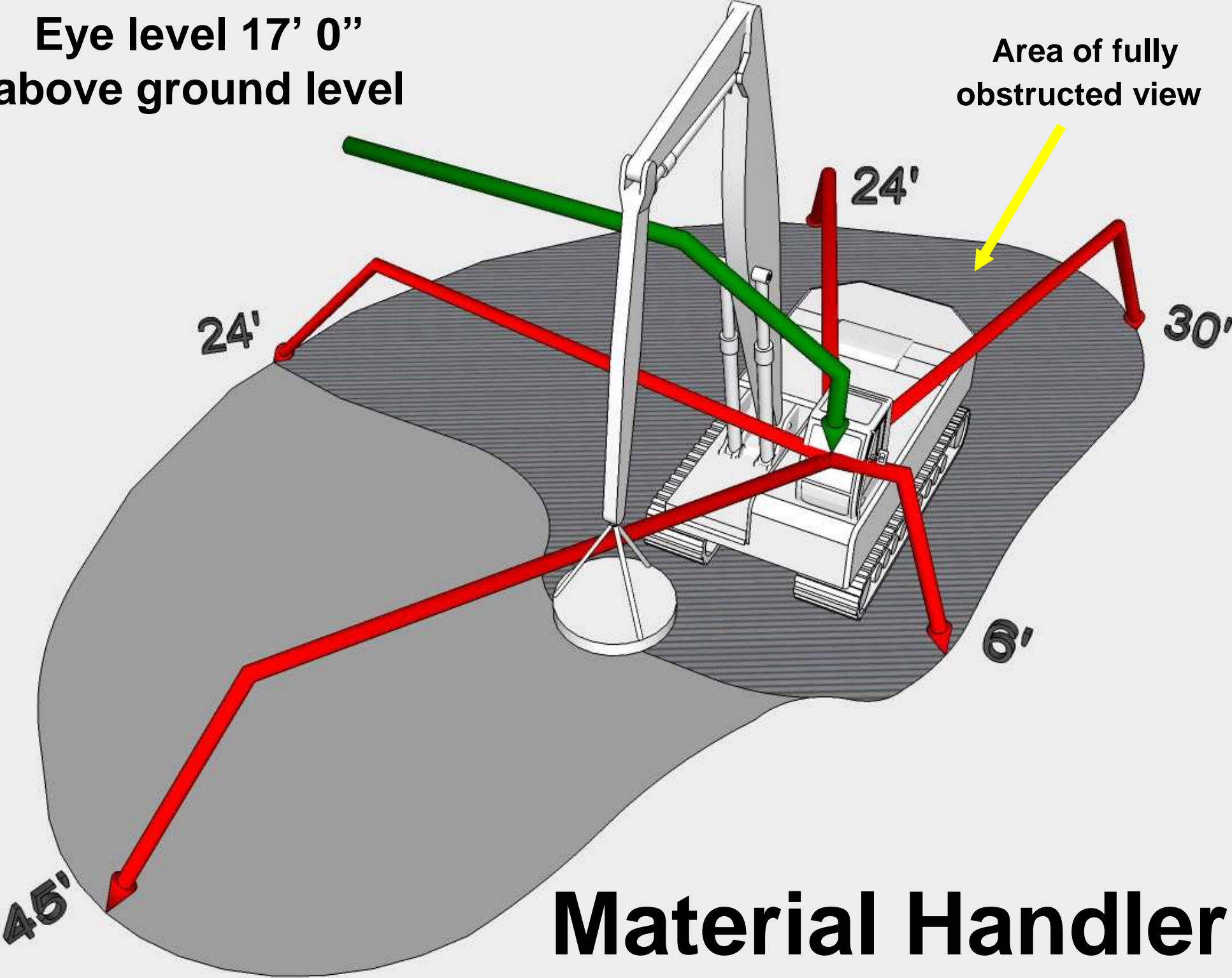

Material Handler

Eye level 7' 7" above ground level

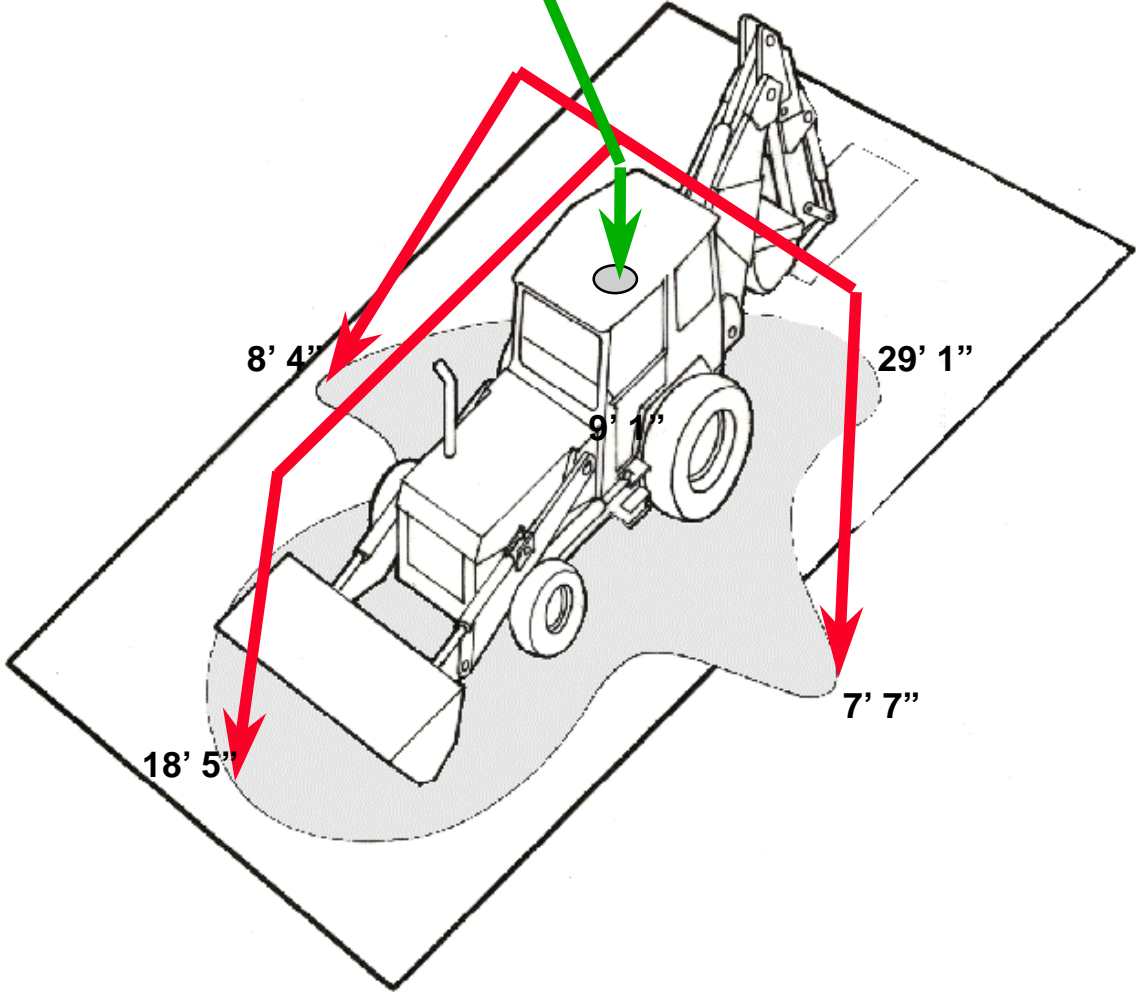

S-25 BACKHOE

Backhoe

Eye level 6' 3" above ground level

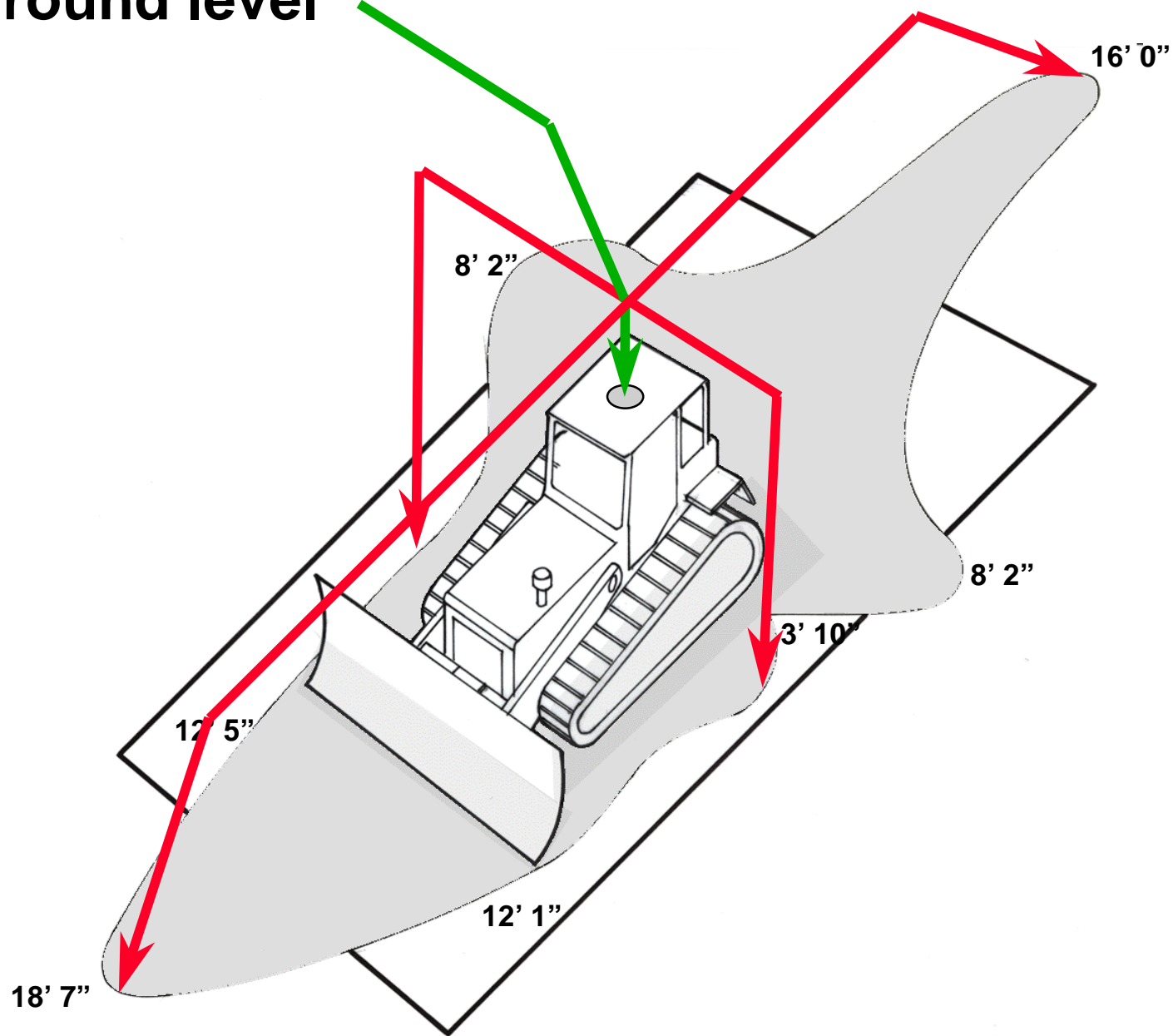

Bulldozer

Eye level 10' 0" above ground level

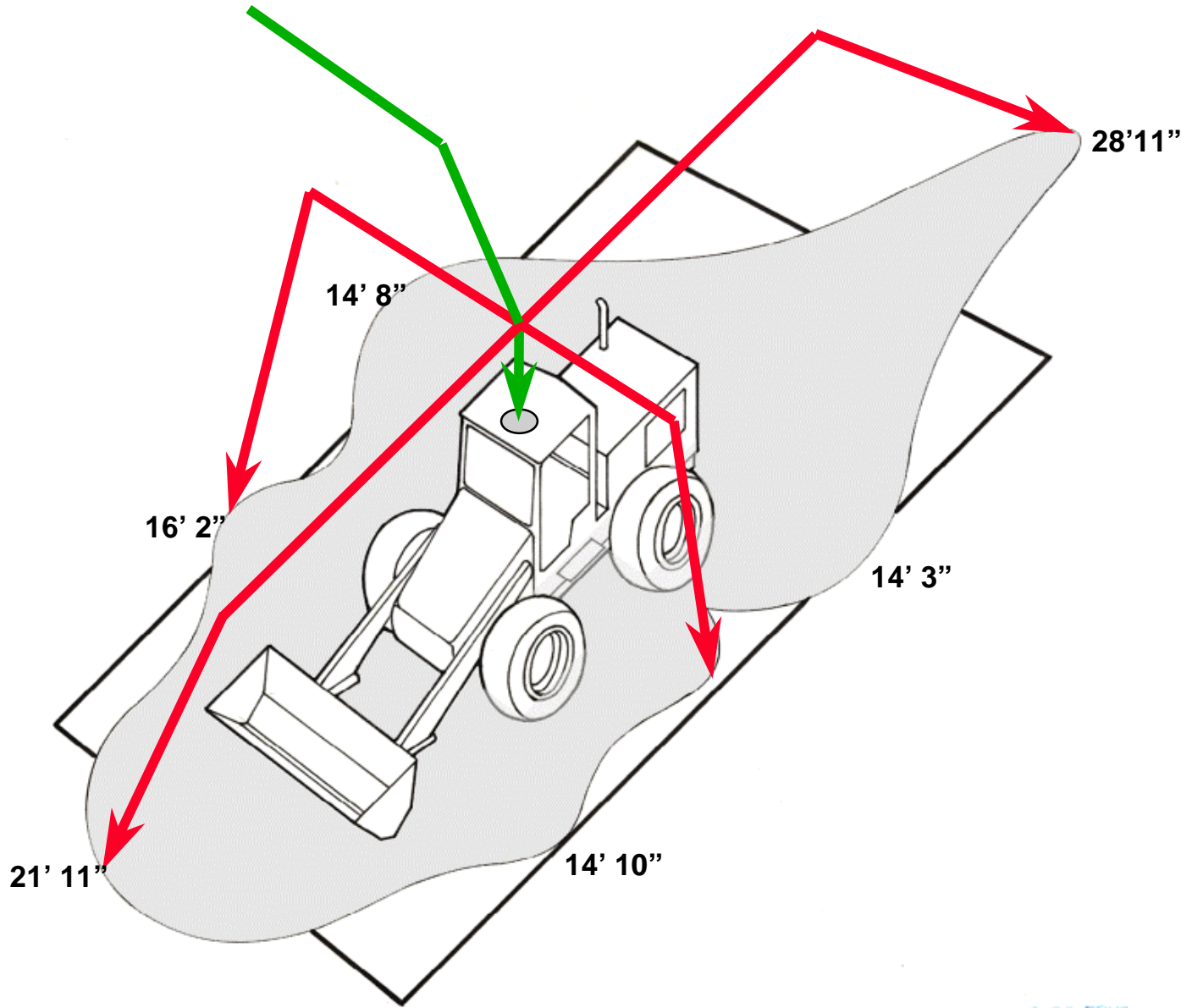

S-28 FRNT

Front End Loader

Eye level 5' 5" above ground level

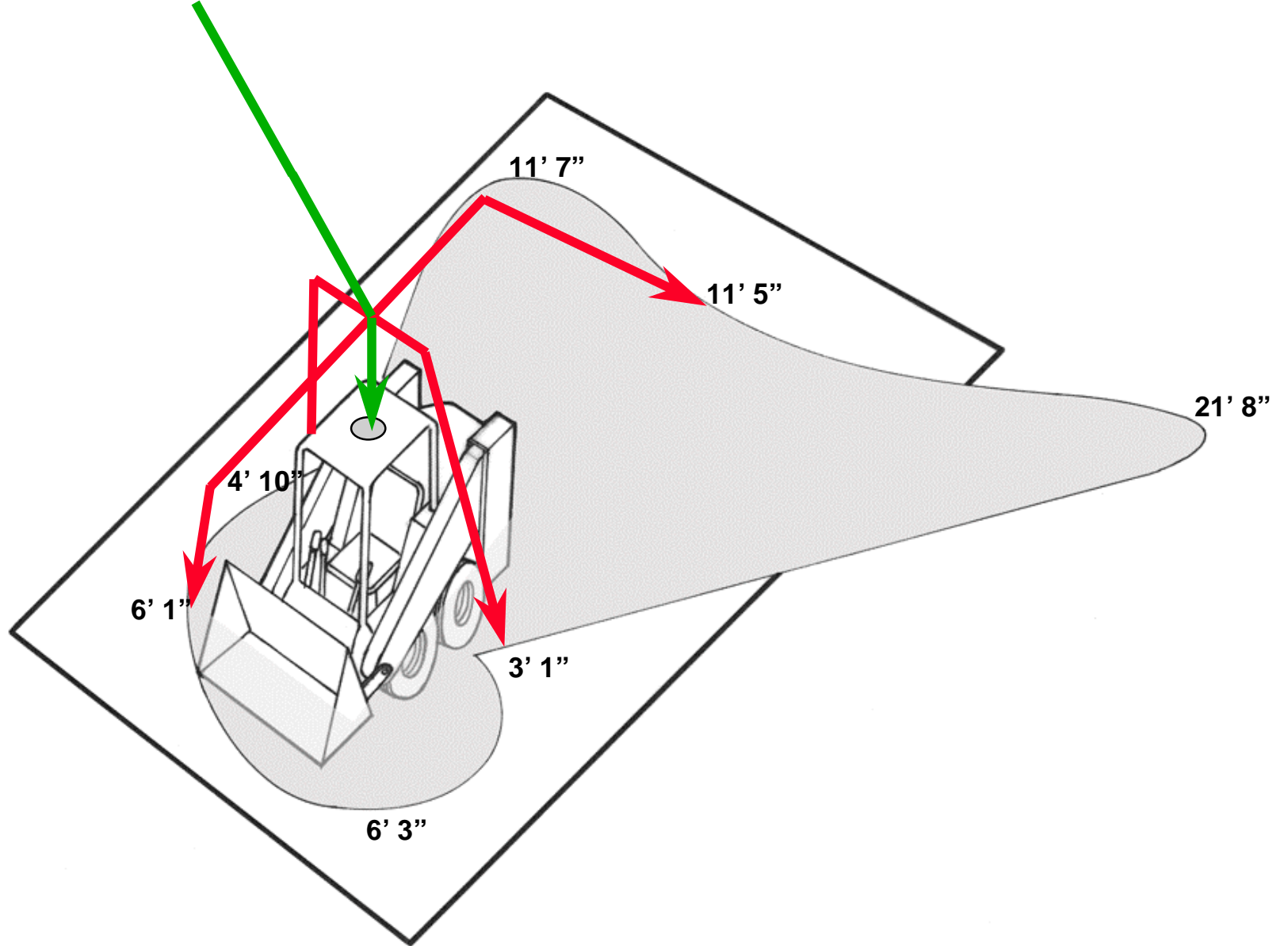

Skid Steer

Eye level 7' 3" above ground level

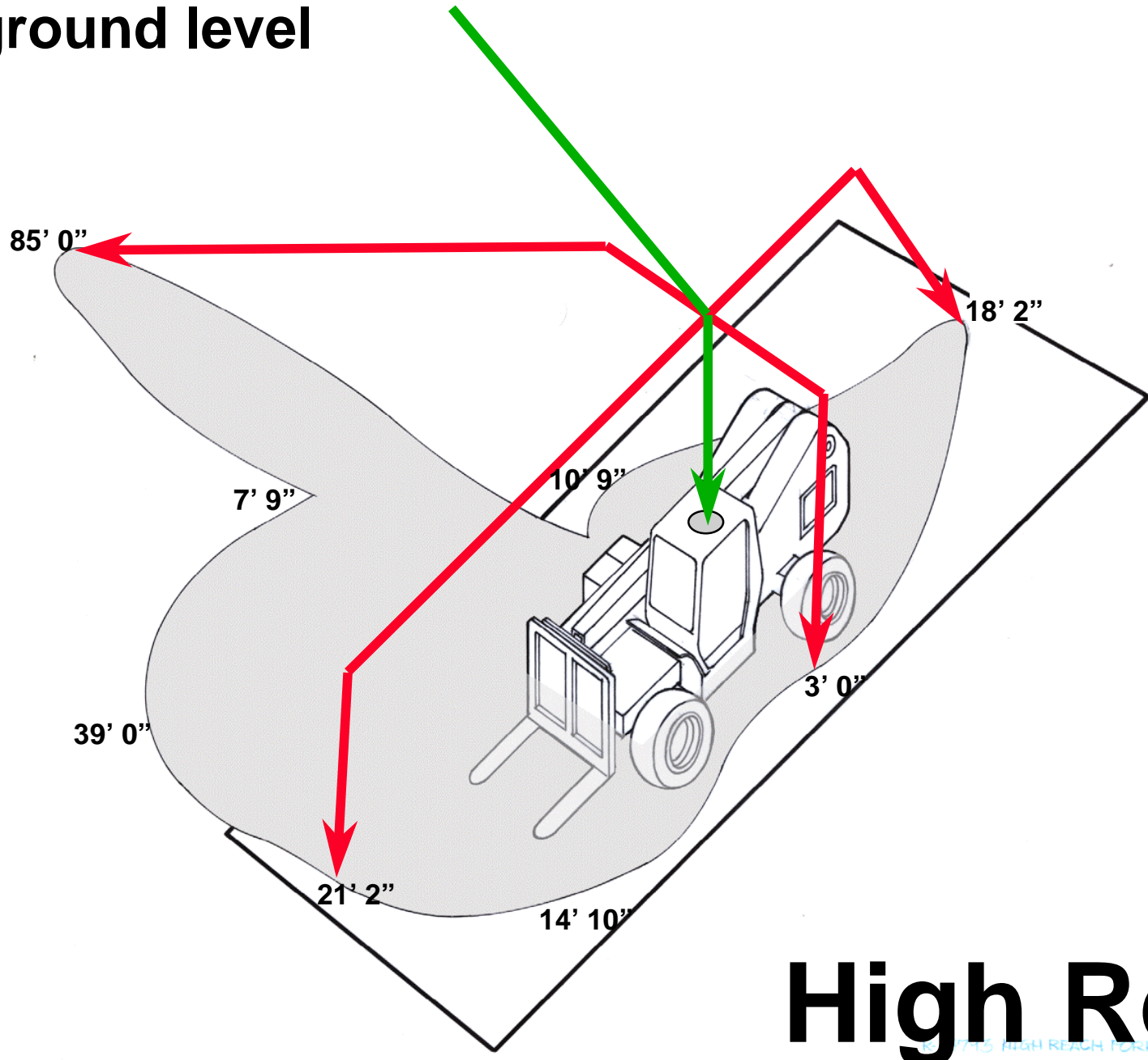

**High Reach
RT Fork Lift**

**Eye level 6' 0" above
ground level**

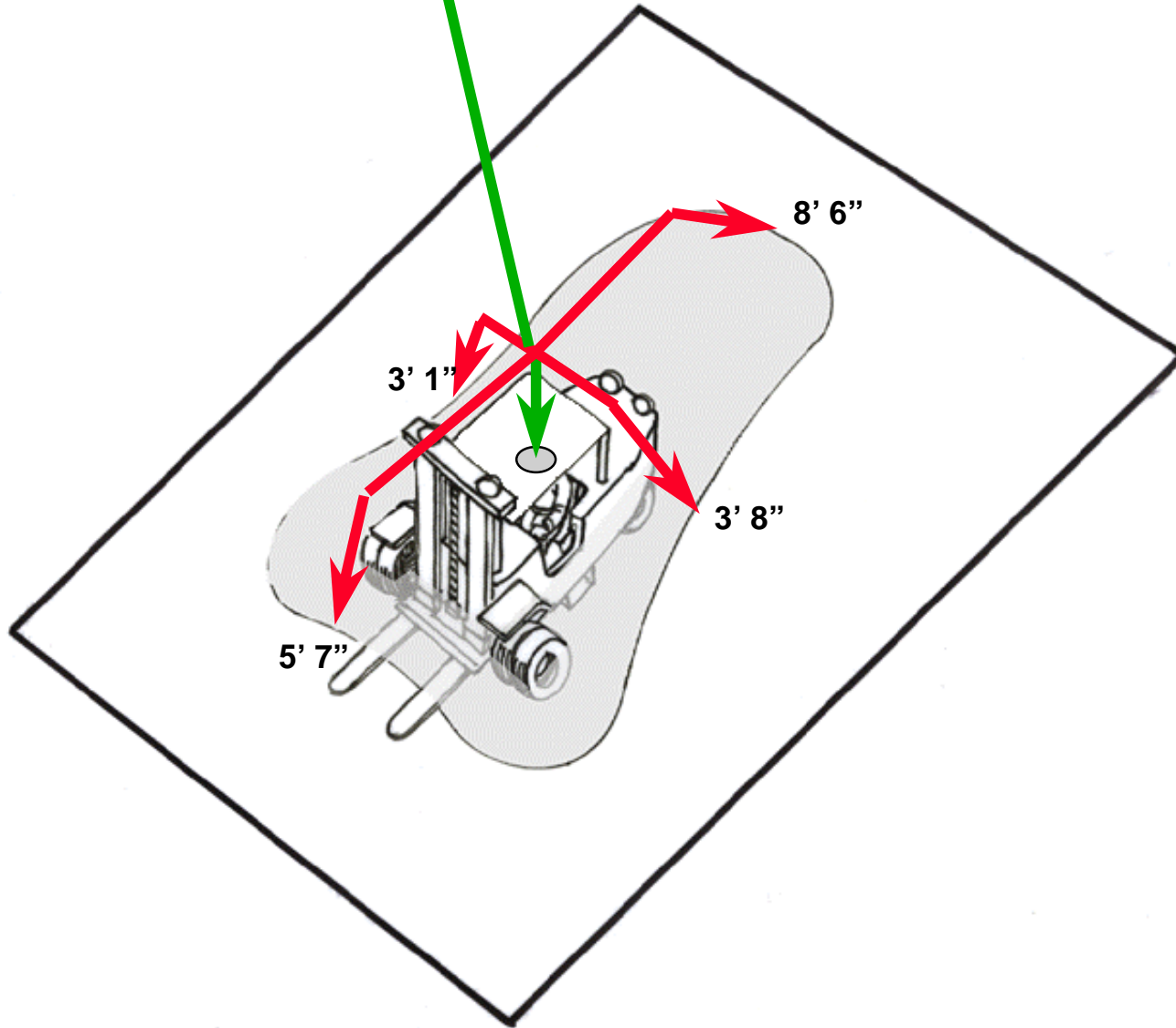

3 Ton Forklift

**Eye level 8' 8" above
ground level**

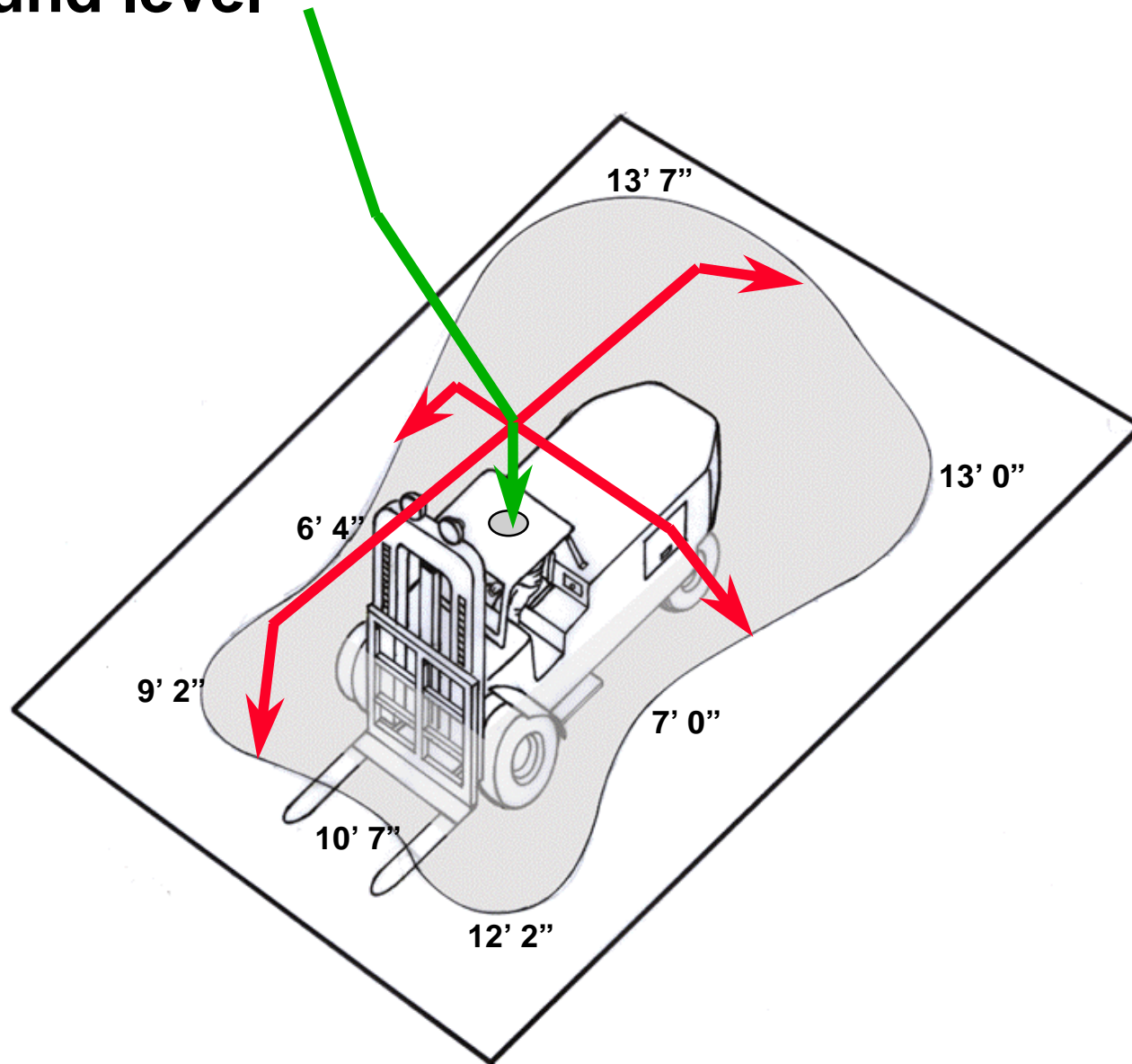

10 Ton Forklift

Eye level 8' 9" above ground level

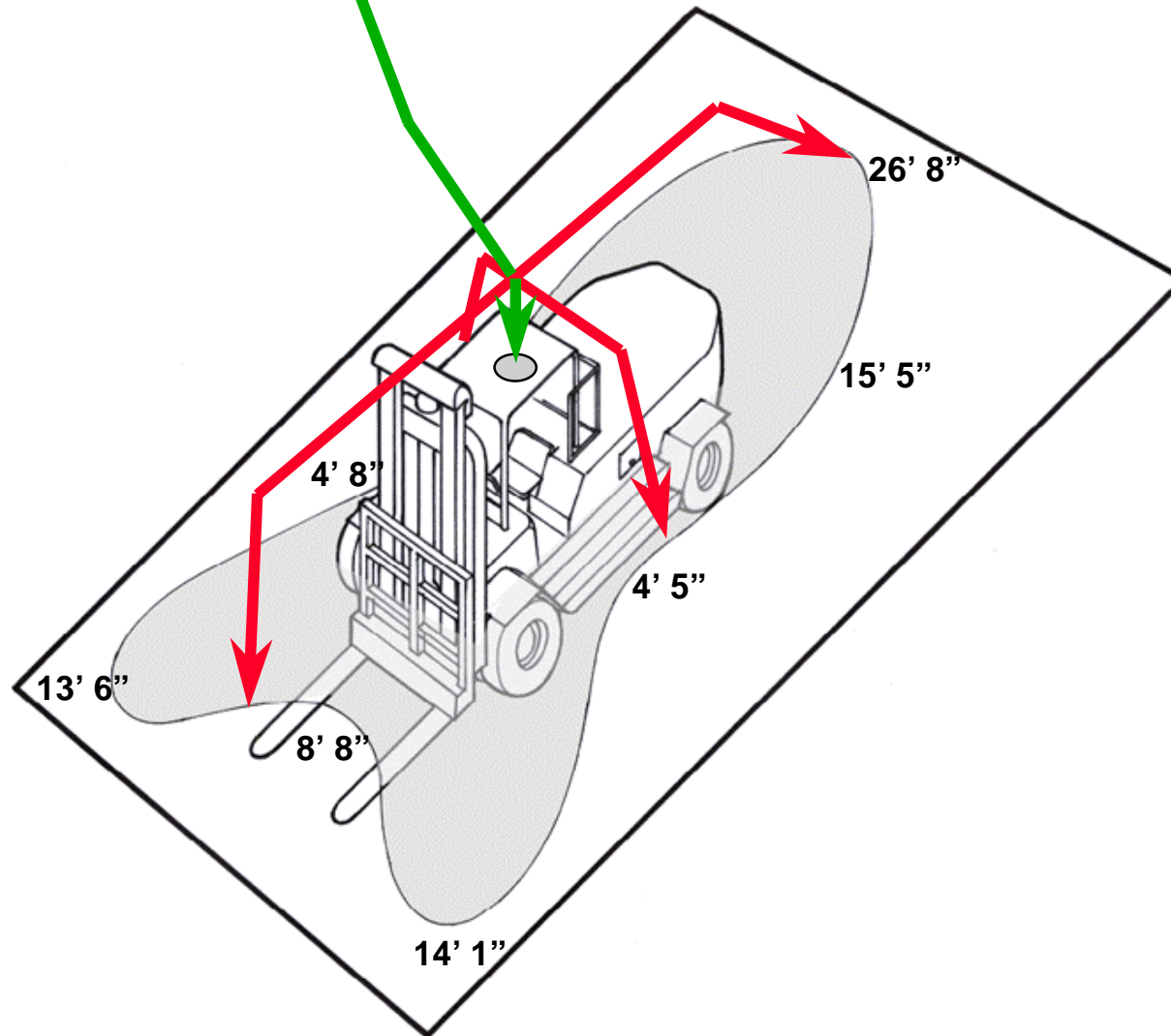

17 Ton Forklift

Eye level 6' 10" above ground level

Area of fully obstructed view

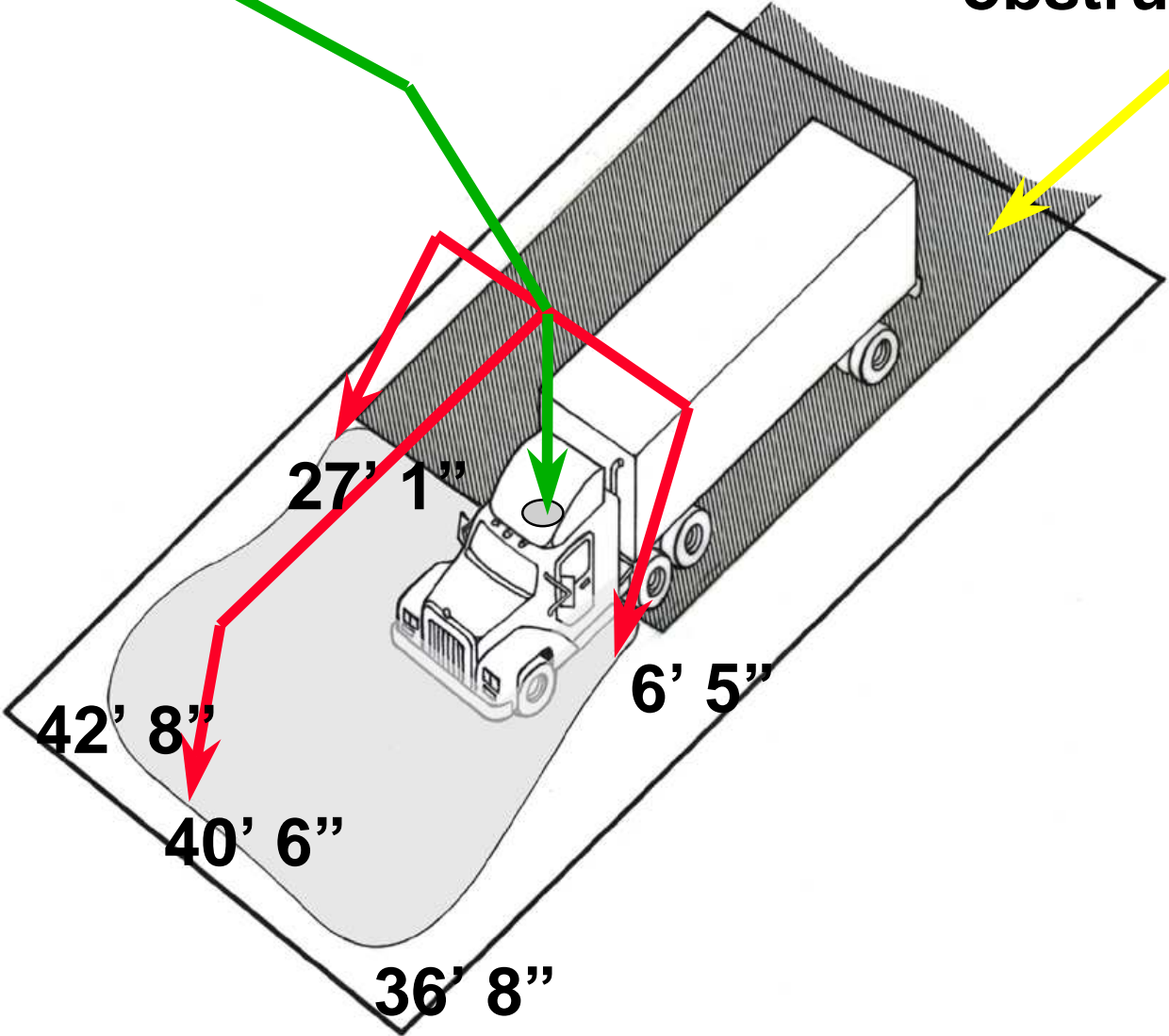

Semi-Truck & Trailer

Eye level 8' 0" above ground level

Area of fully obstructed view

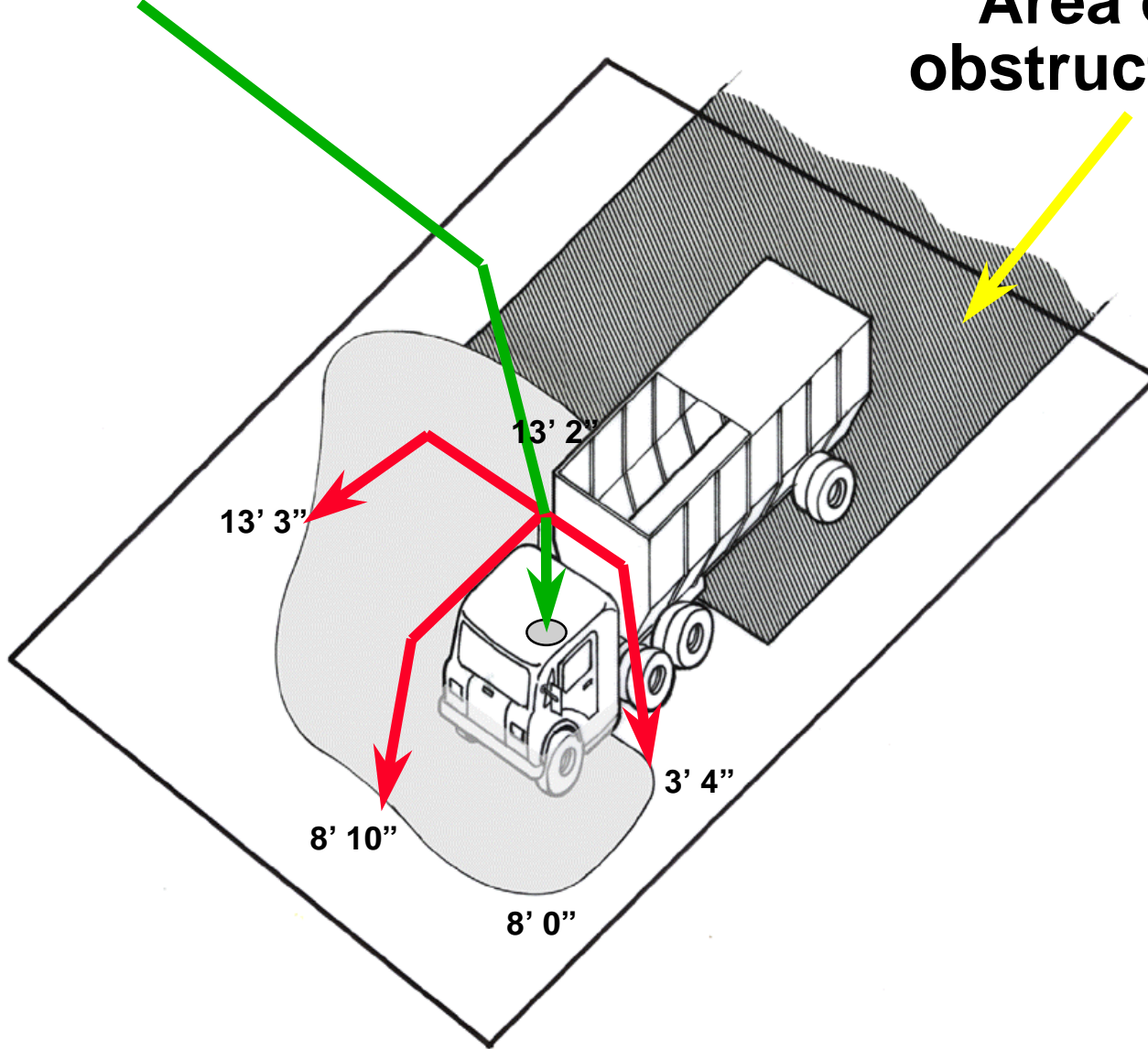

Refuse Truck

Eye level 8' 0" above ground level

Area of fully obstructed view (more than 300 ft)

Area of fully obstructed view from Eductor Hose (more than 100 ft)

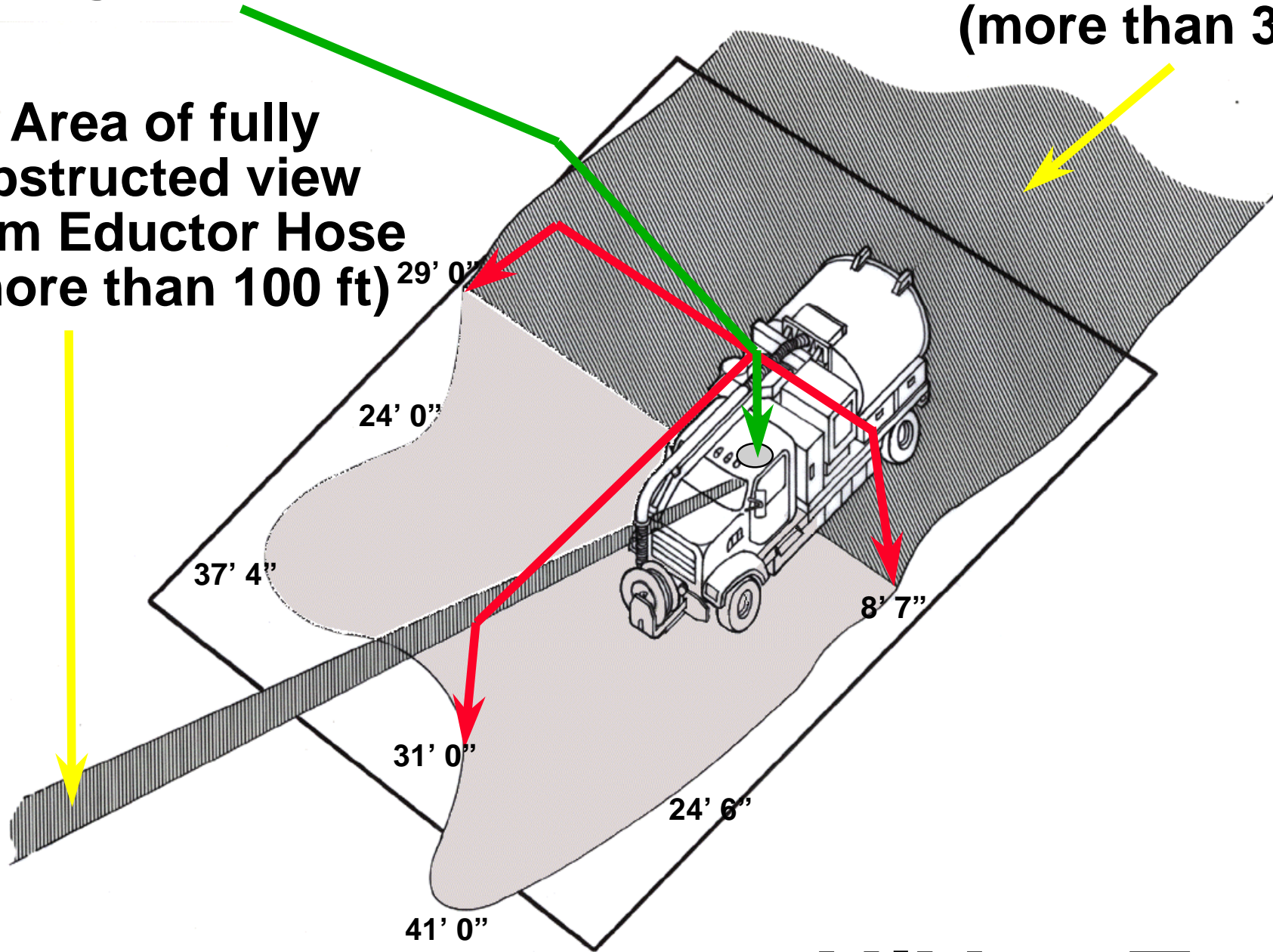

HiVac Truck

Eye level 7' 1" above ground level

Area of fully obstructed view

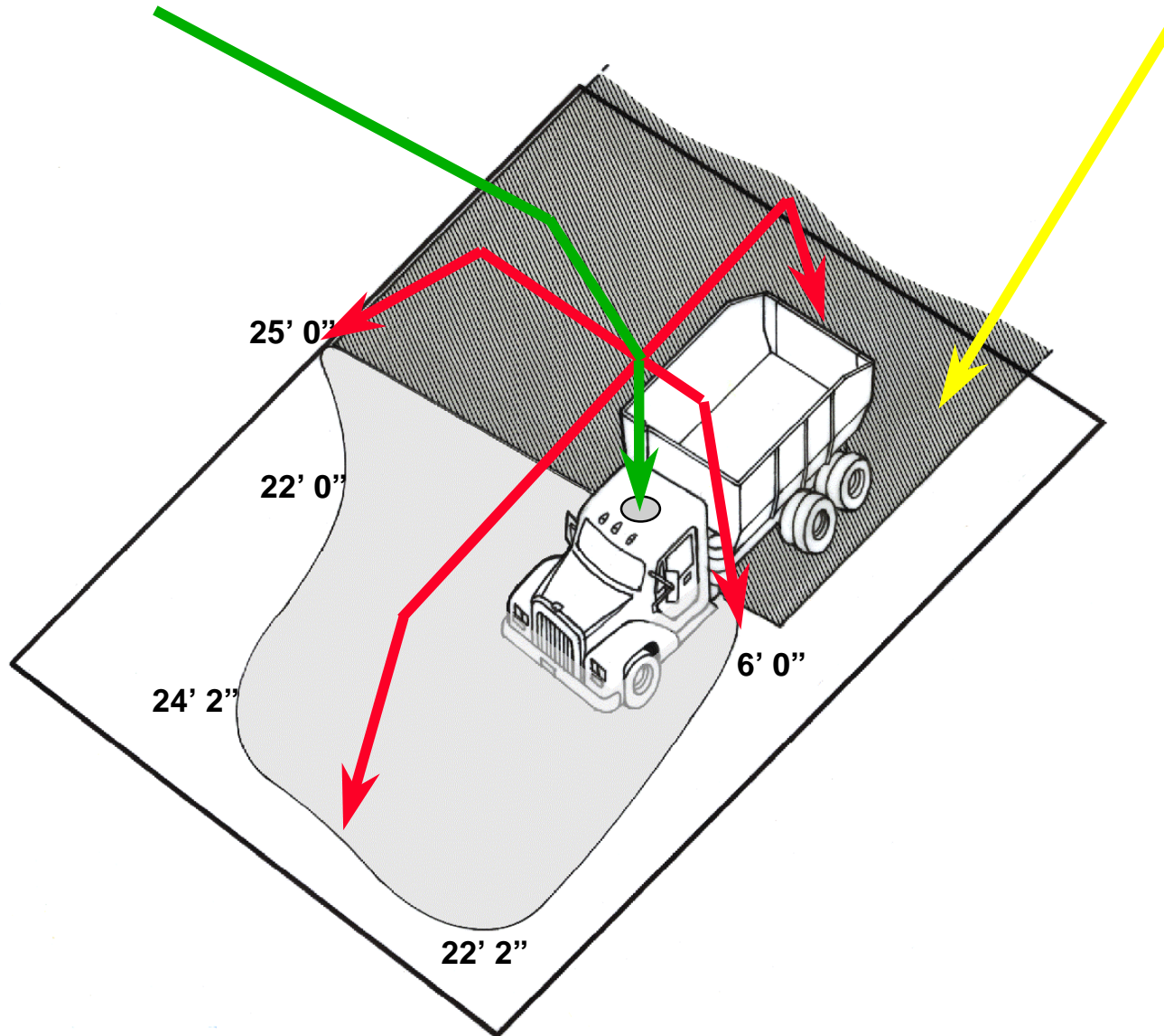

5 Ton Dump Truck

Eye level 7' 0" above ground level

This area is fully obstructed when the vehicle is full

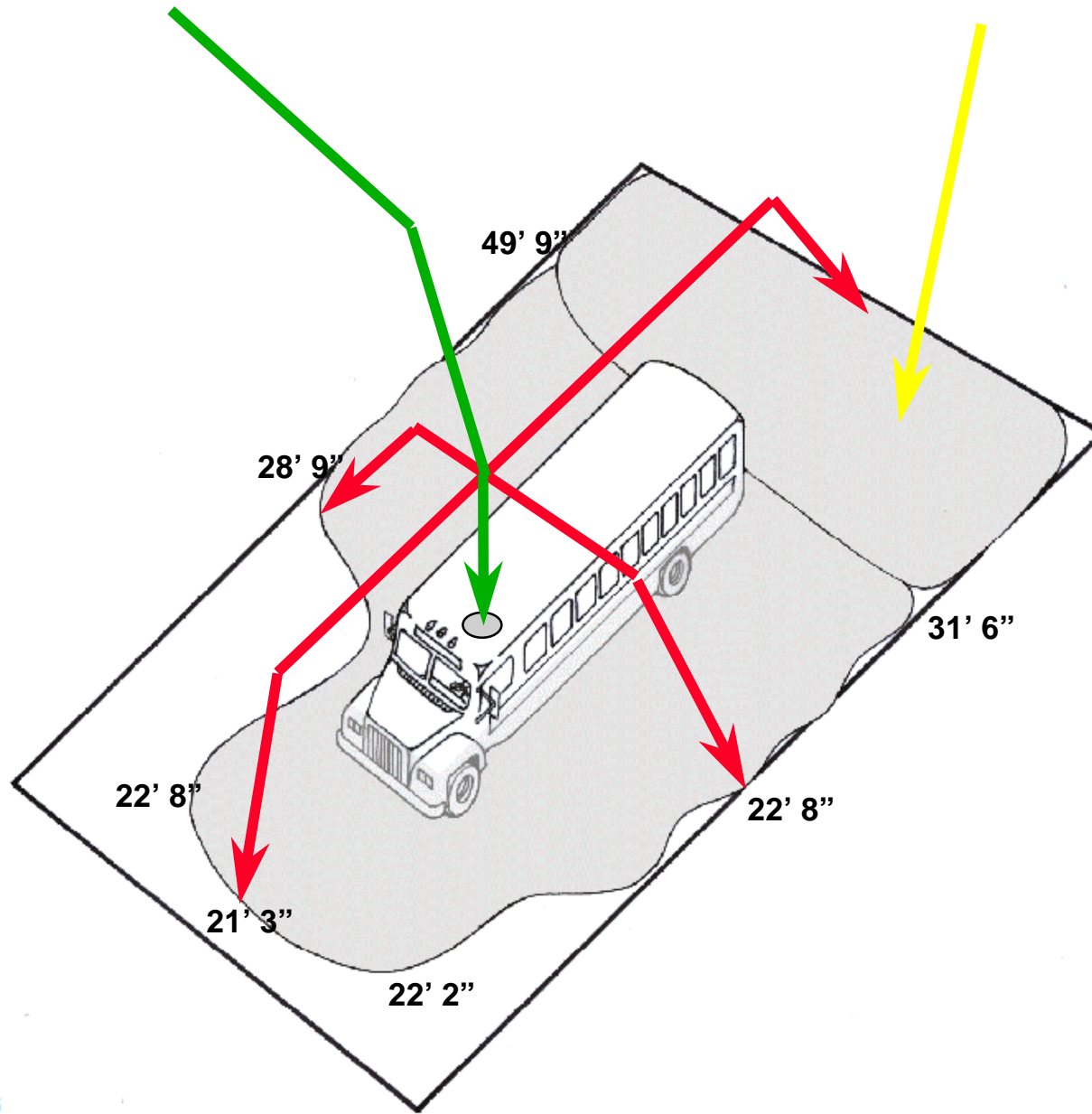

School Bus

Eye level 5' 11" above ground level

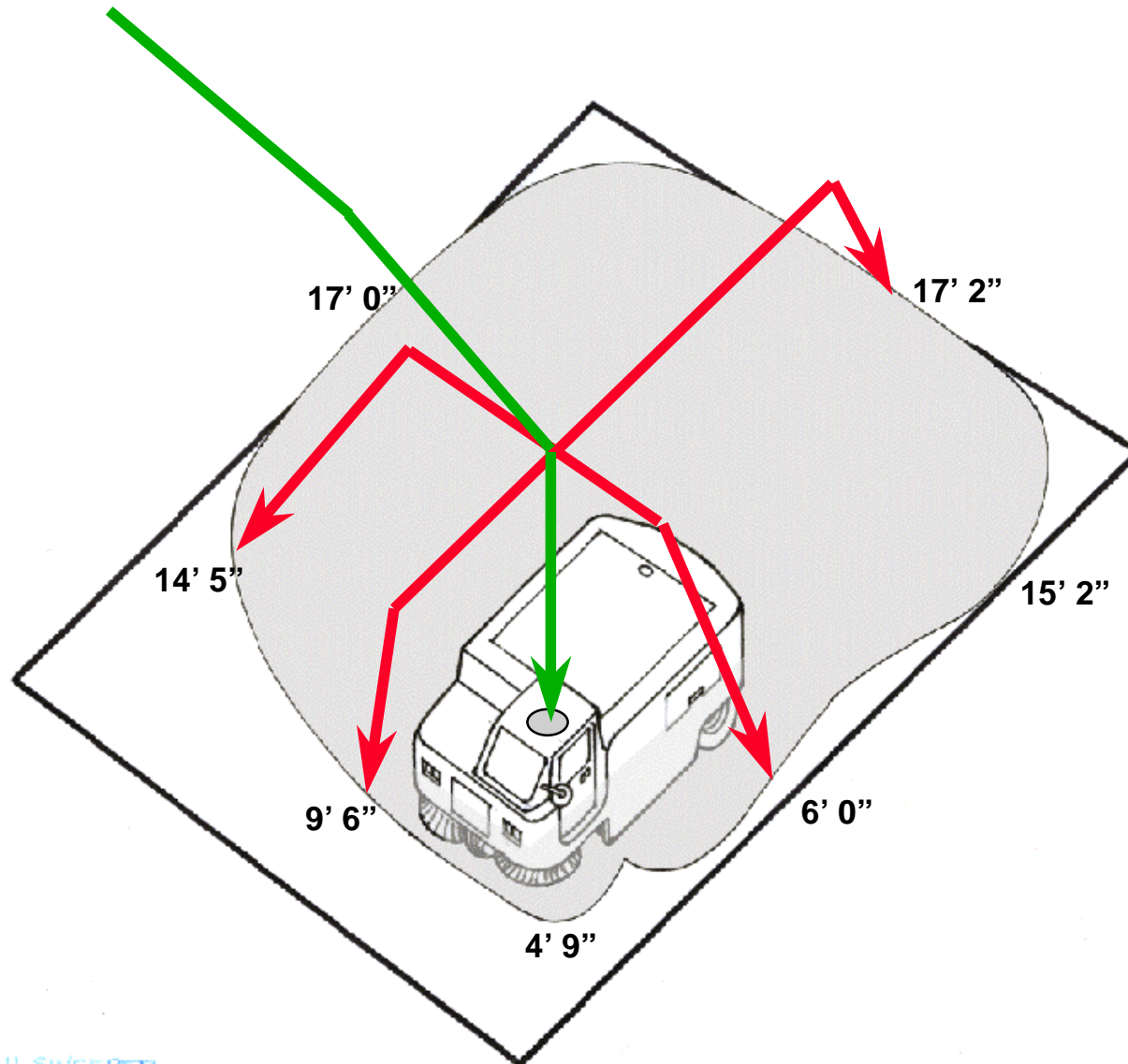

Street Sweeper

**Eye level 14' 8" above
ground level**

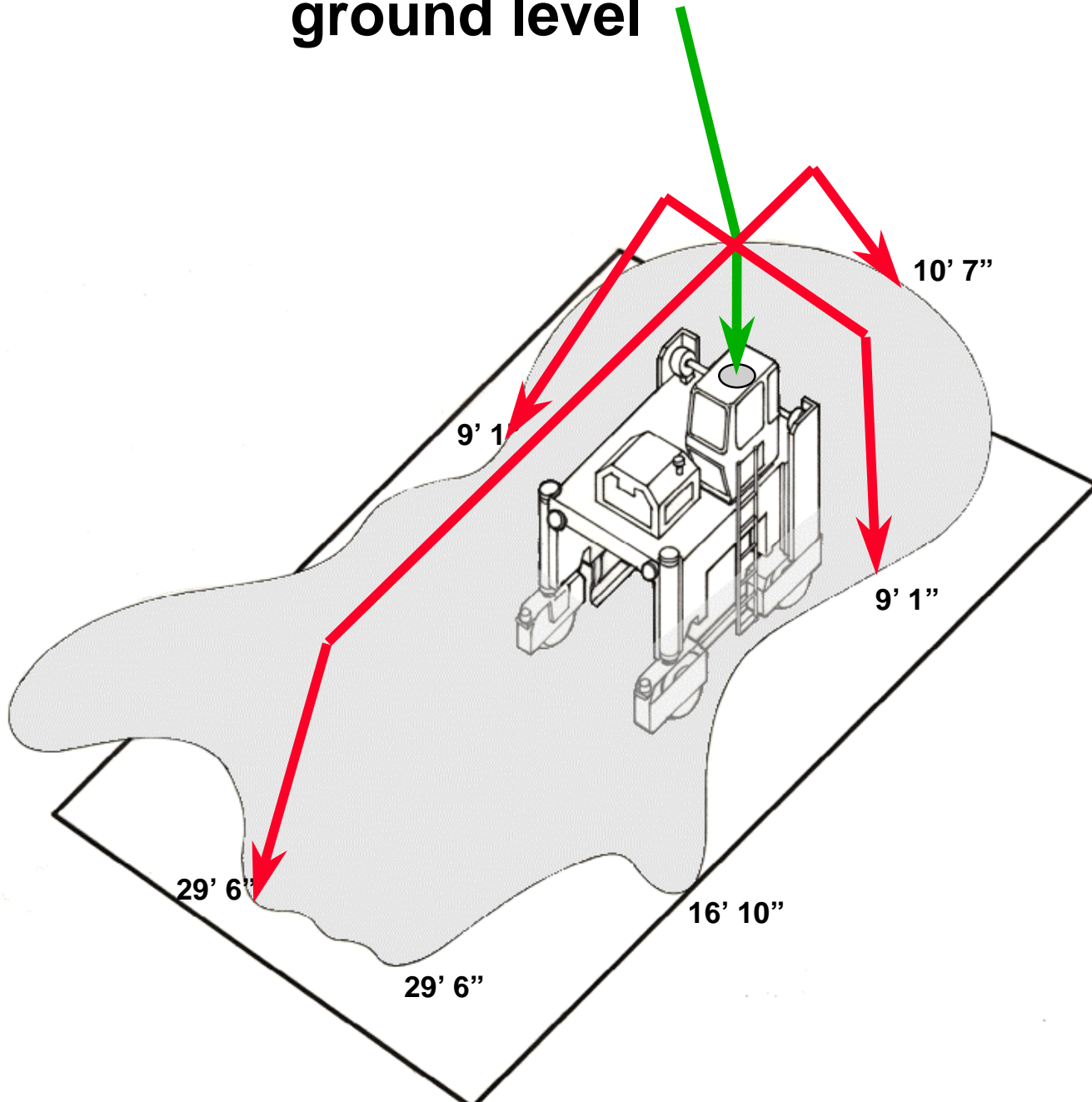

Straddle Lift Truck

Eye level 5' 1" above ground level

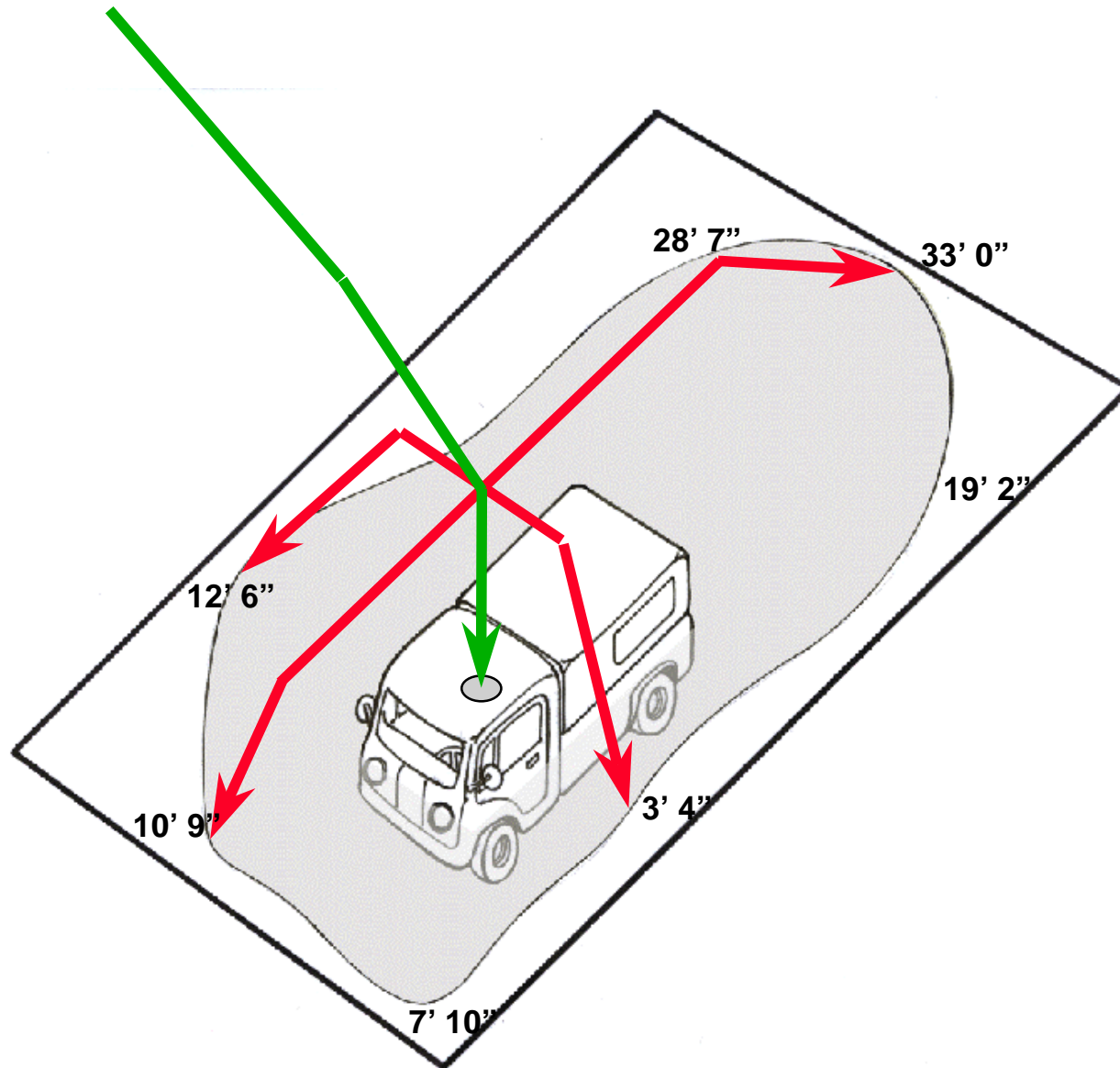

E-273 Cushman Scooter

**Eye level 9' 3" above
ground level**

**Area of fully
obstructed view**

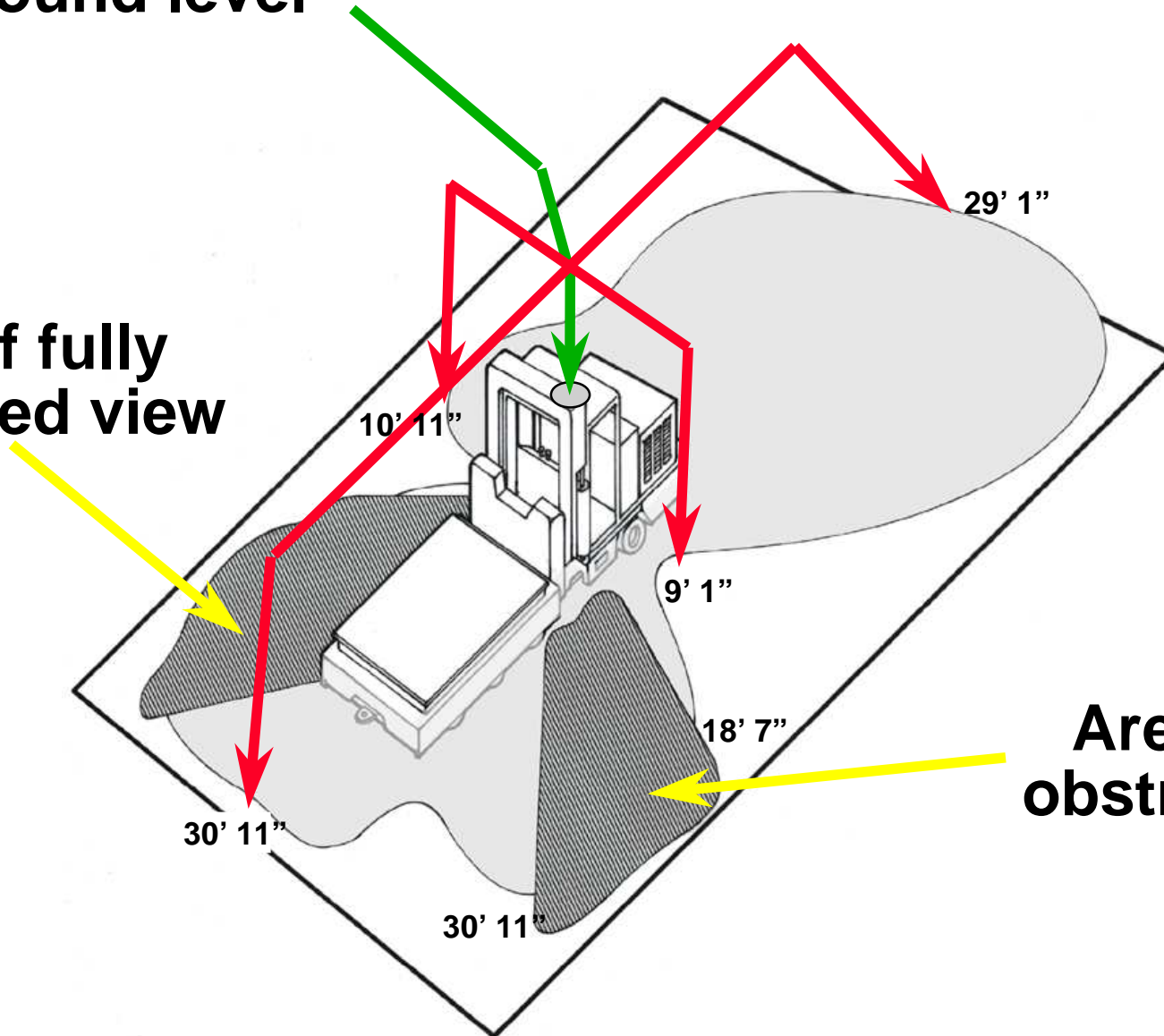

**Area of fully
obstructed view**

EL-PAR